

Technical Support Center: Optimizing Kinesore Concentration to Minimize Toxicity

Author: BenchChem Technical Support Team. **Date:** April 2026

Compound of Interest

Compound Name: *Kinesore*
Cat. No.: *B15604163*

[Get Quote](#)

This technical support center provides researchers, scientists, and drug development professionals with troubleshooting guides and frequently asked questions (FAQs) for optimizing **Kinesore** concentration in their experiments while minimizing potential toxicity.

Frequently Asked Questions (FAQs)

Q1: What is **Kinesore** and what is its mechanism of action?

A1: **Kinesore** is a cell-permeable small molecule that modulates the function of kinesin-1, a motor protein responsible for transporting cellular cargo along microtubules.^[1] It acts by inhibiting the interaction between the kinesin light chain 2 (KLC2) and a cargo adaptor protein called SKIP (SifA and kinesin-interacting protein).^{[2][3]} This inhibition paradoxically leads to the activation of kinesin-1's role in microtubule dynamics, causing a significant reorganization of the microtubule network within the cell.^{[2][4]}

Q2: What is the recommended working concentration for **Kinesore**?

A2: Based on published studies, the effective concentration of **Kinesore** in cell culture typically ranges from 25 μM to 50 μM .^{[2][3]} A concentration of 50 μM has been shown to produce a highly penetrant phenotype of microtubule network remodeling in cell lines such as HeLa.^{[2][3]}

However, the optimal concentration can be cell-type dependent, and it is always recommended to perform a dose-response experiment to determine the lowest effective concentration for your specific cell line and experimental endpoint.

Q3: Is **Kinesore** toxic to cells?

A3: The effects of **Kinesore** on the microtubule network have been observed to be reversible. For instance, a 2-hour washout of 50 μM **Kinesore** from HeLa cells treated for 1 hour led to the re-establishment of the normal radial microtubule array.[2] This reversibility suggests that **Kinesore** does not cause acute, irreversible toxicity at these concentrations and exposure times. However, comprehensive studies on the long-term effects and a full toxicological profile of **Kinesore** are not readily available. Therefore, it is crucial to assess the cytotoxicity of **Kinesore** in your specific experimental system.

Q4: How can I determine if **Kinesore** is toxic in my experiments?

A4: To assess the potential toxicity of **Kinesore**, it is recommended to perform cell viability and cytotoxicity assays. Commonly used assays include the MTT assay, which measures metabolic activity as an indicator of cell viability, and the LDH assay, which measures the release of lactate dehydrogenase from damaged cells as an indicator of cytotoxicity. Detailed protocols for these assays are provided in the "Experimental Protocols" section below.

Q5: What are the potential off-target effects of **Kinesore**?

A5: While **Kinesore** is designed to target the KLC2-SKIP interaction, like most small molecules, it may have off-target effects, especially at higher concentrations. Specific off-target effects of **Kinesore** have not been extensively characterized in publicly available literature. To minimize the risk of off-target effects, it is crucial to use the lowest effective concentration of **Kinesore** and include appropriate controls in your experiments.

Troubleshooting Guide

Issue	Possible Cause	Recommended Solution
High cell death observed after Kinesore treatment.	Kinesore concentration is too high for the specific cell line or experimental duration.	Perform a dose-response experiment to determine the IC50 value for cytotoxicity. Start with a broad range of concentrations (e.g., 1 μ M to 100 μ M) and narrow down to find the optimal concentration that balances efficacy and minimal toxicity. Reduce the incubation time with Kinesore.
Inconsistent or unexpected experimental results.	Potential off-target effects of Kinesore.	Use the lowest effective concentration of Kinesore as determined by your dose-response experiments. Include a negative control (vehicle, e.g., DMSO) and, if possible, a positive control for the expected phenotype. Consider using a structurally related but inactive compound as a negative control to rule out effects of the chemical scaffold.
No observable effect on the microtubule network.	Kinesore concentration is too low. The cell line is resistant to Kinesore's effects.	Increase the concentration of Kinesore. Ensure that the Kinesore stock solution is properly prepared and stored. Verify the expression of kinesin-1 (specifically KIF5B and KLC2) in your cell line, as the effect of Kinesore is dependent on the presence of this motor protein.[2]

Data Presentation

Currently, there is a lack of publicly available quantitative data on the dose-dependent cytotoxicity of **Kinesore** (e.g., IC50 values). Researchers are encouraged to generate this data for their specific cell lines using the protocols provided below. The following table is a template for how such data could be presented.

Table 1: Example of Dose-Dependent Cytotoxicity of **Kinesore** on a Hypothetical Cell Line

Kinesore Concentration (μM)	Cell Viability (%) (MTT Assay)	Cytotoxicity (%) (LDH Assay)
0 (Vehicle Control)	100	0
10	98 \pm 3.5	2 \pm 1.1
25	95 \pm 4.2	5 \pm 2.3
50	92 \pm 5.1	8 \pm 3.0
100	75 \pm 6.8	25 \pm 4.5
200	45 \pm 8.2	55 \pm 6.7

Data are presented as mean \pm standard deviation from three independent experiments.

Experimental Protocols

Protocol 1: MTT Assay for Cell Viability

This protocol is a standard method to assess cell viability by measuring the metabolic activity of cells.

Materials:

- Cells of interest
- **Kinesore**
- 96-well cell culture plates

- Complete cell culture medium
- MTT (3-(4,5-dimethylthiazol-2-yl)-2,5-diphenyltetrazolium bromide) solution (5 mg/mL in PBS)
- MTT solvent (e.g., acidified isopropanol or DMSO)
- Microplate reader

Procedure:

- Seed cells in a 96-well plate at a predetermined optimal density and allow them to adhere overnight.
- Prepare serial dilutions of **Kinesore** in complete cell culture medium.
- Remove the old medium from the wells and add 100 μ L of the **Kinesore** dilutions to the respective wells. Include vehicle-only wells as a negative control.
- Incubate the plate for the desired experimental duration (e.g., 24, 48, or 72 hours).
- Add 10 μ L of MTT solution to each well and incubate for 2-4 hours at 37°C, allowing for the formation of formazan crystals.
- Carefully remove the medium containing MTT.
- Add 100 μ L of MTT solvent to each well to dissolve the formazan crystals.
- Read the absorbance at 570 nm using a microplate reader.
- Calculate cell viability as a percentage of the vehicle-treated control cells.

Protocol 2: LDH Assay for Cytotoxicity

This protocol measures the release of lactate dehydrogenase (LDH) from damaged cells into the culture medium.

Materials:

- Cells of interest
- **Kinesore**
- 96-well cell culture plates
- Complete cell culture medium
- LDH cytotoxicity assay kit (commercially available)
- Microplate reader

Procedure:

- Seed cells in a 96-well plate and allow them to adhere overnight.
- Treat cells with serial dilutions of **Kinesore** as described in the MTT assay protocol. Include wells for spontaneous LDH release (vehicle control) and maximum LDH release (lysis buffer provided in the kit).
- Incubate the plate for the desired experimental duration.
- Following the manufacturer's instructions, transfer a portion of the cell culture supernatant to a new 96-well plate.
- Add the LDH reaction mixture to each well.
- Incubate for the recommended time at room temperature, protected from light.
- Add the stop solution provided in the kit.
- Measure the absorbance at the recommended wavelength (usually 490 nm).
- Calculate the percentage of cytotoxicity according to the kit's instructions, using the spontaneous and maximum release controls.

Mandatory Visualizations

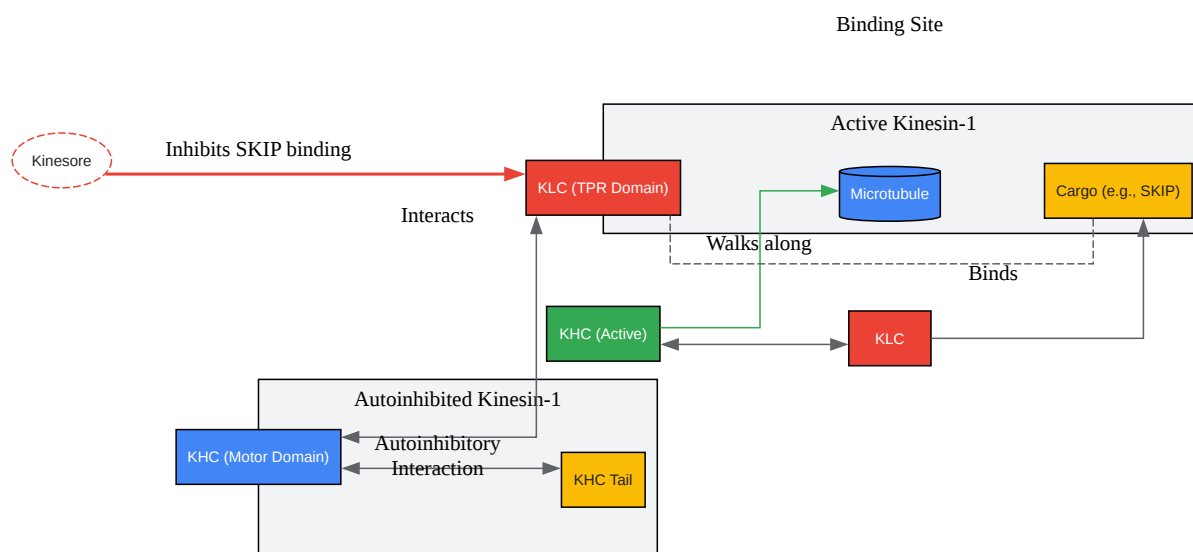

[Click to download full resolution via product page](#)

Caption: Kinesin-1 activation and the inhibitory action of **Kinesore**.

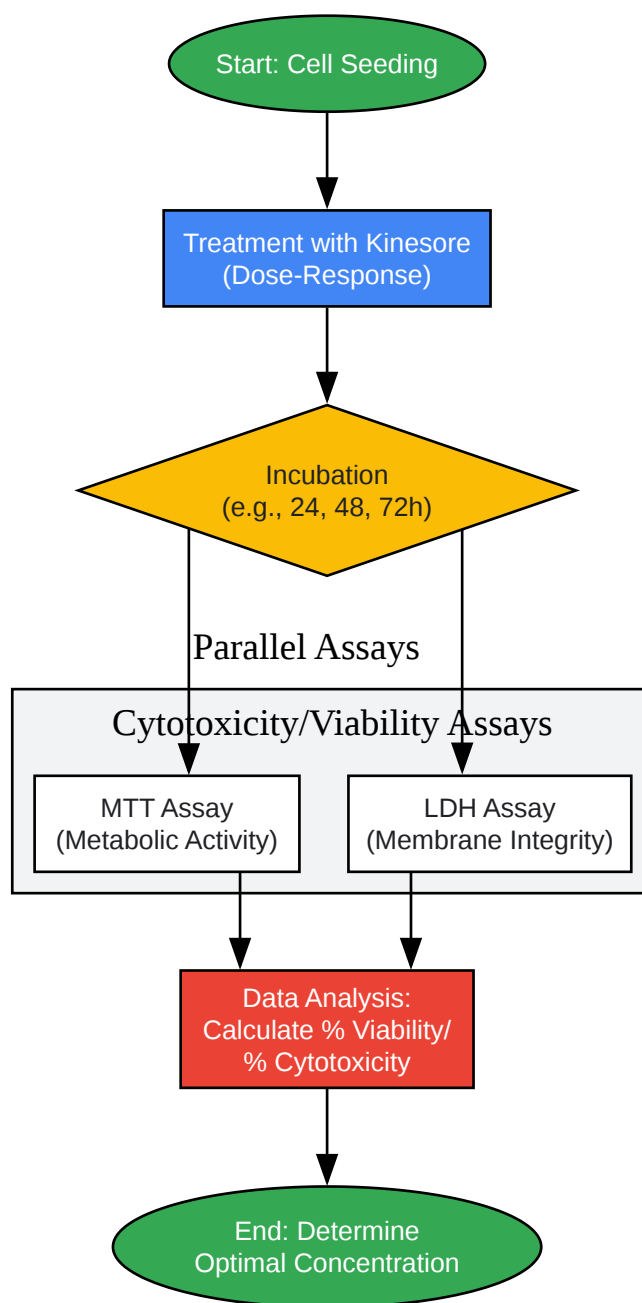

[Click to download full resolution via product page](#)

Caption: Workflow for assessing **Kinesore** toxicity.

Need Custom Synthesis?

BenchChem offers custom synthesis for rare earth carbides and specific isotopic labeling.

Email: info@benchchem.com or [Request Quote Online](#).

References

- [1. Structural basis for isoform-specific kinesin-1 recognition of Y-acidic cargo adaptors - PMC \[pmc.ncbi.nlm.nih.gov\]](#)
- [2. A small-molecule activator of kinesin-1 drives remodeling of the microtubule network - PMC \[pmc.ncbi.nlm.nih.gov\]](#)
- [3. medchemexpress.com \[medchemexpress.com\]](#)
- [4. A small-molecule activator of kinesin-1 drives remodeling of the microtubule network - PubMed \[pubmed.ncbi.nlm.nih.gov\]](#)
- To cite this document: BenchChem. [Technical Support Center: Optimizing Kinesore Concentration to Minimize Toxicity]. BenchChem, [2026]. [Online PDF]. Available at: [\[https://www.benchchem.com/product/b15604163/docs#technical-support-center-optimizing-kinesore-concentration-to-minimize-toxicity\]](https://www.benchchem.com/product/b15604163/docs#technical-support-center-optimizing-kinesore-concentration-to-minimize-toxicity)

Disclaimer & Data Validity:

The information provided in this document is for Research Use Only (RUO) and is strictly not intended for diagnostic or therapeutic procedures. While BenchChem strives to provide accurate protocols, we make no warranties, express or implied, regarding the fitness of this product for every specific experimental setup.

Technical Support: The protocols provided are for reference purposes. Unsure if this reagent suits your experiment?

Need Industrial/Bulk Grade? [Request Custom Synthesis Quote](#)

BenchChem

Our mission is to be the trusted global source of essential and advanced chemicals, empowering scientists and researchers to drive progress in science and industry.

Contact

Address: 3281 E Guasti Rd
Ontario, CA 91761, United States
Phone: (601) 213-4426
Email: info@benchchem.com

Contact our Ph.D. Support Team for a compatibility check