

# Technical Support Center: Negative Control Experiments for PIN1 Degradator-1 Studies

**Author:** BenchChem Technical Support Team. **Date:** April 2026

## Compound of Interest

Compound Name: *PIN1 degrader-1*

Cat. No.: *B15604780*

[Get Quote](#)

This technical support center provides troubleshooting guides and frequently asked questions (FAQs) for researchers working with **PIN1 degrader-1**. The information is tailored for scientists and drug development professionals to effectively design and troubleshoot negative control experiments.

## Frequently Asked Questions (FAQs)

Q1: Why are negative control experiments crucial for studies involving **PIN1 degrader-1**?

A1: Negative control experiments are essential to ensure that the observed degradation of the PIN1 protein is a direct result of the specific mechanism of the degrader and not due to off-target effects, general toxicity, or other experimental artifacts.<sup>[1]</sup> They provide a baseline for comparison and validate the specificity of the **PIN1 degrader-1**.

Q2: What are the different types of negative controls I should consider for my **PIN1 degrader-1** experiments?

A2: Several types of negative controls are recommended:

- Inactive Small Molecule Control: This is a molecule structurally similar to your active **PIN1 degrader-1** but is deficient in a key aspect of its mechanism.<sup>[2]</sup> This can be achieved by:
  - E3 Ligase Binding-Deficient Control: This control is modified to prevent it from binding to the E3 ligase. For CRBN-based degraders, this can be achieved by methylating the glutarimide nitrogen. For VHL-based degraders, inverting the stereochemistry of a critical chiral center on the E3 ligase ligand is a common strategy.<sup>[2][3]</sup>
  - Target Protein Binding-Deficient Control: This control is altered so that it no longer binds to PIN1. This is typically done by modifying the "warhead" portion of the degrader that interacts with PIN1.<sup>[2]</sup>
- Genetic Controls:
  - PIN1 Knockout (KO) Cells: Using CRISPR-Cas9 engineered cell lines that do not express PIN1 is a robust negative control.<sup>[4][5]</sup> The degrader should have no effect in these cells if its action is PIN1-dependent.
  - E3 Ligase Knockout (KO) Cells: Similarly, using cell lines where the specific E3 ligase recruited by the degrader (e.g., CRBN, VHL) is knocked out can confirm the dependency on that E3 ligase for degradation.<sup>[1]</sup>
- Vehicle Control: This is a control where cells are treated with the solvent (e.g., DMSO) used to dissolve the degrader at the same concentration as the experimental group. This accounts for any effects of the solvent itself.

Q3: My negative control compound, which shouldn't bind the E3 ligase, is still showing some PIN1 degradation. What could be the reason?

A3: This could be due to several factors:

- Off-Target Effects: The negative control compound, despite its modification, might have unexpected off-target activities that lead to PIN1 degradation through a different pathway.
- Compound Instability: The compound might be unstable in the cell culture media and break down into components that have an effect on PIN1 levels.

- Experimental Artifacts: Ensure there are no issues with sample handling, loading in western blots, or other technical aspects of the experiment.

Q4: How do I interpret the results from my PIN1 knockout (KO) cell line experiment?

A4: In a PIN1 KO cell line, treatment with **PIN1 degrader-1** should not result in a further decrease in PIN1 levels (as it's already absent). Furthermore, any downstream signaling effects observed with the degrader in wild-type cells (e.g., changes in Cyclin D1 or c-Myc levels) should be absent in the PIN1 KO cells.<sup>[6][7]</sup> This confirms that the observed cellular phenotype is a direct consequence of PIN1 degradation.

## Troubleshooting Guides

### Western Blot Troubleshooting for PIN1 Degradation

Problem	Possible Cause	Recommended Solution
No PIN1 band in wild-type untreated control	- Antibody issue (inactive, wrong antibody).- Low PIN1 expression in the cell line.	- Use a new, validated PIN1 antibody.- Confirm antibody specificity with a positive control (e.g., recombinant PIN1 protein or a known PIN1-expressing cell lysate).- Increase the amount of protein loaded on the gel.[8]
Weak PIN1 signal in controls	- Insufficient protein loaded.- Inefficient protein transfer.- Primary antibody concentration too low.	- Perform a protein concentration assay (e.g., BCA) and load at least 20-30 µg of total protein.- Check transfer efficiency with Ponceau S staining.- Optimize the primary antibody concentration and increase incubation time (e.g., overnight at 4°C).[9]
Multiple bands in the PIN1 lane	- Non-specific antibody binding.- Protein degradation during sample preparation.- Post-translational modifications of PIN1.	- Increase the stringency of washes.- Use a fresh lysis buffer with protease inhibitors and keep samples on ice.- Consult literature for known PIN1 isoforms or modifications in your cell line.[10][11]
Inconsistent loading control (e.g., GAPDH, β-actin) bands	- Pipetting errors.- Uneven protein transfer.	- Carefully perform protein quantification and ensure equal loading volumes.- Ensure the transfer sandwich is assembled correctly without air bubbles.[12]

## Troubleshooting PIN1 Degradator-1 Activity

Problem	Possible Cause	Recommended Solution
No degradation of PIN1 with the active degrader	- Degrader is inactive or degraded.- Incorrect degrader concentration.- Insufficient treatment time.	- Verify the integrity and concentration of the degrader stock solution.- Perform a dose-response experiment with a wider range of concentrations.- Conduct a time-course experiment (e.g., 4, 8, 16, 24 hours) to determine the optimal treatment duration.[6]
"Hook effect" observed (less degradation at higher concentrations)	- At high concentrations, the formation of binary complexes (Degrader-PIN1 or Degrader-E3 ligase) is favored over the productive ternary complex (PIN1-Degrader-E3 ligase).[13]	- Perform a full dose-response curve to identify the optimal concentration range for degradation and avoid using concentrations that are too high.
High cell death in all treatment groups, including controls	- Compound toxicity unrelated to PIN1 degradation.- High concentration of vehicle (e.g., DMSO).	- Perform a cell viability assay (e.g., MTT or CellTiter-Glo) to assess the general cytotoxicity of your compounds.- Ensure the final DMSO concentration is non-toxic (typically $\leq 0.5\%$ ).

## Quantitative Data Summary

The following tables summarize hypothetical quantitative data from typical negative control experiments for a PIN1 degrader.

Table 1: PIN1 Degradation in Wild-Type vs. PIN1 KO Cells

Treatment (24h)	Cell Line	PIN1 Protein Level (% of Vehicle Control)
Vehicle (DMSO)	Wild-Type	100%
PIN1 Degradar-1 (1 $\mu$ M)	Wild-Type	15%
Inactive Control (1 $\mu$ M)	Wild-Type	98%
Vehicle (DMSO)	PIN1 KO	Not Detectable
PIN1 Degradar-1 (1 $\mu$ M)	PIN1 KO	Not Detectable

Table 2: Dose-Response of **PIN1 Degradar-1** and Inactive Control

Compound	Concentration	% PIN1 Degradation (Dmax)	DC50
PIN1 Degradar-1	0.01 - 10 $\mu$ M	~95%	177 nM[6]
Inactive Control	0.01 - 10 $\mu$ M	< 5%	> 10 $\mu$ M

Table 3: Effect on Downstream Target Proteins

Treatment (24h, 1 $\mu$ M)	% Change in Cyclin D1 Protein Level	% Change in c-Myc Protein Level
Vehicle (DMSO)	0%	0%
PIN1 Degradar-1	-70%	-65%
Inactive Control	-3%	-5%
PIN1 Degradar-1 in PIN1 KO cells	+2%	-1%

## Key Experimental Protocols

### Protocol 1: Western Blotting for PIN1 Degradation

- **Cell Culture and Treatment:** Plate cells at an appropriate density. The following day, treat with **PIN1 degrader-1**, inactive control, or vehicle (DMSO) at the desired concentrations for the specified time (e.g., 24 hours).
- **Cell Lysis:** Wash cells with ice-cold PBS. Lyse cells in RIPA buffer supplemented with protease and phosphatase inhibitors.[\[12\]](#)
- **Protein Quantification:** Determine the protein concentration of each lysate using a BCA assay.
- **Sample Preparation:** Normalize protein concentrations and add Laemmli sample buffer. Boil samples at 95°C for 5-10 minutes.
- **SDS-PAGE and Transfer:** Load equal amounts of protein onto an SDS-PAGE gel. Transfer the separated proteins to a PVDF or nitrocellulose membrane.
- **Blocking:** Block the membrane with 5% non-fat milk or BSA in TBST for 1 hour at room temperature.
- **Primary Antibody Incubation:** Incubate the membrane with a primary antibody specific for PIN1 (and a loading control like GAPDH or  $\beta$ -actin) overnight at 4°C.
- **Secondary Antibody Incubation:** Wash the membrane and incubate with an HRP-conjugated secondary antibody for 1 hour at room temperature.
- **Detection:** Add a chemiluminescent substrate and visualize the bands using an imaging system.
- **Quantification:** Quantify the band intensities using software like ImageJ. Normalize the PIN1 band intensity to the loading control.

## Protocol 2: Cell Viability Assay (MTT Assay)

- **Cell Seeding:** Seed cells in a 96-well plate and allow them to attach overnight.
- **Compound Treatment:** Treat cells with a serial dilution of **PIN1 degrader-1** and the inactive control for the desired duration (e.g., 72 hours).

- **MTT Addition:** Add MTT reagent to each well and incubate for 2-4 hours at 37°C, allowing viable cells to convert MTT to formazan crystals.
- **Solubilization:** Add a solubilization solution (e.g., DMSO or a specialized buffer) to dissolve the formazan crystals.
- **Absorbance Reading:** Read the absorbance at the appropriate wavelength (e.g., 570 nm) using a plate reader.
- **Data Analysis:** Calculate the percentage of cell viability relative to the vehicle-treated control cells.

## Protocol 3: Co-Immunoprecipitation (Co-IP) to Confirm Loss of Interaction

- **Cell Lysis:** Lyse cells treated with either vehicle or **PIN1 degrader-1** using a non-denaturing Co-IP lysis buffer.
- **Pre-clearing (Optional):** Incubate the lysate with protein A/G beads to reduce non-specific binding.<sup>[14]</sup>
- **Immunoprecipitation:** Incubate the pre-cleared lysate with an antibody against a known PIN1 interactor (e.g., a substrate) overnight at 4°C.
- **Complex Capture:** Add protein A/G beads to pull down the antibody-protein complexes.
- **Washing:** Wash the beads several times with Co-IP wash buffer to remove non-specifically bound proteins.
- **Elution:** Elute the protein complexes from the beads using a low-pH elution buffer or by boiling in SDS-PAGE sample buffer.
- **Western Blot Analysis:** Analyze the eluted samples by Western blotting using an antibody against PIN1 to see if it co-precipitated. In the degrader-treated sample, the PIN1 band should be significantly reduced or absent.

## Visualizations

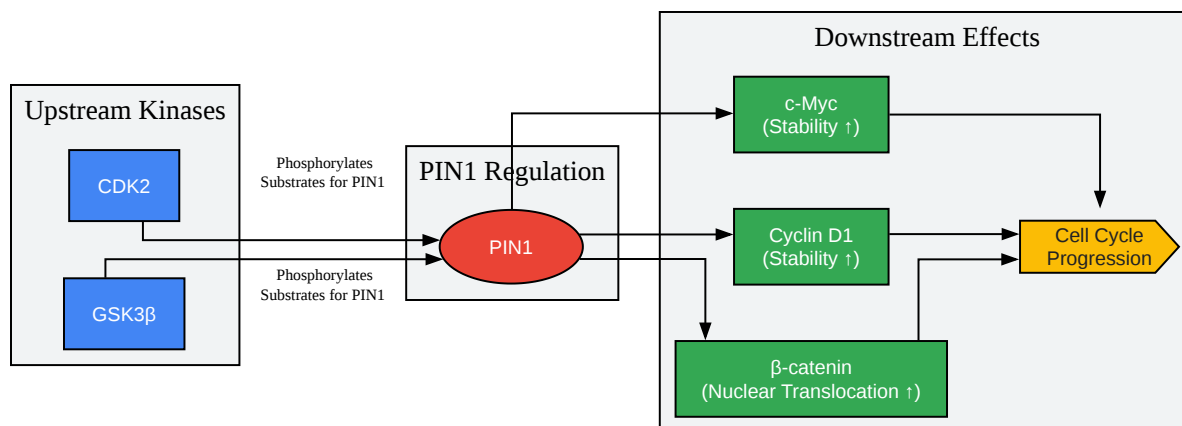

[Click to download full resolution via product page](#)

Caption: Simplified PIN1 signaling pathway showing upstream kinases and downstream effects.

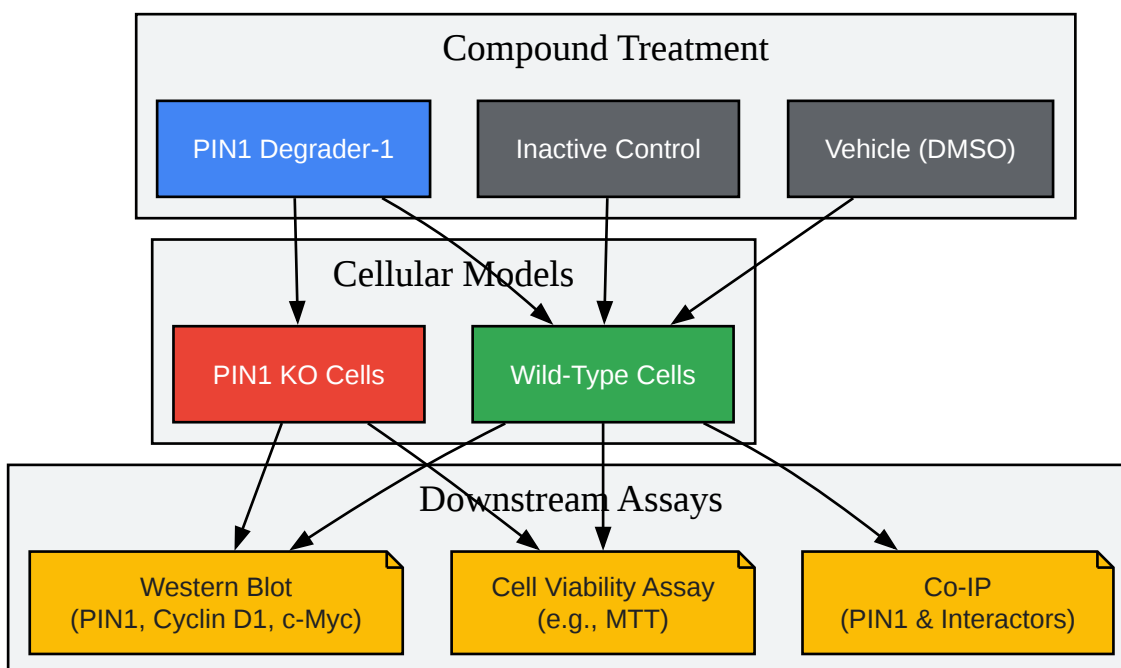

[Click to download full resolution via product page](#)

Caption: Experimental workflow for testing **PIN1 degrader-1** with negative controls.

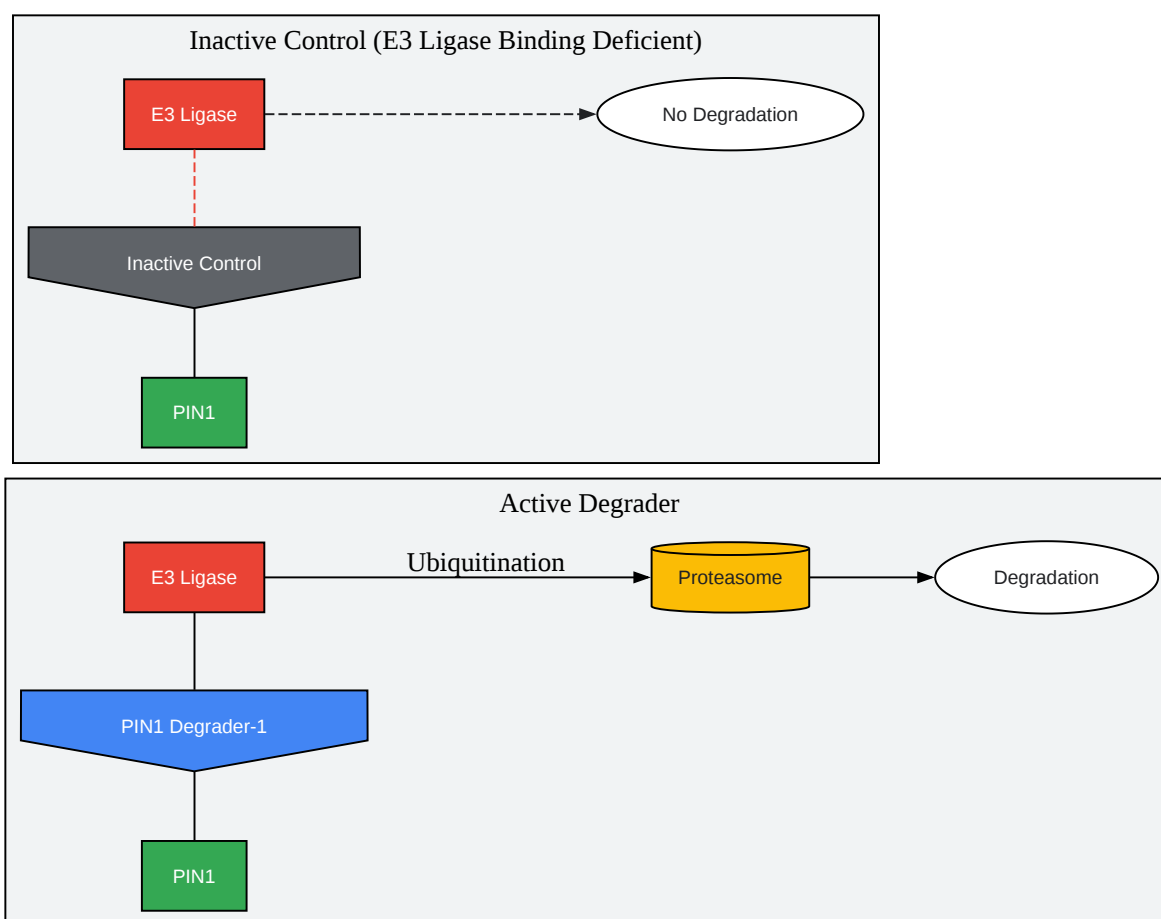

[Click to download full resolution via product page](#)

Caption: Logical relationship between an active degrader and an inactive control.

### Need Custom Synthesis?

BenchChem offers custom synthesis for rare earth carbides and specific isotopic labeling.

Email: [info@benchchem.com](mailto:info@benchchem.com) or [Request Quote Online](#).

## References

- [1. creative-diagnostics.com \[creative-diagnostics.com\]](#)
- [2. Discovery of potent PROTAC degraders of Pin1 for the treatment of acute myeloid leukemia - Chemical Science \(RSC Publishing\) \[pubs.rsc.org\]](#)
- [3. Western Blotting Troubleshooting Guide | Cell Signaling Technology \[cellsignal.com\]](#)
- [4. cyagen.com \[cyagen.com\]](#)
- [5. Overcoming the pitfalls of validating knockout cell lines by western blot \[horizondiscovery.com\]](#)
- [6. Discovery of potent PROTAC degraders of Pin1 for the treatment of acute myeloid leukemia - PMC \[pmc.ncbi.nlm.nih.gov\]](#)
- [7. researchgate.net \[researchgate.net\]](#)
- [8. biorxiv.org \[biorxiv.org\]](#)
- [9. Identification of a potent and selective covalent Pin1 inhibitor - PMC \[pmc.ncbi.nlm.nih.gov\]](#)
- [10. cytivalifesciences.com \[cytivalifesciences.com\]](#)
- [11. Immunoblot screening of CRISPR/Cas9-mediated gene knockouts without selection - PMC \[pmc.ncbi.nlm.nih.gov\]](#)
- [12. bio-rad.com \[bio-rad.com\]](#)
- [13. benchchem.com \[benchchem.com\]](#)
- [14. bitesizebio.com \[bitesizebio.com\]](#)
- [To cite this document: BenchChem. \[Technical Support Center: Negative Control Experiments for PIN1 Degradation-1 Studies\]. BenchChem, \[2026\]. \[Online PDF\]. Available at: \[https://www.benchchem.com/product/b15604780/docs#technical-support-center-negative-control-experiments-for-pin1-degrader-1-studies\]](#)

---

### Disclaimer & Data Validity:

The information provided in this document is for Research Use Only (RUO) and is strictly not intended for diagnostic or therapeutic procedures. While BenchChem strives to provide accurate protocols, we make no warranties, express or implied, regarding the fitness of this product for every specific experimental setup.

**Technical Support:** The protocols provided are for reference purposes. Unsure if this reagent suits your experiment?

**Need Industrial/Bulk Grade?** [Request Custom Synthesis Quote](#)

## BenchChem

Our mission is to be the trusted global source of essential and advanced chemicals, empowering scientists and researchers to drive progress in science and industry.

### Contact

Address: 3281 E Guasti Rd  
Ontario, CA 91761, United States  
Phone: (601) 213-4426  
Email: [info@benchchem.com](mailto:info@benchchem.com)

[Contact our Ph.D. Support Team for a compatibility check](#)