

In Vivo Therapeutic Potential of PMX-53: A Comparative Analysis

Author: BenchChem Technical Support Team. **Date:** April 2026

Compound of Interest

Compound Name: Pmx-53
CAS No.: 219639-75-5
Cat. No.: B15604090

[Get Quote](#)

For Researchers, Scientists, and Drug Development Professionals

This guide provides an objective comparison of the in vivo performance of **PMX-53**, a potent C5a receptor 1 (C5aR1) antagonist, with alternative therapies. The information presented is supported by experimental data to assist in the evaluation of its therapeutic potential.

Executive Summary

PMX-53 is a cyclic hexapeptide that acts as a potent antagonist of the C5a receptor 1 (C5aR1), also known as CD88.[1][2][3] This receptor is a key component of the complement system, a part of the innate immune system that plays a crucial role in inflammatory responses.[1][2][4] The interaction of the anaphylatoxin C5a with C5aR1 on immune cells like neutrophils and macrophages triggers a cascade of inflammatory events.[1][2] By blocking this interaction, **PMX-53** has demonstrated therapeutic potential in a variety of preclinical models of inflammatory diseases, including sepsis, inflammatory bowel disease, and neurodegenerative conditions.[1] This guide focuses on the in vivo validation of **PMX-53**, comparing its efficacy and pharmacokinetic profile with other C5aR1 antagonists, namely JPE-1375 and PMX205.

Comparative Performance of C5aR1 Antagonists

The following tables summarize the key in vivo and in vitro performance metrics of **PMX-53** in comparison to JPE-1375, a linear peptidomimetic C5aR1 antagonist, and PMX205, a lipophilic analogue of **PMX-53**.^{[5][6]}

In Vivo Efficacy and Duration of Action

Parameter	PMX-53	JPE-1375	Reference
Minimally Effective Dose (i.v.)	1 mg/kg	1 mg/kg	[5][7]
In Vivo Active Duration	Up to 6 hours	< 2 hours	[5][7]
Effect on C5a-induced PMN Mobilization	Significant inhibition at 0.25, 2, and 6 hours	Significant inhibition only at 0.25 hours	[5]
Effect on C5a-induced TNF- α Levels	~90% decrease at 0.25, 2, and 6 hours	~90% decrease only at 0.25 hours	[5]

Pharmacokinetic Profiles

Parameter	PMX-53	PMX205	Reference
Half-life (i.v.)	~20 minutes	~20 minutes	[2][6]
Oral Bioavailability	9%	23%	[2][6]
CNS Penetration	Less efficient	More efficient	[2][6]
Primary Route of Elimination	Urinary excretion	Urinary excretion	[2][6]

In Vitro Potency

Parameter	PMX-53	Reference
IC50 (Neutrophil Myeloperoxidase Release)	22 nM	[1][2][3]
IC50 (Neutrophil Chemotaxis)	75 nM	[1][2][3]

Signaling Pathway and Experimental Workflow

To understand the mechanism of action and the experimental validation of **PMX-53**, the following diagrams illustrate the C5a-C5aR1 signaling pathway and the workflow of a key in vivo experiment.

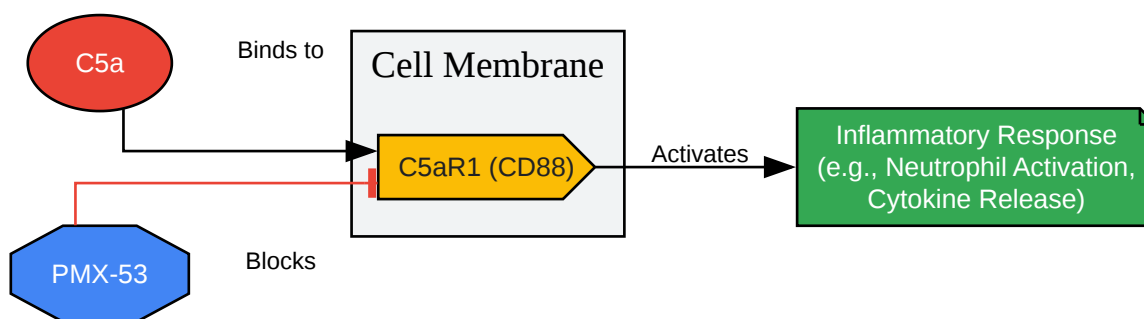

[Click to download full resolution via product page](#)

Caption: C5a-C5aR1 signaling pathway and **PMX-53**'s mechanism of action.

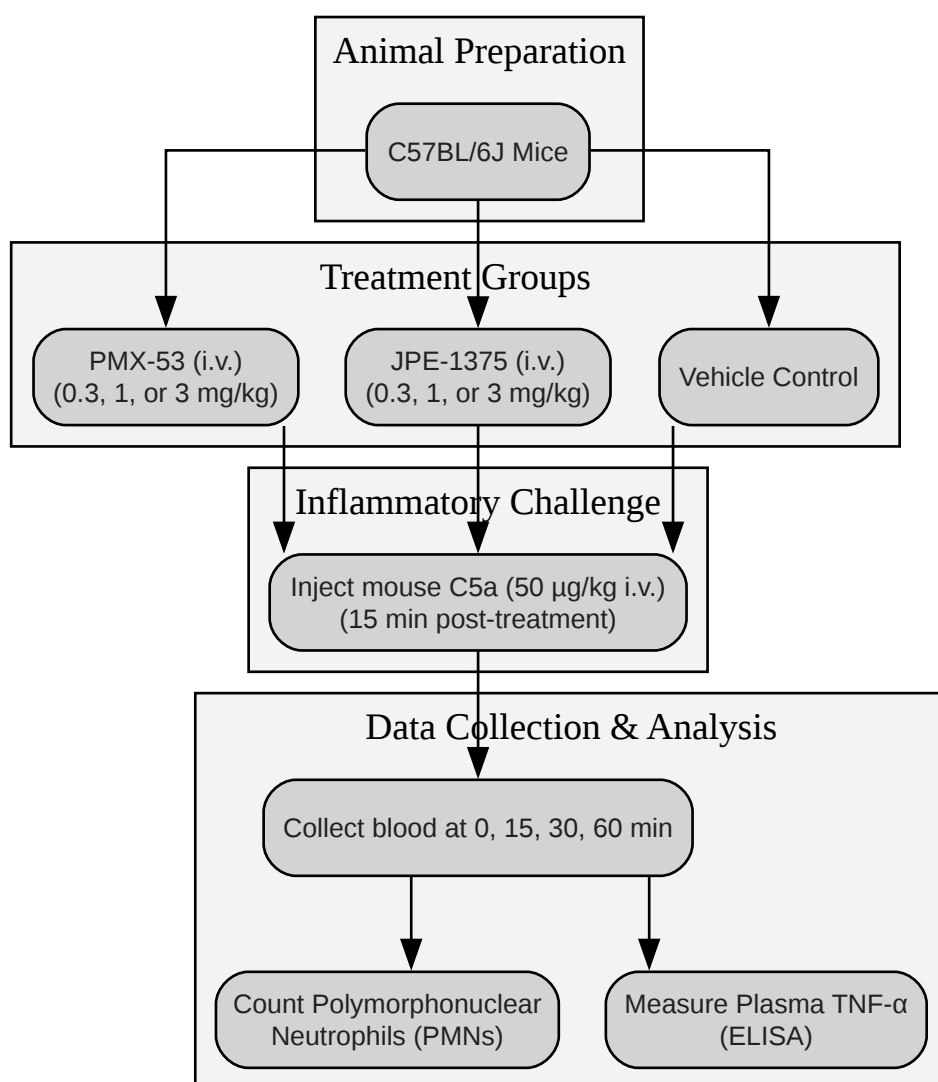

[Click to download full resolution via product page](#)

Caption: In vivo pharmacodynamic experimental workflow.

Experimental Protocols

Detailed methodologies for the key experiments cited in this guide are provided below.

In Vivo C5a-Induced Pharmacodynamic Model

This model was utilized to compare the in vivo efficacy and duration of action of **PMX-53** and JPE-1375.[5][7]

Animals:

- Male C57BL/6J mice were used for the study.[5][7]

Reagents:

- Recombinant mouse C5a (Sino Biological, China).[5]
- **PMX-53** and JPE-1375 were dissolved in a suitable vehicle for intravenous (i.v.) injection.

Procedure for Dose-Response Study:

- Mice were administered with **PMX-53** or JPE-1375 via i.v. injection at doses of 0.3, 1.0, and 3.0 mg/kg.[5]
- Fifteen minutes following the antagonist administration, recombinant mouse C5a was injected i.v. at a dose of 50 µg/kg.[5]
- Blood samples were collected from the tail tip at 0, 15, 30, and 60 minutes after C5a injection to perform blood smears for polymorphonuclear neutrophil (PMN) mobilization analysis.[7]
- At 60 minutes, plasma was collected to measure TNF-α levels.[7]

Procedure for Time-Profile Study:

- A single dose of 1 mg/kg of **PMX-53** or JPE-1375 was administered i.v. at different time points (15 minutes, 2 hours, 6 hours, and 24 hours) before the i.v. injection of C5a (50 µg/kg).[5][7]
- Blood and plasma samples were collected and analyzed for PMN mobilization and TNF-α levels as described above.[7]

Measurement of Plasma TNF-α

Plasma TNF-α levels were quantified using a commercial mouse TNF-α ELISA kit.

General ELISA Protocol:

- All reagents, samples, and standards are brought to room temperature before use.
- Standard dilutions are prepared to generate a standard curve.

- Samples and standards are added to the wells of an ELISA plate pre-coated with an anti-mouse TNF- α antibody.
- The plate is incubated to allow the TNF- α in the samples to bind to the immobilized antibody.
- After washing, a biotinylated detection antibody specific for mouse TNF- α is added to the wells.
- Following another incubation and wash step, streptavidin-horseradish peroxidase (SA-HRP) is added, which binds to the biotinylated detection antibody.
- A chromogenic substrate (e.g., TMB) is added, and the color development is proportional to the amount of TNF- α in the sample.
- The reaction is stopped, and the absorbance is read on a plate reader. The concentration of TNF- α in the samples is determined by interpolating from the standard curve.[8][9]

Conclusion

The in vivo data strongly support the therapeutic potential of **PMX-53** as a C5aR1 antagonist. While having a similar minimally effective dose to the linear peptide JPE-1375, **PMX-53** demonstrates a significantly longer duration of action in a mouse pharmacodynamic model.[5][7] This prolonged efficacy is a key advantage for potential therapeutic applications. In comparison to its analogue PMX205, **PMX-53** has lower oral bioavailability and CNS penetration, suggesting that the choice between these two compounds may depend on the desired route of administration and the therapeutic target.[2][6] The detailed experimental protocols provided herein offer a basis for the replication and further investigation of **PMX-53**'s in vivo effects. These findings underscore the potential of **PMX-53** as a valuable candidate for the development of treatments for a range of inflammatory diseases.

Need Custom Synthesis?

BenchChem offers custom synthesis for rare earth carbides and specific isotopic labeling.

Email: info@benchchem.com or [Request Quote Online](#).

References

- [1. medchemexpress.com \[medchemexpress.com\]](https://www.medchemexpress.com)
- [2. Preclinical Pharmacokinetics of Complement C5a Receptor Antagonists PMX53 and PMX205 in Mice - PMC \[pmc.ncbi.nlm.nih.gov\]](https://pubmed.ncbi.nlm.nih.gov/31111111/)
- [3. researchgate.net \[researchgate.net\]](https://www.researchgate.net)
- [4. Pharmacological inhibition of complement C5a-C5a1 receptor signalling ameliorates disease pathology in the hSOD1G93A mouse model of amyotrophic lateral sclerosis - PMC \[pmc.ncbi.nlm.nih.gov\]](https://pubmed.ncbi.nlm.nih.gov/31111111/)
- [5. pubs.acs.org \[pubs.acs.org\]](https://pubs.acs.org)
- [6. In Vivo Pharmacodynamic Method to Assess Complement C5a Receptor Antagonist Efficacy - PubMed \[pubmed.ncbi.nlm.nih.gov\]](https://pubmed.ncbi.nlm.nih.gov/31111111/)
- [7. In Vivo Pharmacodynamic Method to Assess Complement C5a Receptor Antagonist Efficacy - PMC \[pmc.ncbi.nlm.nih.gov\]](https://pubmed.ncbi.nlm.nih.gov/31111111/)
- [8. cdn.stemcell.com \[cdn.stemcell.com\]](https://www.cdn.stemcell.com)
- [9. biosensis.com \[biosensis.com\]](https://www.biosensis.com)
- To cite this document: BenchChem. [In Vivo Therapeutic Potential of PMX-53: A Comparative Analysis]. BenchChem, [2026]. [Online PDF]. Available at: [\[https://www.benchchem.com/product/b15604090/docs#in-vivo-therapeutic-potential-of-pmx-53-a-comparative-analysis\]](https://www.benchchem.com/product/b15604090/docs#in-vivo-therapeutic-potential-of-pmx-53-a-comparative-analysis)

Disclaimer & Data Validity:

The information provided in this document is for Research Use Only (RUO) and is strictly not intended for diagnostic or therapeutic procedures. While BenchChem strives to provide accurate protocols, we make no warranties, express or implied, regarding the fitness of this product for every specific experimental setup.

Technical Support: The protocols provided are for reference purposes. Unsure if this reagent suits your experiment?

Need Industrial/Bulk Grade? [Request Custom Synthesis Quote](#)

BenchChem

Our mission is to be the trusted global source of essential and advanced chemicals, empowering scientists and researchers to drive progress in science and industry.

Contact

Address: 3281 E Guasti Rd

Ontario, CA 91761, United States

Phone: (601) 213-4426

Email: info@benchchem.com

[Contact our Ph.D. Support Team for a compatibility check](#)