

Confirming LYN-1604 Target Engagement in Cells: A Comparative Guide

Author: BenchChem Technical Support Team. **Date:** April 2026

Compound of Interest

Compound Name: LYN-1604

Cat. No.: B15604115

[Get Quote](#)

For Researchers, Scientists, and Drug Development Professionals

This guide provides a comprehensive overview and comparison of experimental methods to confirm the target engagement of **LYN-1604**, a known activator of Unc-51 like autophagy activating kinase 1 (ULK1), within a cellular context.^{[1][2][3][4]} Establishing that a compound directly interacts with its intended target in living cells is a critical step in drug discovery, validating its mechanism of action and ensuring that observed phenotypic effects are on-target. This document details various approaches, from direct biophysical measurements to assessments of downstream signaling, and includes detailed experimental protocols and comparative data to aid in the selection of the most appropriate method for your research needs.

Introduction to LYN-1604 and its Target, ULK1

LYN-1604 is a small molecule agonist of ULK1, a serine/threonine kinase that plays a pivotal role in initiating the autophagy pathway.^{[2][3]} Autophagy is a fundamental cellular process for the degradation and recycling of cellular components, and its modulation is a promising therapeutic strategy for various diseases, including triple-negative breast cancer (TNBC).^{[2][3]} **LYN-1604** has been shown to bind directly to ULK1 with a dissociation constant (Kd) in the

nanomolar range (291.4 nM) and activate its kinase activity with an EC50 of 18.94 nM.[1][4][5] This activation triggers a signaling cascade leading to autophagy and, in some contexts, apoptosis.[2][3]

Confirmation of **LYN-1604**'s engagement with ULK1 in cells is paramount. This guide compares several established methods to achieve this, categorized into direct and indirect approaches.

Direct Target Engagement Methods

Direct methods provide evidence of the physical interaction between **LYN-1604** and ULK1 inside the cell.

Cellular Thermal Shift Assay (CETSA®)

Principle: CETSA is based on the principle that ligand binding stabilizes a target protein, leading to an increase in its thermal stability.[4][6] When cells are heated, proteins denature and aggregate. The presence of a binding ligand like **LYN-1604** can increase the melting temperature (T_m) of its target protein, ULK1. This change in thermal stability is then quantified, typically by Western blotting for the soluble fraction of the target protein at different temperatures.[7][8]

Experimental Protocol: Western Blot-Based CETSA

- Cell Treatment: Culture cells to 80-90% confluency. Treat cells with **LYN-1604** at various concentrations or a vehicle control for a specified time.
- Heating: Harvest and resuspend cells in a suitable buffer. Aliquot the cell suspension into PCR tubes and heat them to a range of temperatures (e.g., 40-70°C) for 3 minutes using a PCR cycler, followed by cooling to room temperature.[6]
- Cell Lysis: Lyse the cells by freeze-thaw cycles (e.g., three cycles in liquid nitrogen followed by thawing at 25°C).[9]
- Separation of Soluble and Aggregated Proteins: Centrifuge the lysates at high speed (e.g., 20,000 x g) for 20 minutes at 4°C to pellet the aggregated proteins.

- Protein Quantification and Western Blotting: Collect the supernatant containing the soluble proteins. Normalize the protein concentration of all samples. Analyze the levels of soluble ULK1 by SDS-PAGE and Western blotting using a specific anti-ULK1 antibody.
- Data Analysis: Quantify the band intensities and plot the percentage of soluble ULK1 as a function of temperature for both treated and untreated samples. A shift in the melting curve to a higher temperature in the **LYN-1604**-treated samples indicates target engagement.

Diagram: CETSA Experimental Workflow

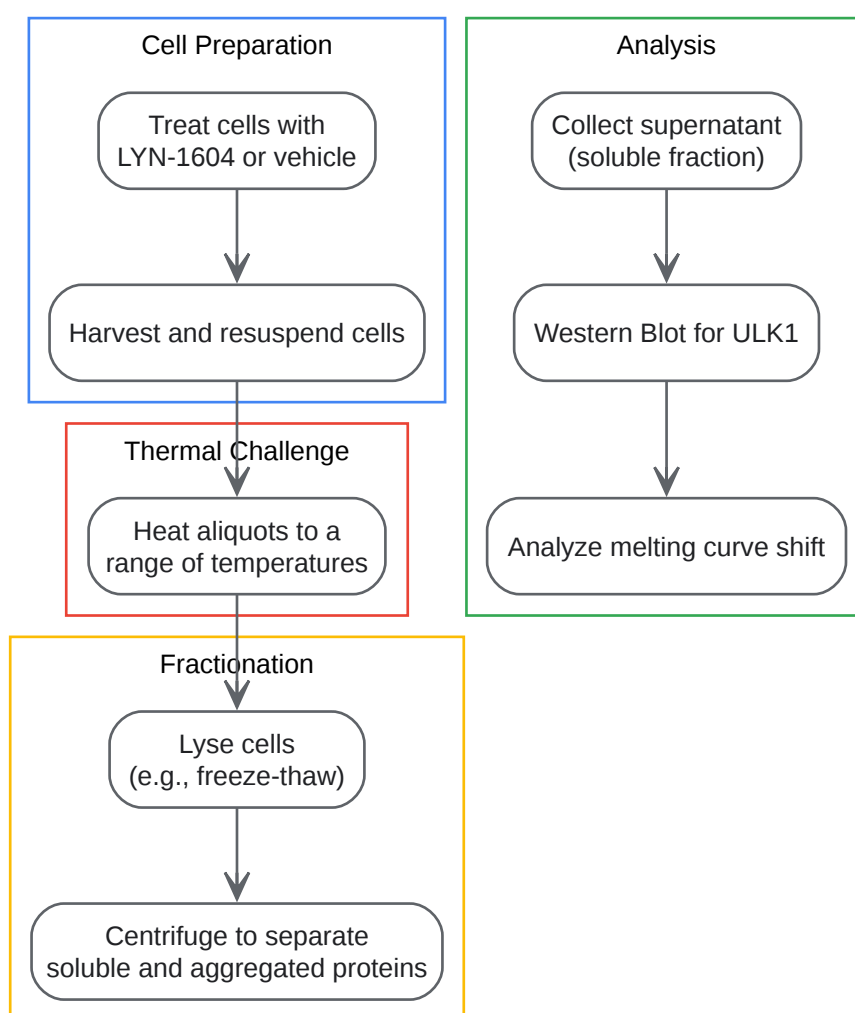

[Click to download full resolution via product page](#)

Caption: Workflow for the Cellular Thermal Shift Assay (CETSA).

NanoBRET™ Target Engagement Assay

Principle: The NanoBRET™ (Bioluminescence Resonance Energy Transfer) assay is a proximity-based method that measures compound binding in live cells.[1][3] The target protein (ULK1) is fused to a NanoLuc® luciferase (the energy donor). A cell-permeable fluorescent tracer that binds to ULK1 is added (the energy acceptor). When the tracer is bound to the NanoLuc®-ULK1 fusion, BRET occurs upon addition of the luciferase substrate. A test compound like **LYN-1604** will compete with the tracer for binding to ULK1, leading to a decrease in the BRET signal in a dose-dependent manner.[10][11]

Experimental Protocol: NanoBRET™ Target Engagement Assay

- **Cell Transfection:** Co-transfect cells (e.g., HEK293T) with a vector expressing the NanoLuc®-ULK1 fusion protein.
- **Cell Plating:** Plate the transfected cells into a 96-well or 384-well white assay plate.
- **Compound and Tracer Addition:** Add **LYN-1604** at various concentrations to the cells, followed by the addition of the specific NanoBRET™ tracer at its predetermined optimal concentration.
- **Equilibration:** Incubate the plate at 37°C in a CO2 incubator to allow the binding to reach equilibrium.
- **Signal Detection:** Add the NanoBRET™ Nano-Glo® Substrate and the Extracellular NanoLuc® Inhibitor.[3] Immediately measure the donor emission (460 nm) and acceptor emission (610 nm) using a luminometer capable of detecting filtered luminescence.
- **Data Analysis:** Calculate the NanoBRET™ ratio (acceptor emission / donor emission). Plot the NanoBRET™ ratio against the concentration of **LYN-1604** to determine the IC50 value, which reflects the compound's affinity for ULK1 in the cellular environment.

Diagram: NanoBRET™ Assay Principle

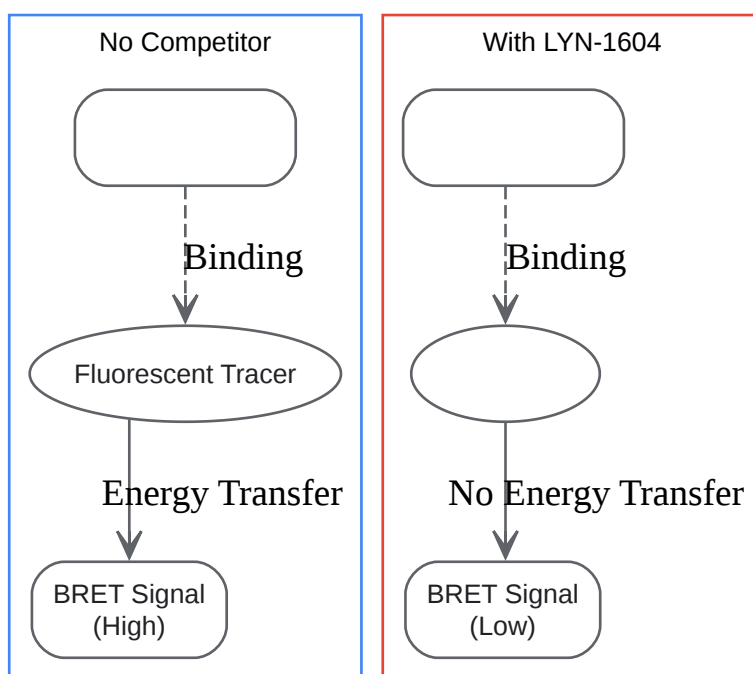

[Click to download full resolution via product page](#)

Caption: Principle of the NanoBRET™ Target Engagement Assay.

Indirect Target Engagement & Downstream Functional Assays

Indirect methods confirm target engagement by measuring the functional consequences of **LYN-1604** binding to ULK1.

Phosphorylation of ULK1 Substrates

Principle: As **LYN-1604** is a ULK1 agonist, it should increase the kinase activity of ULK1, leading to increased phosphorylation of its downstream substrates. A key direct substrate of ULK1 is Autophagy-related protein 13 (mATG13).[5] Measuring the phosphorylation of mATG13 at serine 318 can serve as a direct readout of ULK1 activation by **LYN-1604** in cells.[5]

Experimental Protocol: Western Blot for Phospho-mATG13

- Cell Treatment: Treat cells with varying concentrations of **LYN-1604** for a defined period (e.g., 24 hours).[4]

- Cell Lysis: Lyse the cells in a buffer containing phosphatase and protease inhibitors to preserve the phosphorylation state of proteins.
- Protein Quantification: Determine the protein concentration of each lysate.
- Western Blotting: Separate equal amounts of protein by SDS-PAGE and transfer to a PVDF membrane.
- Immunodetection: Probe the membrane with a primary antibody specific for phosphorylated mATG13 (Ser318). Subsequently, strip the membrane and re-probe with an antibody for total mATG13 or a loading control (e.g., GAPDH or β -actin) to ensure equal protein loading.
- Data Analysis: Quantify the band intensities for phospho-mATG13 and total mATG13. An increase in the ratio of phospho-mATG13 to total mATG13 with increasing concentrations of **LYN-1604** indicates ULK1 activation.

Analysis of Autophagy Markers

Principle: ULK1 activation initiates autophagy. This process involves the conversion of microtubule-associated protein 1A/1B-light chain 3 (LC3) from its cytosolic form (LC3-I) to its lipidated, autophagosome-associated form (LC3-II).[4] Other markers include the upregulation of Beclin-1 and the degradation of p62/SQSTM1, a protein that is incorporated into autophagosomes and degraded.[3][4]

Experimental Protocol: Western Blot for Autophagy Markers

- Cell Treatment: Treat cells with **LYN-1604** at various concentrations for a specified time (e.g., 24 hours).[4]
- Cell Lysis and Western Blotting: Follow the same procedure as described for phospho-mATG13 analysis.
- Immunodetection: Probe membranes with antibodies against LC3, Beclin-1, and p62.
- Data Analysis: Quantify the ratio of LC3-II to LC3-I, the levels of Beclin-1, and the levels of p62. An increase in the LC3-II/LC3-I ratio and Beclin-1 levels, coupled with a decrease in p62 levels, is indicative of autophagy induction via ULK1 activation.

Diagram: **LYN-1604** Signaling Pathway

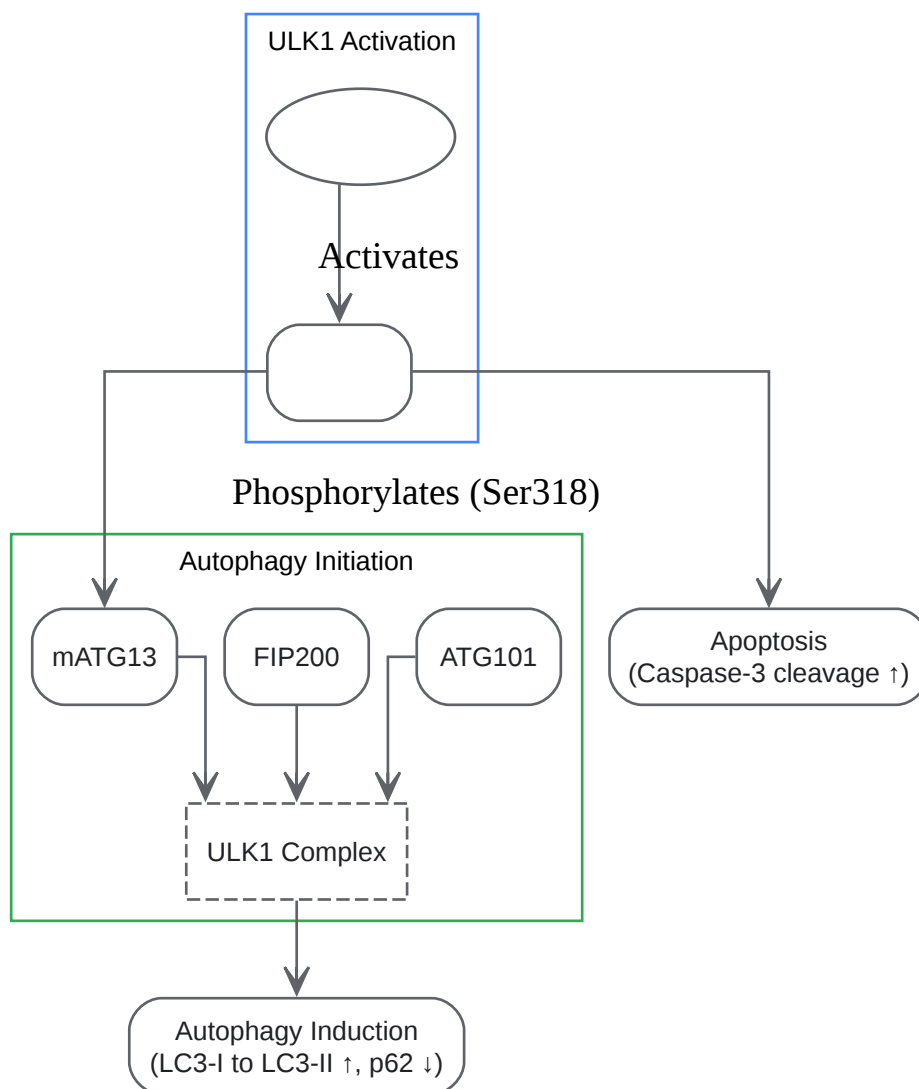

[Click to download full resolution via product page](#)

Caption: Simplified signaling pathway of **LYN-1604**-mediated ULK1 activation.

Comparison of Target Engagement Methods

The choice of assay depends on the specific research question, available resources, and the desired level of evidence for target engagement.

Method	Principle	Type	Pros	Cons
Cellular Thermal Shift Assay (CETSA)	Ligand-induced thermal stabilization of the target protein.[4][6]	Direct	Label-free; performed in intact cells or tissues; reflects physiological conditions.[4]	Lower throughput; requires a specific and sensitive antibody for the target protein; may not work for all proteins.
NanoBRET™ Target Engagement Assay	Bioluminescence Resonance Energy Transfer (BRET) between a tagged target and a fluorescent tracer.[1][3]	Direct	Live-cell assay; quantitative measurement of affinity and residence time; high throughput.[1][3]	Requires genetic modification of the target protein (fusion with NanoLuc®); development of a specific fluorescent tracer is necessary.[3]
Phospho-Substrate Western Blot	Detection of increased phosphorylation of a direct downstream substrate (e.g., mATG13).[5]	Indirect (Proximal)	Measures a direct functional consequence of target activation; uses standard lab techniques.	Relies on the availability of high-quality phospho-specific antibodies; phosphorylation can be transient.
Autophagy Marker Analysis	Measurement of changes in downstream markers of autophagy (LC3-II, p62, Beclin-1).[3][4]	Indirect (Distal)	Confirms the expected biological outcome of ULK1 activation; provides functional validation.	Multiple pathways can influence autophagy, potentially leading to off-target effects confounding the results; less

direct measure of
target
engagement.

Conclusion

Confirming the cellular target engagement of **LYN-1604** is essential for validating its mechanism of action and interpreting its biological effects. This guide has compared several robust methods, each with its own advantages and limitations. For direct evidence of binding in a native cellular environment, CETSA is a powerful label-free option. For high-throughput, quantitative affinity measurements in live cells, the NanoBRET™ assay is an excellent choice, albeit requiring more specialized reagents and protein engineering. Indirect methods, such as monitoring the phosphorylation of ULK1's direct substrate mATG13 and analyzing downstream autophagy markers, provide crucial functional validation of target engagement. A multi-faceted approach, combining a direct binding assay with a functional downstream readout, will provide the most compelling and comprehensive evidence for the on-target activity of **LYN-1604** in cells.

Need Custom Synthesis?

BenchChem offers custom synthesis for rare earth carbides and specific isotopic labeling.

Email: info@benchchem.com or [Request Quote Online](#).

References

- [1. NanoBRET® Target Engagement | Live-Cell Compound Binding Assay \[promega.com\]](#)
- [2. tandfonline.com \[tandfonline.com\]](#)
- [3. news-medical.net \[news-medical.net\]](#)
- [4. Cellular thermal shift assay - Wikipedia \[en.wikipedia.org\]](#)
- [5. pubs.acs.org \[pubs.acs.org\]](#)
- [6. Screening for Target Engagement using the Cellular Thermal Shift Assay - CETSA - Assay Guidance Manual - NCBI Bookshelf \[ncbi.nlm.nih.gov\]](#)

- [7. Cellular thermal shift assay: an approach to identify and assess protein target engagement - PubMed \[pubmed.ncbi.nlm.nih.gov\]](#)
- [8. An update of label-free protein target identification methods for natural active products - PMC \[pmc.ncbi.nlm.nih.gov\]](#)
- [9. researchgate.net \[researchgate.net\]](#)
- [10. reactionbiology.com \[reactionbiology.com\]](#)
- [11. NanoBRET™ Target Engagement Intracellular Assay - NanoBRET Target Engagement Assays - ICE Bioscience \[en.ice-biosci.com\]](#)
- To cite this document: BenchChem. [Confirming LYN-1604 Target Engagement in Cells: A Comparative Guide]. BenchChem, [2026]. [Online PDF]. Available at: [\[https://www.benchchem.com/product/b15604115/docs#confirming-lyn-1604-target-engagement-in-cells-a-comparative-guide\]](https://www.benchchem.com/product/b15604115/docs#confirming-lyn-1604-target-engagement-in-cells-a-comparative-guide)

Disclaimer & Data Validity:

The information provided in this document is for Research Use Only (RUO) and is strictly not intended for diagnostic or therapeutic procedures. While BenchChem strives to provide accurate protocols, we make no warranties, express or implied, regarding the fitness of this product for every specific experimental setup.

Technical Support: The protocols provided are for reference purposes. Unsure if this reagent suits your experiment?

Need Industrial/Bulk Grade? [Request Custom Synthesis Quote](#)

BenchChem

Our mission is to be the trusted global source of essential and advanced chemicals, empowering scientists and researchers to drive progress in science and industry.

Contact

Address: 3281 E Guasti Rd
Ontario, CA 91761, United States
Phone: (601) 213-4426
Email: info@benchchem.com

Contact our Ph.D. Support Team for a compatibility check