

Application Notes and Protocols for GW837016X

In Vitro Cell-Based Assays

Author: BenchChem Technical Support Team. **Date:** April 2026

Compound of Interest

Compound Name: GW837016X

Cat. No.: B15604751

[Get Quote](#)

For Researchers, Scientists, and Drug Development Professionals

Introduction

GW837016X is a novel investigational compound with potential therapeutic applications. To facilitate further research and development, this document provides a detailed protocol for an in vitro cell-based assay to evaluate the cytotoxic and anti-proliferative effects of **GW837016X**. The following protocols are intended as a guide and may require optimization for specific cell lines and experimental conditions.

Mechanism of Action (Hypothetical)

While the precise mechanism of action for **GW837016X** is under investigation, preliminary data suggests it may act as an inhibitor of a key signaling pathway involved in cell proliferation and survival. A proposed pathway involves the inhibition of a receptor tyrosine kinase (RTK), leading to the downstream suppression of the PI3K/Akt and MAPK/ERK signaling cascades. This inhibition is hypothesized to induce cell cycle arrest and apoptosis in cancer cells.

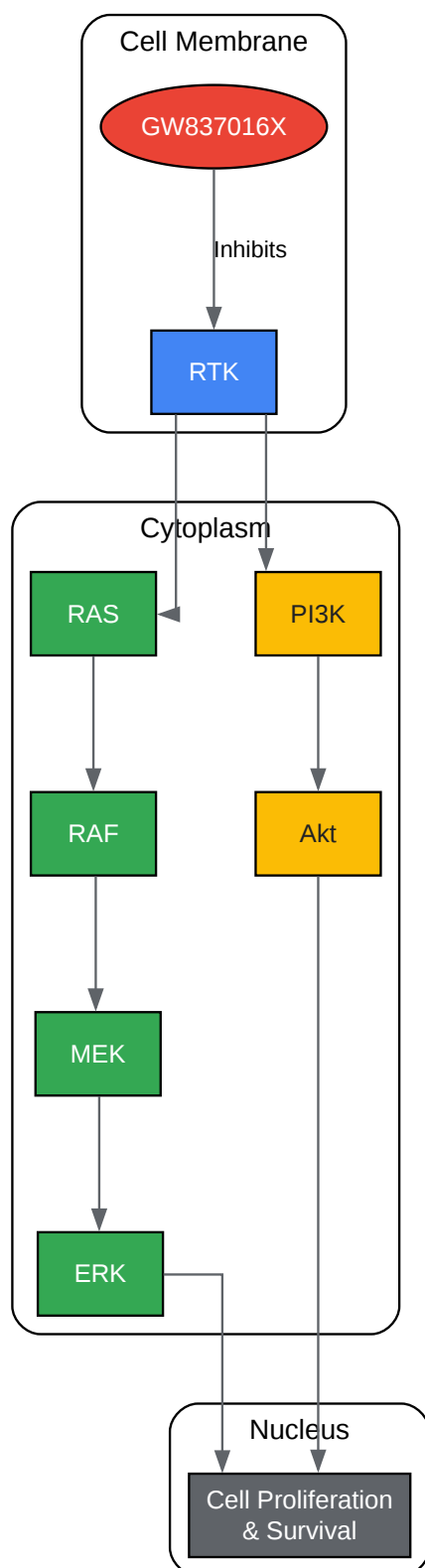

[Click to download full resolution via product page](#)

Caption: Hypothetical signaling pathway of **GW837016X**.

Experimental Protocols

Cell Culture

The A549 human lung carcinoma cell line is recommended for initial screening.

- Growth Medium: F-12K Medium supplemented with 10% Fetal Bovine Serum (FBS) and 1% Penicillin-Streptomycin.
- Culture Conditions: Incubate at 37°C in a humidified atmosphere with 5% CO₂.
- Subculture: Passage cells when they reach 80-90% confluency.

Cytotoxicity Assay (MTT-Based)

This protocol is designed to assess the effect of **GW837016X** on cell viability by measuring the metabolic activity of the cells.

Materials:

- A549 cells
- Complete growth medium
- **GW837016X** stock solution (dissolved in DMSO)
- 96-well clear flat-bottom microplates
- MTT (3-(4,5-dimethylthiazol-2-yl)-2,5-diphenyltetrazolium bromide) solution (5 mg/mL in PBS)
- DMSO (Dimethyl sulfoxide)
- Phosphate-buffered saline (PBS)

Procedure:

- Cell Seeding:

- Trypsinize and count A549 cells.
- Seed 5,000 cells per well in 100 μ L of complete growth medium in a 96-well plate.
- Incubate for 24 hours to allow for cell attachment.
- Compound Treatment:
 - Prepare serial dilutions of **GW837016X** in complete growth medium. The final DMSO concentration should not exceed 0.5%.
 - Remove the old medium from the wells and add 100 μ L of the diluted compound or vehicle control (medium with DMSO).
 - Incubate for 48-72 hours.
- MTT Assay:
 - Add 10 μ L of MTT solution to each well.
 - Incubate for 4 hours at 37°C.
 - Carefully remove the medium.
 - Add 100 μ L of DMSO to each well to dissolve the formazan crystals.
 - Shake the plate for 10 minutes to ensure complete dissolution.
- Data Acquisition:
 - Measure the absorbance at 570 nm using a microplate reader.

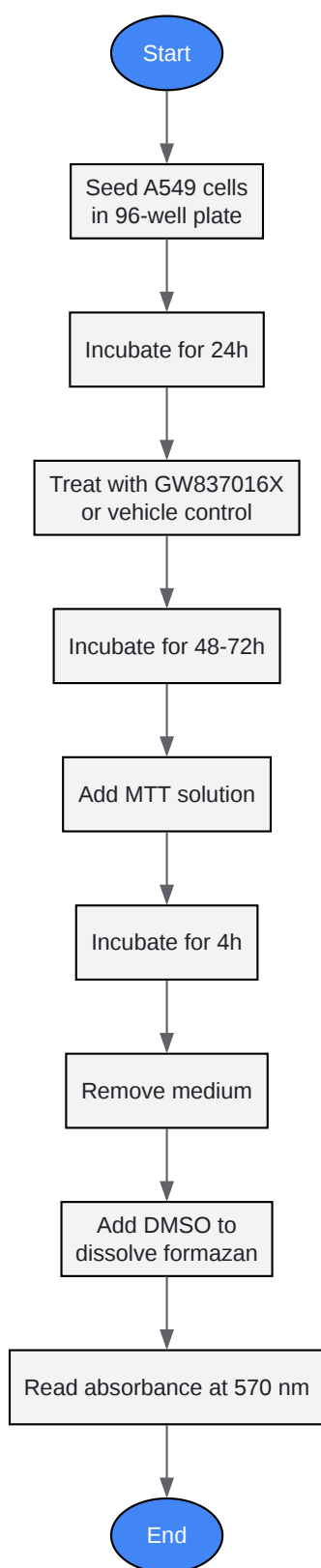

[Click to download full resolution via product page](#)

Caption: MTT-based cytotoxicity assay workflow.

Data Presentation

The following tables summarize hypothetical data obtained from the MTT assay.

Table 1: Cytotoxicity of **GW837016X** on A549 Cells after 48h Treatment

GW837016X Conc. (μM)	Absorbance (570 nm) (Mean \pm SD)	% Viability
0 (Vehicle)	1.25 \pm 0.08	100
0.1	1.18 \pm 0.06	94.4
1	0.95 \pm 0.05	76.0
5	0.62 \pm 0.04	49.6
10	0.31 \pm 0.03	24.8
25	0.15 \pm 0.02	12.0
50	0.08 \pm 0.01	6.4

Table 2: IC50 Values of **GW837016X** on Various Cell Lines

Cell Line	Incubation Time (h)	IC50 (μM)
A549	48	5.2
HCT116	48	8.9
MCF-7	48	12.5
A549	72	3.8

Conclusion

The provided protocols offer a foundational framework for the in vitro evaluation of **GW837016X**. Researchers should adapt and optimize these methods based on their specific experimental goals and available resources. The hypothetical data presented herein illustrates

the potential anti-proliferative effects of **GW837016X** and underscores the importance of further investigation into its mechanism of action.

- To cite this document: BenchChem. [Application Notes and Protocols for GW837016X In Vitro Cell-Based Assays]. BenchChem, [2026]. [Online PDF]. Available at: [<https://www.benchchem.com/product/b15604751/docs#application-notes-and-protocols-for-gw837016x-in-vitro-cell-based-assays>]

Disclaimer & Data Validity:

The information provided in this document is for Research Use Only (RUO) and is strictly not intended for diagnostic or therapeutic procedures. While BenchChem strives to provide accurate protocols, we make no warranties, express or implied, regarding the fitness of this product for every specific experimental setup.

Technical Support: The protocols provided are for reference purposes. Unsure if this reagent suits your experiment?

Need Industrial/Bulk Grade? [Request Custom Synthesis Quote](#)

BenchChem

Our mission is to be the trusted global source of essential and advanced chemicals, empowering scientists and researchers to drive progress in science and industry.

Contact

Address: 3281 E Guasti Rd
Ontario, CA 91761, United States
Phone: (601) 213-4426
Email: info@benchchem.com

[Contact our Ph.D. Support Team for a compatibility check](#)

