

Troubleshooting low knockdown efficiency with ACSM4 siRNA

Author: BenchChem Technical Support Team. **Date:** April 2026

Compound of Interest

Compound Name:	ACSM4 Human Pre-designed siRNA Set A
CAS No.:	365542-77-4
Cat. No.:	B15603885

[Get Quote](#)

Welcome to the Technical Support Center for troubleshooting low knockdown efficiency of Acyl-CoA Synthetase Medium Chain Family Member 4 (ACSM4) siRNA. This guide is designed for researchers, scientists, and drug development professionals to help identify and resolve common issues encountered during gene silencing experiments.

Frequently Asked Questions (FAQs)

Q1: Why am I observing low or no knockdown of my target ACSM4 gene at the mRNA level?

A1: Several factors can contribute to a lack of mRNA knockdown. Below are some common causes and troubleshooting steps:

- **Inefficient siRNA Transfection:** Low transfection efficiency is a primary reason for poor knockdown.[1][2] It is critical to optimize the protocol for your specific cell line.[3][4]
- **Suboptimal siRNA Concentration:** Using an inappropriate siRNA concentration can lead to ineffective silencing. It is recommended to perform a dose-response experiment to determine

the optimal concentration for your experiments.[5][6][7]

- **Poor siRNA Design:** Not all siRNA sequences are equally effective. It is advisable to test multiple siRNA sequences targeting different regions of the ACSM4 mRNA to identify the most potent one.[5] Using a pool of multiple siRNAs can also increase the chances of successful knockdown.[5]
- **Degraded siRNA:** Ensure your siRNA is stored correctly and has not been subjected to degradation by nucleases. Resuspend the siRNA pellet properly to ensure the correct stock concentration.[8]
- **Incorrect Timing of Analysis:** The peak of mRNA knockdown can vary between cell lines and target genes. A time-course experiment (e.g., 24, 48, 72 hours post-transfection) is recommended to determine the optimal time point for analysis.[5]
- **Issues with qPCR Assay:** Problems with your quantitative PCR (qPCR) can mask true knockdown. Verify the efficiency of your qPCR primers and ensure your assay is sensitive enough to detect changes in ACSM4 transcript levels.[9] Consider the location of your qPCR primers relative to the siRNA target site, as this can impact the results.[9]

Q2: My ACSM4 mRNA levels are reduced, but I don't see a corresponding decrease in protein levels. Why is this happening?

A2: A discrepancy between mRNA and protein knockdown is a common issue and can be attributed to several factors:

- **High Protein Stability:** The ACSM4 protein may have a long half-life. Even with efficient mRNA degradation, the existing protein pool can take a significant amount of time to be cleared from the cell.
- **Timing of Analysis:** The peak of mRNA knockdown does not always coincide with the peak of protein reduction. It is advisable to perform a time-course experiment, analyzing protein levels at later time points (e.g., 48, 72, or even 96 hours post-transfection) to allow for protein turnover.

- **Inefficient Knockdown:** While you may observe a statistically significant decrease in mRNA, the remaining transcript levels might still be sufficient to produce a substantial amount of protein.
- **Antibody Issues in Western Blot:** The antibody used for Western blotting may be non-specific or of low quality, leading to the detection of off-target proteins and masking the actual knockdown of ACSM4.[10] It is crucial to validate your antibody's specificity.

Q3: How can I confirm that my siRNA transfection is working effectively?

A3: It is essential to include proper controls in your experiment to verify transfection efficiency:

- **Positive Control siRNA:** Use an siRNA known to effectively knock down a ubiquitously expressed gene (e.g., GAPDH or Lamin A).[5][11] Achieving high knockdown of the positive control indicates that your transfection protocol is effective.[8]
- **Fluorescently Labeled siRNA:** Transfecting a fluorescently labeled, non-targeting siRNA allows for direct visualization of siRNA uptake by the cells using fluorescence microscopy.[2][11] This provides a quick assessment of transfection efficiency.
- **Negative Control siRNA:** A non-targeting or "scrambled" siRNA control is crucial to distinguish sequence-specific silencing from non-specific effects caused by the transfection process itself.[10][12][13]

Q4: What are off-target effects and how can I mitigate them?

A4: Off-target effects occur when an siRNA silences unintended genes due to partial sequence homology.[6] This can lead to misleading results and cellular toxicity.[6] To minimize off-target effects:

- Use the lowest effective siRNA concentration.[6]
- Utilize siRNA sequences with a proven high specificity, often designed using advanced algorithms.

- Consider using a pool of four different siRNAs targeting the same gene, which can reduce the effective concentration of any single siRNA and thereby lower the risk of off-target effects.

Q5: What is the function of ACSM4, and could it influence my experimental results?

A5: ACSM4 (Acyl-CoA Synthetase Medium Chain Family Member 4) is an enzyme that catalyzes the activation of medium-chain fatty acids to their acyl-CoA derivatives, which is a crucial first step in fatty acid metabolism.[14] It is predicted to be involved in acyl-CoA metabolic processes and fatty acid biosynthesis and is located in the mitochondrion.[15][16] The metabolic role of ACSM4 could influence cell viability and proliferation, which might be factors to consider when interpreting your results, especially if you observe changes in cell health post-transfection.

Troubleshooting Guides and Experimental Protocols

Optimizing siRNA Transfection Efficiency

The success of any siRNA experiment hinges on efficient delivery of the siRNA into the cytoplasm of the target cells.[4] The following table provides a starting point for optimizing your transfection protocol.

Parameter	Recommendation	Rationale
Cell Health and Density	Use healthy, low-passage cells that are 30-50% confluent at the time of transfection.[17]	Stressed or overly confluent cells can have reduced transfection efficiency and viability.[18]
Transfection Reagent	Use a reagent specifically designed for siRNA delivery (e.g., Lipofectamine™ RNAiMAX).[3][11]	Reagents designed for plasmid DNA may not be optimal for small RNA molecules.[3]
siRNA Concentration	Test a range of concentrations (e.g., 1-50 nM).[7][17] A good starting point is often 10-30 nM.[4][19]	The optimal concentration is cell-type and target-dependent. Too much siRNA can cause toxicity and off-target effects.[3][5]
Reagent-to-siRNA Ratio	Optimize the ratio of transfection reagent to siRNA as recommended by the manufacturer.	This ratio is critical for the formation of effective transfection complexes.
Complex Formation	Use serum-free media (e.g., Opti-MEM™) to dilute the siRNA and transfection reagent.[5][11]	Serum can interfere with the formation of lipid-siRNA complexes.[11]
Incubation Time	Incubate cells with the transfection complexes for a duration recommended by the reagent manufacturer, often 24-72 hours.	The optimal duration depends on the cell type and the stability of the target mRNA and protein.
Antibiotics	Avoid using antibiotics in the media during transfection.[3][18]	Antibiotics can increase cell death, especially in permeabilized cells.[3]

General siRNA Transfection Protocol (24-well plate)

This protocol is a starting point and should be optimized for your specific cell line and experimental conditions.

- **Cell Seeding:** The day before transfection, seed 15,000-35,000 cells per well in 500 μ L of complete growth medium without antibiotics.[17] The cells should be 30-50% confluent at the time of transfection.[17]
- **siRNA Preparation:** In a sterile tube, dilute 3 pmol of ACSM4 siRNA into 100 μ L of serum-free medium (e.g., Opti-MEM™). Mix gently.[17]
- **Transfection Reagent Preparation:** In a separate sterile tube, add 1-3 μ L of a suitable transfection reagent (e.g., MISSION® siRNA Transfection Reagent) to 100 μ L of serum-free medium. Mix immediately.[17]
- **Complex Formation:** Combine the diluted siRNA and the diluted transfection reagent. Mix gently and incubate at room temperature for 10-15 minutes to allow for the formation of transfection complexes.[17]
- **Transfection:** Add the 200 μ L of the transfection complex mixture dropwise to the cells in the well. Gently rock the plate to ensure even distribution.
- **Incubation:** Incubate the cells at 37°C in a CO2 incubator for 24-72 hours before analysis.
- **Analysis:** Proceed with RNA or protein extraction for knockdown validation.

Validating Knockdown at the mRNA Level (qPCR)

Quantitative real-time PCR (qPCR) is a sensitive method to measure the reduction in target mRNA levels.[19][20]

qPCR Protocol for Knockdown Validation

- **RNA Isolation:** At the desired time point post-transfection, lyse the cells and isolate total RNA using a commercial kit according to the manufacturer's instructions.
- **RNA Quantification and Quality Check:** Determine the concentration and purity (A260/A280 ratio) of the isolated RNA using a spectrophotometer.

- cDNA Synthesis: Synthesize complementary DNA (cDNA) from 1 µg of total RNA using a reverse transcription kit.[21]
- qPCR Reaction Setup: Prepare the qPCR reaction mix containing cDNA template, forward and reverse primers for ACSM4, a stable housekeeping gene (e.g., GAPDH), and a suitable qPCR master mix (e.g., containing TaqMan® probes or SYBR® Green).[19][21]
- qPCR Run: Perform the qPCR reaction using a real-time PCR cycler.
- Data Analysis: Calculate the relative expression of the ACSM4 gene using the $\Delta\Delta C_t$ method, normalizing to the housekeeping gene and comparing to the negative control siRNA-treated sample.[22]

Validating Knockdown at the Protein Level (Western Blot)

Western blotting is used to detect the reduction in the target protein level, which is often the ultimate goal of an RNAi experiment.[12][23]

Western Blot Protocol for Knockdown Validation

- Protein Extraction: At the desired time point post-transfection (typically 48-96 hours), wash the cells with ice-cold PBS and lyse them in a suitable lysis buffer containing protease inhibitors.[23]
- Protein Quantification: Determine the protein concentration of the lysates using a standard protein assay (e.g., BCA assay).
- Sample Preparation: Mix a standardized amount of protein (e.g., 20-30 µg) with Laemmli sample buffer and heat at 95-100°C for 5 minutes.
- SDS-PAGE: Separate the protein samples by size on a polyacrylamide gel.
- Protein Transfer: Transfer the separated proteins from the gel to a membrane (e.g., PVDF or nitrocellulose).
- Blocking: Block the membrane with a suitable blocking buffer (e.g., 5% non-fat milk or BSA in TBST) for 1 hour at room temperature to prevent non-specific antibody binding.

- Primary Antibody Incubation: Incubate the membrane with a validated primary antibody specific for ACSM4 overnight at 4°C.
- Secondary Antibody Incubation: Wash the membrane and incubate with a horseradish peroxidase (HRP)-conjugated secondary antibody for 1 hour at room temperature.
- Detection: Wash the membrane again and detect the protein bands using an enhanced chemiluminescence (ECL) substrate.[\[23\]](#)
- Analysis: Image the blot and perform densitometry analysis to quantify the protein band intensities. Normalize the ACSM4 band intensity to a loading control (e.g., β -actin or GAPDH).

Visualizations

Logical and Experimental Workflows

The following diagrams illustrate logical workflows for troubleshooting and executing an ACSM4 siRNA knockdown experiment.

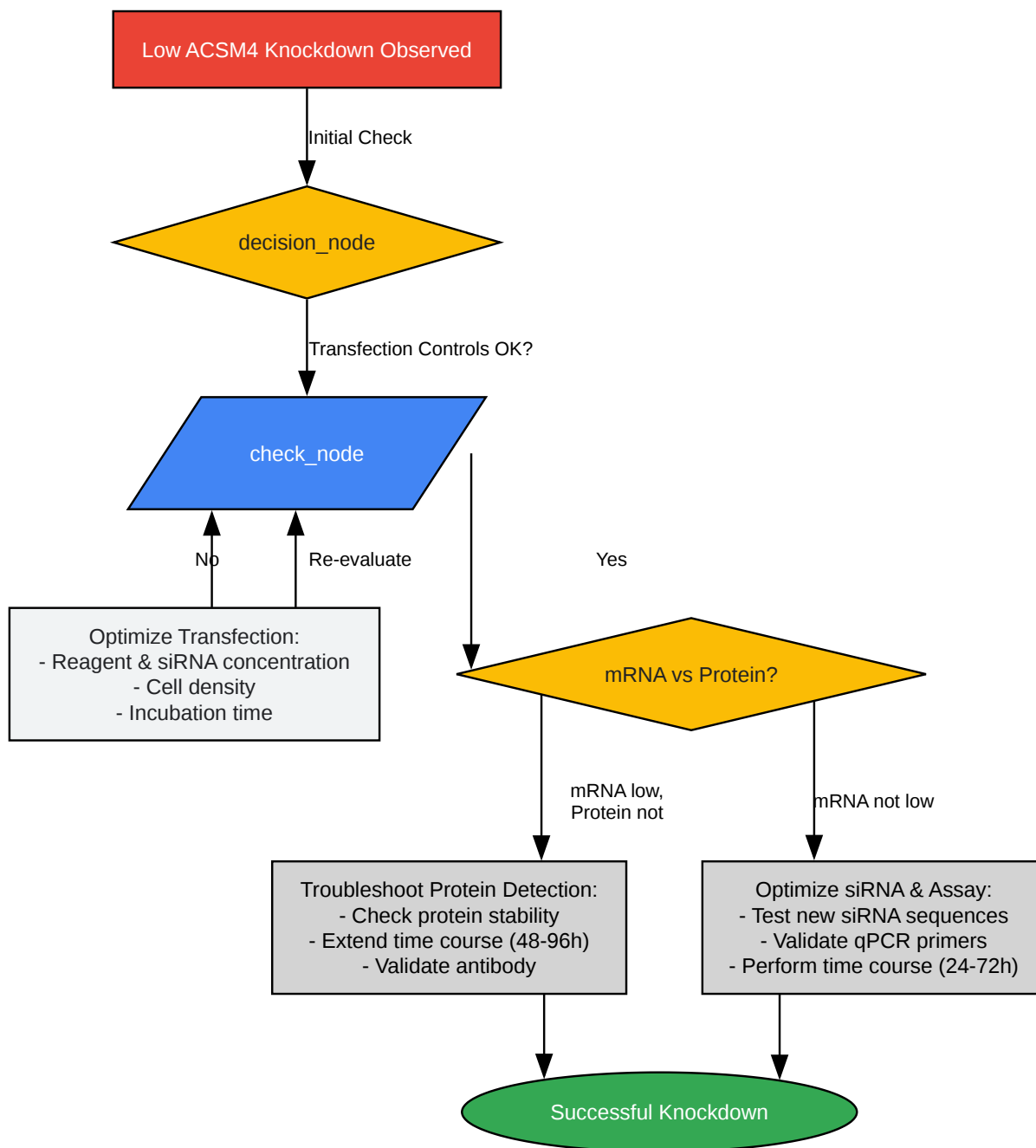

[Click to download full resolution via product page](#)

Caption: Troubleshooting workflow for low siRNA knockdown efficiency.

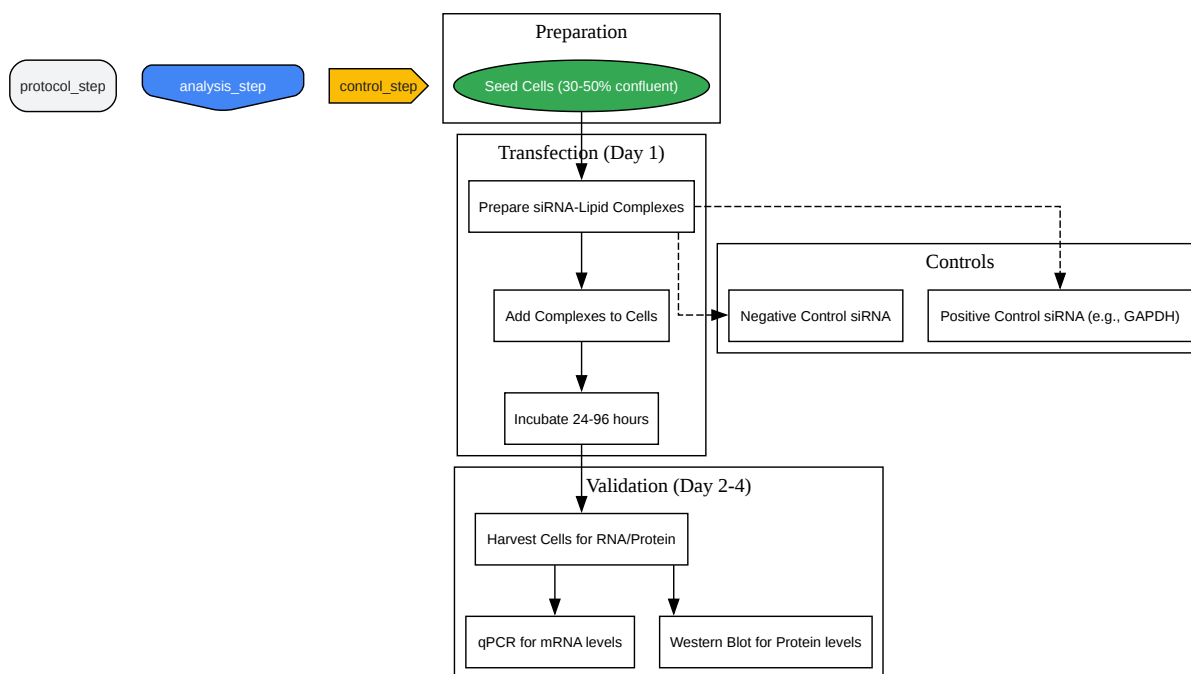

[Click to download full resolution via product page](#)

Caption: Experimental workflow for ACSM4 siRNA knockdown and validation.

ACSM4 Signaling Pathway

ACSM4 is involved in fatty acid metabolism. The diagram below provides a simplified overview of its role.

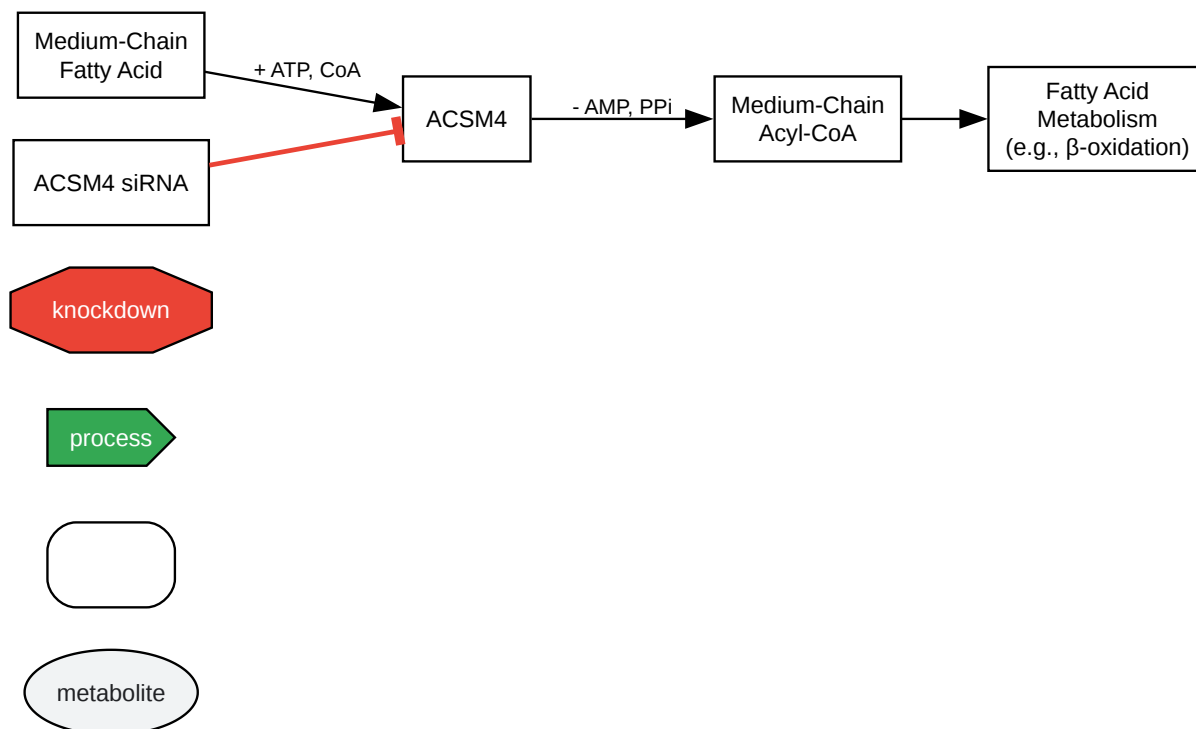

[Click to download full resolution via product page](#)

Need Custom Synthesis?

BenchChem offers custom synthesis for rare earth carbides and specific isotopic labeling.

Email: info@benchchem.com or [Request Quote Online](#).

References

- 1. [benchchem.com](https://www.benchchem.com) [benchchem.com]
- 2. Establishing efficient siRNA knockdown in stem cells using fluorescent oligonucleotides - PubMed [pubmed.ncbi.nlm.nih.gov]
- 3. Optimizing siRNA Transfection | Thermo Fisher Scientific - SG [thermofisher.com]
- 4. Optimizing siRNA Transfection for RNAi | Thermo Fisher Scientific - JP [thermofisher.com]
- 5. [researchgate.net](https://www.researchgate.net) [researchgate.net]
- 6. Guidelines for transfection of siRNA [qiagen.com]

- [7. researchgate.net \[researchgate.net\]](#)
- [8. Top three tips for troubleshooting your RNAi experiment \[horizondiscovery.com\]](#)
- [9. Optimal RNA isolation method and primer design to detect gene knockdown by qPCR when validating Drosophila transgenic RNAi lines - PMC \[pmc.ncbi.nlm.nih.gov\]](#)
- [10. How siRNA Knockdown Antibody Validation Works | Lab Manager \[labmanager.com\]](#)
- [11. Reddit - The heart of the internet \[reddit.com\]](#)
- [12. RNAi Four-Step Workflow | Thermo Fisher Scientific - HK \[thermofisher.com\]](#)
- [13. researchgate.net \[researchgate.net\]](#)
- [14. uniprot.org \[uniprot.org\]](#)
- [15. genecards.org \[genecards.org\]](#)
- [16. ACSM4 acyl-CoA synthetase medium chain family member 4 \[Homo sapiens \(human\)\] - Gene - NCBI \[ncbi.nlm.nih.gov\]](#)
- [17. sigmaaldrich.com \[sigmaaldrich.com\]](#)
- [18. Top Ten Ways to Optimize siRNA Delivery in Cultured Cells | Thermo Fisher Scientific - TW \[thermofisher.com\]](#)
- [19. siRNA-induced Gene Silencing | Thermo Fisher Scientific - SG \[thermofisher.com\]](#)
- [20. Measuring RNAi knockdown using qPCR - PubMed \[pubmed.ncbi.nlm.nih.gov\]](#)
- [21. Validation of siRNA knockdowns by quantitative PCR \[bio-protocol.org\]](#)
- [22. qiagen.com \[qiagen.com\]](#)
- [23. Western Blot Evaluation of siRNA Delivery by pH Responsive Peptides - PMC \[pmc.ncbi.nlm.nih.gov\]](#)
- To cite this document: BenchChem. [Troubleshooting low knockdown efficiency with ACSM4 siRNA]. BenchChem, [2026]. [Online PDF]. Available at: [\[https://www.benchchem.com/product/b15603885/docs#troubleshooting-low-knockdown-efficiency-with-acsm4-sirna\]](https://www.benchchem.com/product/b15603885/docs#troubleshooting-low-knockdown-efficiency-with-acsm4-sirna)

Disclaimer & Data Validity:

The information provided in this document is for Research Use Only (RUO) and is strictly not intended for diagnostic or therapeutic procedures. While BenchChem strives to provide accurate protocols, we make no warranties, express or implied, regarding the fitness of this product for every specific experimental setup.

Technical Support: The protocols provided are for reference purposes. Unsure if this reagent suits your experiment?

Need Industrial/Bulk Grade? [Request Custom Synthesis Quote](#)

BenchChem

Our mission is to be the trusted global source of essential and advanced chemicals, empowering scientists and researchers to drive progress in science and industry.

Contact

Address: 3281 E Guasti Rd
Ontario, CA 91761, United States
Phone: (601) 213-4426
Email: info@benchchem.com

[Contact our Ph.D. Support Team for a compatibility check](#)