

The Dual Role of MYC: Orchestrating Cell Cycle Progression and Apoptosis

Author: BenchChem Technical Support Team. **Date:** April 2026

Compound of Interest

Compound Name: *MYC degrader 1*

Cat. No.: *B15603545*

Get Quote

An In-depth Technical Guide for Researchers, Scientists, and Drug Development Professionals

Abstract

The MYC proto-oncogene is a master transcriptional regulator that plays a pivotal role in a vast array of cellular processes, including proliferation, growth, metabolism, and differentiation.[1] Its deregulation is one of the most common alterations observed in human cancers, making it a highly sought-after therapeutic target.[2][3] This technical guide provides a comprehensive overview of the multifaceted role of MYC in two fundamental and seemingly contradictory cellular processes: cell cycle progression and apoptosis. We delve into the core molecular mechanisms, summarize key quantitative data, provide detailed experimental protocols for studying MYC's function, and present visual diagrams of the critical signaling pathways.

MYC as a Central Regulator of Cell Cycle Progression

MYC acts as a crucial accelerator of the cell cycle, primarily by driving cells from a quiescent state (G0) into the cell cycle and promoting the transition from G1 to S phase.[4][5] This is

achieved through the transcriptional regulation of a wide range of genes that positively influence cell cycle machinery and by repressing negative regulators.[1][6]

Transcriptional Activation of G1-S Phase Regulators

MYC, in a heterodimeric complex with its partner MAX, binds to specific DNA sequences known as E-boxes (CACGTG) in the promoter regions of its target genes.[6] This binding leads to the recruitment of co-activators and chromatin-modifying enzymes, resulting in enhanced gene expression. Key targets of MYC that drive cell cycle progression include:

- **Cyclins:** MYC directly upregulates the expression of Cyclin D1, Cyclin D2, and Cyclin E.[1][6][7] These proteins are essential for the activation of Cyclin-Dependent Kinases (CDKs) that phosphorylate the Retinoblastoma (Rb) protein.
- **Cyclin-Dependent Kinases (CDKs):** MYC promotes the expression of CDK4 and CDK6, the catalytic partners for D-type cyclins, and CDK2, the partner for Cyclin E.[1][6]
- **E2F Transcription Factors:** MYC can induce the expression of E2F1, E2F2, and E2F3, which are critical for the transcription of genes required for DNA synthesis and S-phase entry.[6][8]

Inactivation of Cell Cycle Inhibitors

In addition to activating positive regulators, MYC also facilitates cell cycle progression by neutralizing the effect of CDK inhibitors (CKIs). This is accomplished through several mechanisms:

- **Transcriptional Repression:** MYC can repress the transcription of the CKI genes CDKN1A (encoding p21) and CDKN2B (encoding p15).[1][6]
- **Sequestration:** By promoting the expression of Cyclin D-CDK4/6 complexes, MYC indirectly leads to the sequestration of p27 (encoded by CDKN1B), preventing it from inhibiting Cyclin E-CDK2.[9]

Signaling Pathway for MYC-Driven Cell Cycle Progression

The intricate interplay of these regulatory actions is depicted in the following signaling pathway diagram.

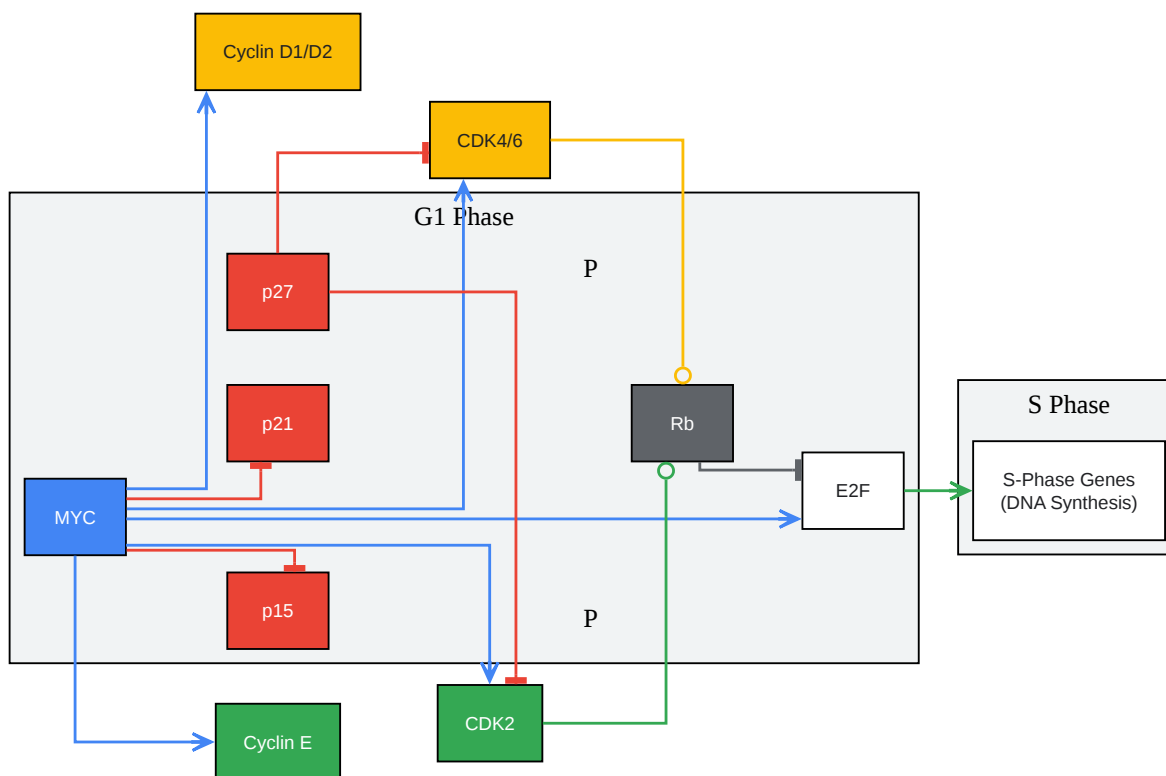

[Click to download full resolution via product page](#)

Caption: MYC promotes G1/S transition by activating cyclins and CDKs and inhibiting their inhibitors.

The Paradoxical Role of MYC in Apoptosis

While a potent driver of proliferation, MYC also has the intrinsic ability to induce apoptosis, or programmed cell death.[10][11] This dual function is a critical failsafe mechanism to eliminate cells with potentially oncogenic levels of MYC expression, thereby preventing tumorigenesis.

[11] The decision between proliferation and apoptosis is context-dependent, influenced by the availability of survival signals and the integrity of cellular stress response pathways.[10]

p53-Dependent Apoptosis

A primary pathway through which MYC induces apoptosis is by activating the p53 tumor suppressor protein.[11][12] This is mainly mediated by the ARF tumor suppressor:

- **ARF Induction:** High levels of MYC expression lead to the transcriptional activation of the ARF gene.[12]
- **MDM2 Inhibition:** The ARF protein binds to and inhibits MDM2, an E3 ubiquitin ligase that targets p53 for proteasomal degradation.[10]
- **p53 Stabilization and Activation:** The inhibition of MDM2 leads to the stabilization and accumulation of p53.[12]
- **Induction of Pro-Apoptotic Genes:** Activated p53 then transcriptionally upregulates pro-apoptotic target genes, such as BAX, PUMA, and NOXA, which ultimately trigger the mitochondrial apoptotic cascade.[11]

p53-Independent Apoptosis

MYC can also trigger apoptosis independently of p53 through several mechanisms:[11][12]

- **Direct Transcriptional Regulation of Bcl-2 Family Members:** MYC can directly upregulate the expression of pro-apoptotic BH3-only proteins like Bim and Bax, while simultaneously repressing the expression of the pro-survival protein Bcl-2.[12] This shifts the balance of Bcl-2 family proteins towards apoptosis.
- **Mitochondrial Priming:** MYC can promote the release of cytochrome c from the mitochondria, a key event in the intrinsic apoptotic pathway, through mechanisms that are not fully elucidated but may involve the activation of Bax.[10]

Signaling Pathways for MYC-Induced Apoptosis

The following diagrams illustrate the p53-dependent and p53-independent pathways of MYC-induced apoptosis.

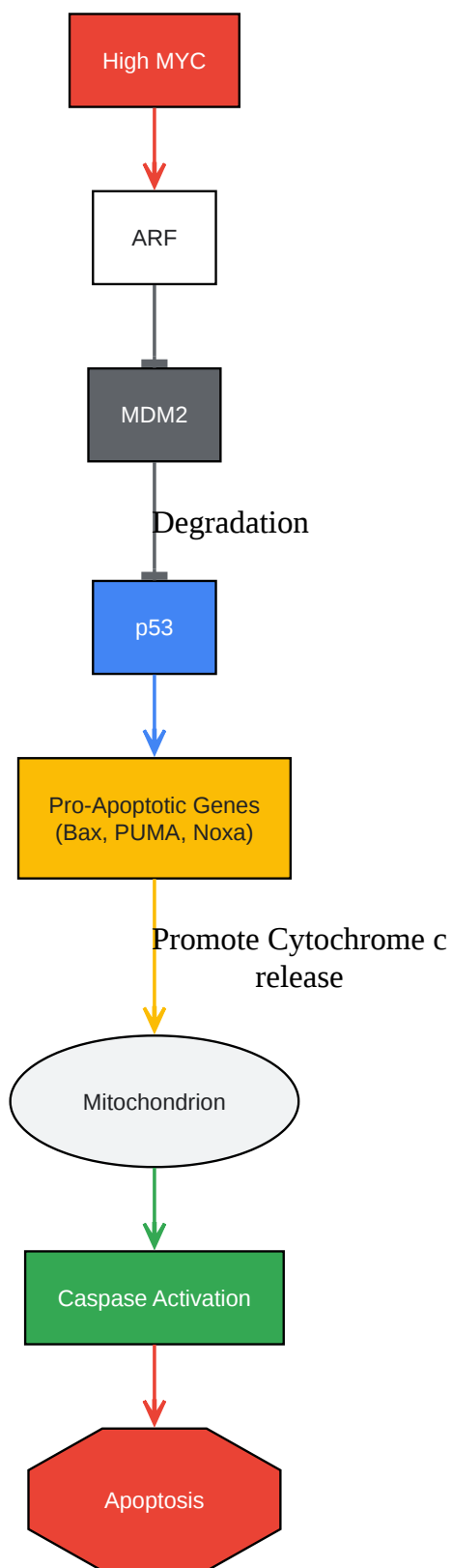

[Click to download full resolution via product page](#)

Caption: p53-dependent apoptosis pathway induced by high levels of MYC.

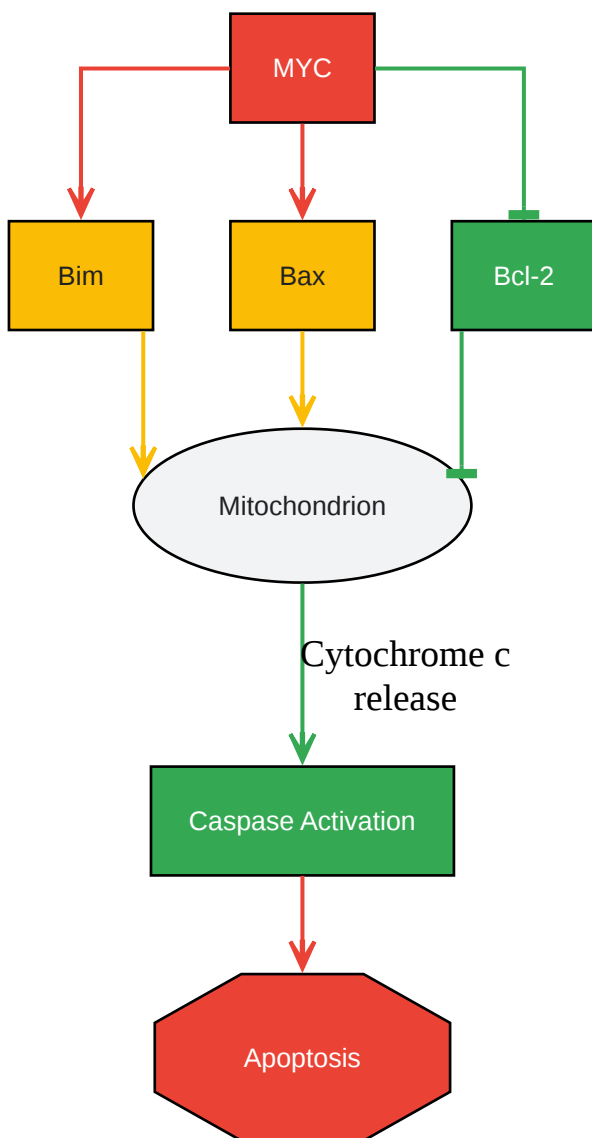

[Click to download full resolution via product page](#)

Caption: p53-independent apoptosis pathway driven by MYC's regulation of Bcl-2 family proteins.

Data Presentation: Quantitative Effects of MYC

The following tables summarize quantitative data from various studies on the impact of MYC on cell cycle distribution and protein expression.

Table 1: Effect of MYC Overexpression on Cell Cycle Distribution

| Cell Line | Condition | % G0/G1 | % S | % G2/M | Reference |
|--------------------------|-------------------------------------|---------|-----|--------|-----------|
| Normal Human Fibroblasts | Normal Growth | >80% | - | - | [13] |
| Normal Human Fibroblasts | Sustained MYCER activation (2 days) | - | - | >70% | [13] |
| 184A1N4 | No IR | - | - | - | [5] |
| 184A1N4 | 6 Gy IR | 30.0% | - | 52.2% | [5] |
| 184A1N4 | 12 Gy IR | 23.3% | - | 55.0% | [5] |
| 184A1N4 | 24 Gy IR | 24.0% | - | 52.7% | [5] |
| 184A1N4-Myc | 6 Gy IR | 42.2% | - | 51.7% | [5] |
| 184A1N4-Myc | 12 Gy IR | ~3% | - | 89.3% | [5] |
| 184A1N4-Myc | 24 Gy IR | ~3% | - | 72.9% | [5] |

Table 2: Quantitative Proteomics of MYC-Regulated Proteins

| Protein Category | Regulation in myc-plus vs. myc-null cells | Functional Implication | Reference |
|----------------------------|---|------------------------------|-----------|
| Proteases | Reduction | Increased cell mass (growth) | [12] |
| Protein Synthesis Pathways | Induction | Increased cell mass (growth) | [12] |
| Anabolic Enzymes | Upregulation | Increased cell mass (growth) | [12] |
| Adhesion Molecules | Reduction | Altered morphology | [12] |
| Actin Network Proteins | Reduction | Altered morphology | [12] |
| Rho Pathway Proteins | Reduction | Altered morphology | [12] |

Experimental Protocols

This section provides detailed methodologies for key experiments used to investigate the role of MYC in cell cycle progression and apoptosis.

Chromatin Immunoprecipitation followed by Sequencing (ChIP-seq) for MYC Target Gene Identification

ChIP-seq is a powerful technique to identify the genomic regions where a specific protein, such as MYC, binds.[14]

Experimental Workflow:

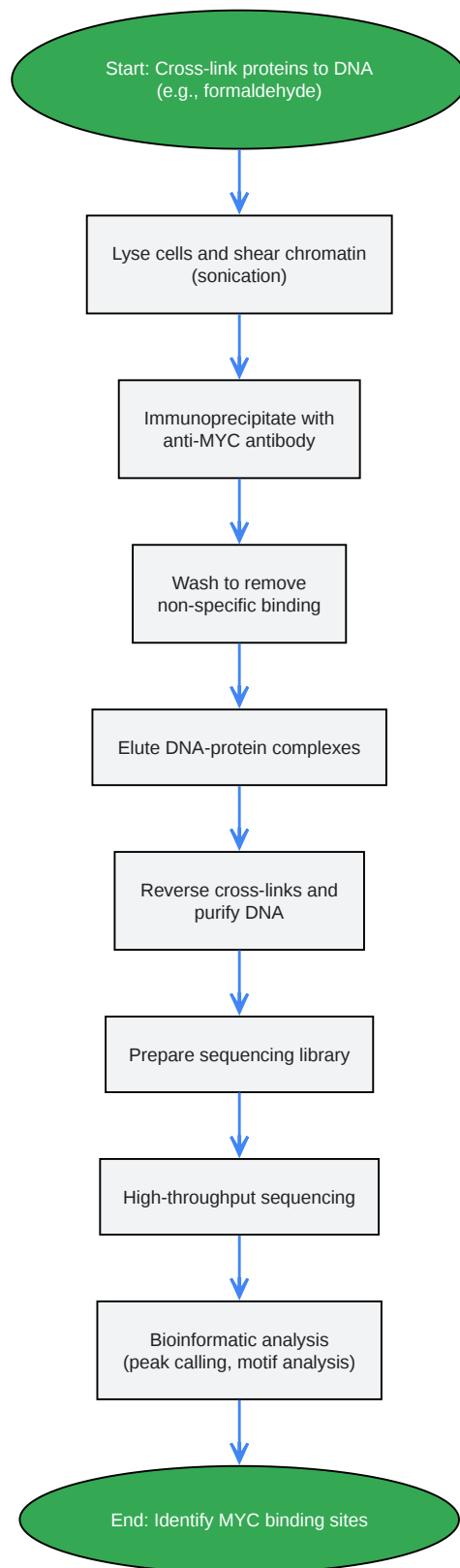

[Click to download full resolution via product page](#)

Caption: Workflow for Chromatin Immunoprecipitation followed by Sequencing (ChIP-seq).

Detailed Protocol:

- Cell Cross-linking:
 - Grow cells to 80-90% confluency.
 - Add formaldehyde to a final concentration of 1% to cross-link proteins to DNA.
 - Incubate for 10 minutes at room temperature with gentle shaking.
 - Quench the reaction by adding glycine to a final concentration of 125 mM.
 - Incubate for 5 minutes at room temperature.
 - Wash cells twice with ice-cold PBS.
- Cell Lysis and Chromatin Shearing:
 - Harvest cells and resuspend in lysis buffer.
 - Lyse the cells to release the nuclei.
 - Resuspend the nuclear pellet in sonication buffer.
 - Sonicate the chromatin to shear the DNA into fragments of 200-500 bp. The optimal sonication conditions should be empirically determined for each cell type.
- Immunoprecipitation:
 - Pre-clear the chromatin with protein A/G beads to reduce non-specific background.
 - Incubate the pre-cleared chromatin with an anti-MYC antibody overnight at 4°C with rotation.
 - Add protein A/G beads and incubate for another 2-4 hours to capture the antibody-protein-DNA complexes.
- Washing and Elution:

- Wash the beads sequentially with low salt, high salt, LiCl, and TE buffers to remove non-specifically bound proteins and DNA.
- Elute the immunoprecipitated complexes from the beads using an elution buffer.
- Reverse Cross-linking and DNA Purification:
 - Add NaCl to the eluate and incubate at 65°C for at least 6 hours to reverse the cross-links.
 - Treat with RNase A and Proteinase K to remove RNA and protein.
 - Purify the DNA using phenol-chloroform extraction or a DNA purification kit.
- Library Preparation and Sequencing:
 - Prepare a sequencing library from the purified DNA according to the manufacturer's protocol (e.g., Illumina).
 - Perform high-throughput sequencing.
- Bioinformatic Analysis:
 - Align the sequencing reads to the reference genome.
 - Use a peak-calling algorithm (e.g., MACS2) to identify regions of significant enrichment (MYC binding sites).
 - Perform downstream analysis such as motif discovery and gene ontology analysis.

TUNEL Assay for Apoptosis Detection

The Terminal deoxynucleotidyl transferase dUTP Nick End Labeling (TUNEL) assay is a common method for detecting DNA fragmentation, a hallmark of late-stage apoptosis.[\[11\]](#)

Experimental Workflow:

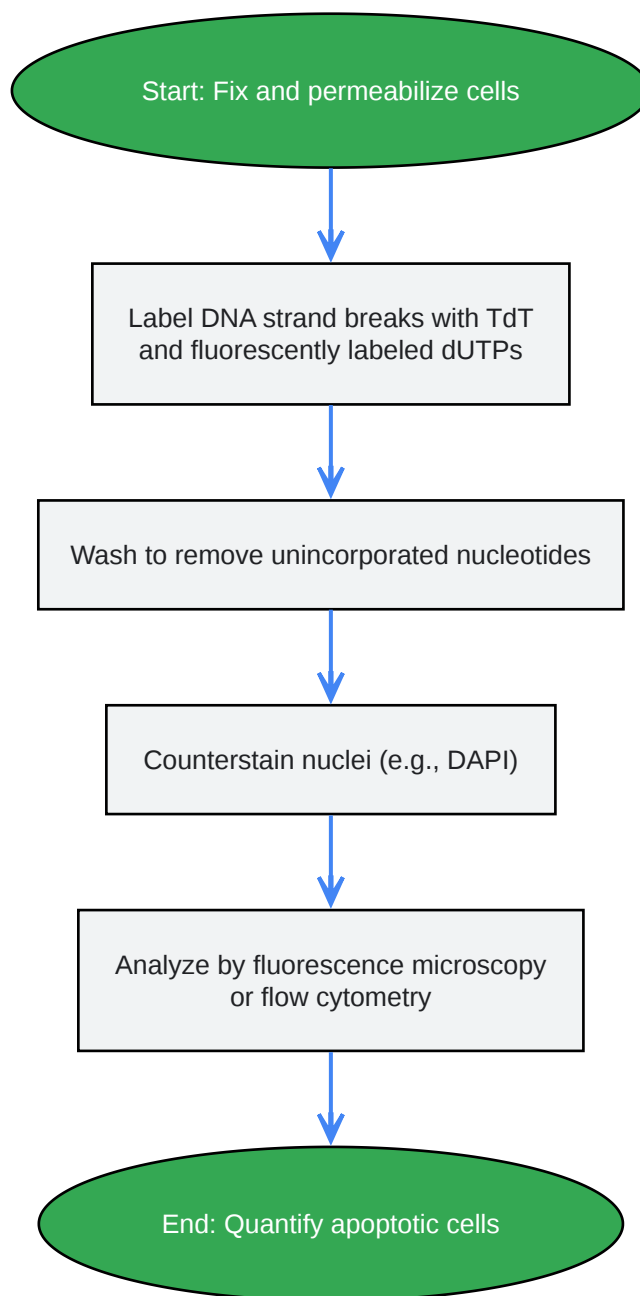

[Click to download full resolution via product page](#)

Caption: Workflow for the TUNEL (Terminal deoxynucleotidyl transferase dUTP Nick End Labeling) assay.

Detailed Protocol:

- Sample Preparation:

- For adherent cells, grow on coverslips. For suspension cells, cytopspin onto slides.
- Fix the cells with 4% paraformaldehyde in PBS for 15-30 minutes at room temperature.
- Wash twice with PBS.
- Permeabilize the cells with 0.1% Triton X-100 in PBS for 2-5 minutes on ice.
- Wash twice with PBS.
- TUNEL Reaction:
 - Equilibrate the slides in TdT reaction buffer for 10 minutes at room temperature.
 - Prepare the TUNEL reaction mixture containing TdT enzyme and fluorescently labeled dUTPs (e.g., FITC-dUTP) according to the manufacturer's instructions.
 - Incubate the slides with the TUNEL reaction mixture in a humidified chamber at 37°C for 1 hour, protected from light.
- Washing and Counterstaining:
 - Stop the reaction by washing the slides with stop/wash buffer.
 - Wash the slides twice with PBS.
 - Counterstain the nuclei with a DNA stain such as DAPI or propidium iodide.
- Analysis:
 - Mount the coverslips with anti-fade mounting medium.
 - Visualize the slides using a fluorescence microscope. TUNEL-positive cells will exhibit bright green fluorescence in the nucleus.
 - Alternatively, the percentage of apoptotic cells can be quantified by flow cytometry.

Cell Cycle Analysis by Propidium Iodide Staining and Flow Cytometry

This method allows for the quantification of cells in different phases of the cell cycle (G0/G1, S, and G2/M) based on their DNA content.[1][15]

Experimental Workflow:

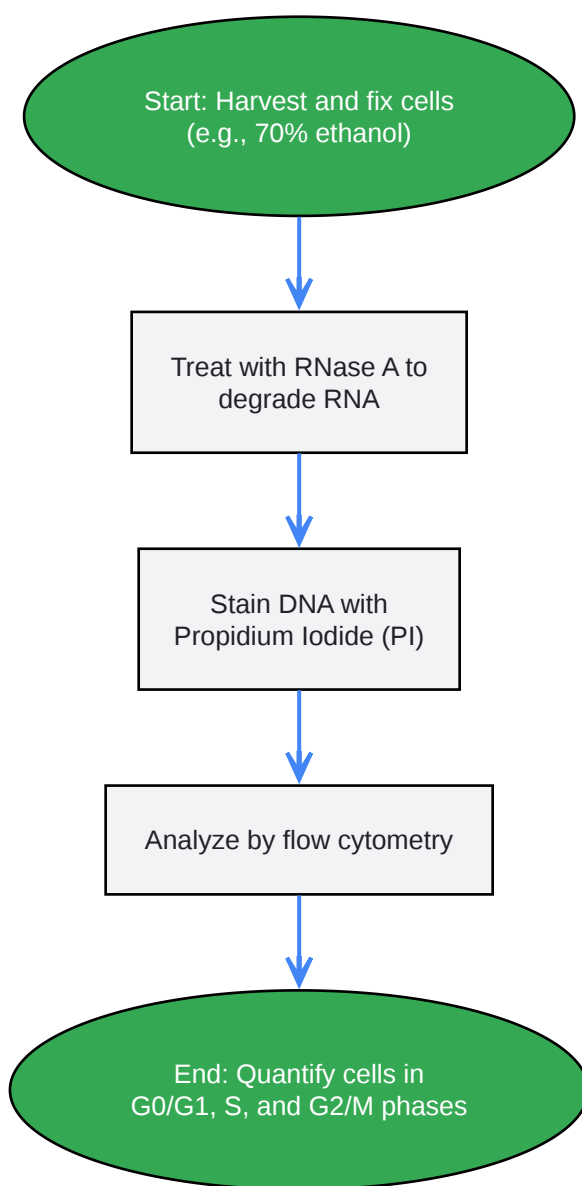

[Click to download full resolution via product page](#)

Caption: Workflow for cell cycle analysis using propidium iodide staining and flow cytometry.

Detailed Protocol:

- Cell Preparation and Fixation:
 - Harvest approximately 1×10^6 cells per sample.
 - Wash the cells with ice-cold PBS.
 - Fix the cells by resuspending the cell pellet in ice-cold 70% ethanol while vortexing gently.
 - Incubate on ice for at least 30 minutes or store at -20°C .
- Staining:
 - Centrifuge the fixed cells and discard the ethanol.
 - Wash the cells with PBS.
 - Resuspend the cell pellet in a staining solution containing propidium iodide (PI) and RNase A.
 - Incubate for 15-30 minutes at room temperature in the dark.
- Flow Cytometry Analysis:
 - Analyze the stained cells using a flow cytometer.
 - Excite the PI with a 488 nm laser and detect the emission in the red channel.
 - Collect data from at least 10,000 events per sample.
 - Generate a histogram of DNA content (PI fluorescence intensity).
 - Use cell cycle analysis software (e.g., FlowJo, ModFit LT) to deconvolute the histogram and determine the percentage of cells in the G0/G1 (2n DNA content), S (intermediate DNA content), and G2/M (4n DNA content) phases.

Conclusion

MYC is a transcription factor with a profound and dichotomous impact on cell fate. Its ability to drive cell cycle progression is central to its role in normal development and its oncogenic potential.[16] Conversely, its capacity to induce apoptosis serves as a critical tumor suppressor mechanism.[11] Understanding the intricate molecular pathways that govern these opposing functions is paramount for the development of effective anti-cancer therapies. The experimental protocols detailed in this guide provide a robust framework for researchers to further dissect the complex biology of MYC and to evaluate the efficacy of novel therapeutic strategies aimed at targeting this master regulator of cellular life and death.[2]

Need Custom Synthesis?

BenchChem offers custom synthesis for rare earth carbides and specific isotopic labeling.

Email: info@benchchem.com or [Request Quote Online](#).

References

- [1. Flow cytometry with PI staining | Abcam \[abcam.com\]](#)
- [2. TUNEL Apoptosis Detection Kit: Principles, Applications, and Step-by-Step Protocol \[absin.net\]](#)
- [3. c-Myc Regulates Cyclin D-Cdk4 and -Cdk6 Activity but Affects Cell Cycle Progression at Multiple Independent Points - PMC \[pmc.ncbi.nlm.nih.gov\]](#)
- [4. mdpi.com \[mdpi.com\]](#)
- [5. Overexpression of c-Myc Alters G1/S Arrest following Ionizing Radiation - PMC \[pmc.ncbi.nlm.nih.gov\]](#)
- [6. bio-rad-antibodies.com \[bio-rad-antibodies.com\]](#)
- [7. Quantitative assessment of cardiac myocyte apoptosis in tissue sections using the fluorescence-based tunel technique enhanced with counterstains - PubMed \[pubmed.ncbi.nlm.nih.gov\]](#)
- [8. The magnitude and temporal dependence of apoptosis early after myocardial ischemia with or without reperfusion - PMC \[pmc.ncbi.nlm.nih.gov\]](#)
- [9. researchgate.net \[researchgate.net\]](#)
- [10. Quantitative proteomic analysis of Myc oncoprotein function - PMC \[pmc.ncbi.nlm.nih.gov\]](#)

- [11. info.gbiosciences.com \[info.gbiosciences.com\]](http://info.gbiosciences.com)
- [12. Quantitative proteomic analysis of Myc oncoprotein function - PubMed \[pubmed.ncbi.nlm.nih.gov\]](https://pubmed.ncbi.nlm.nih.gov)
- [13. Overexpression of MYC causes p53-dependent G2 arrest of normal fibroblasts - PMC \[pmc.ncbi.nlm.nih.gov\]](https://pmc.ncbi.nlm.nih.gov)
- [14. Transcription Factor CHIP-seq Data Standards and Processing Pipeline – ENCODE \[encodeproject.org\]](https://encodeproject.org)
- [15. ucl.ac.uk \[ucl.ac.uk\]](http://ucl.ac.uk)
- [16. vet.cornell.edu \[vet.cornell.edu\]](http://vet.cornell.edu)
- To cite this document: BenchChem. [The Dual Role of MYC: Orchestrating Cell Cycle Progression and Apoptosis]. BenchChem, [2026]. [Online PDF]. Available at: [\[https://www.benchchem.com/product/b15603545/docs#the-dual-role-of-myc-orchestrating-cell-cycle-progression-and-apoptosis\]](https://www.benchchem.com/product/b15603545/docs#the-dual-role-of-myc-orchestrating-cell-cycle-progression-and-apoptosis)

Disclaimer & Data Validity:

The information provided in this document is for Research Use Only (RUO) and is strictly not intended for diagnostic or therapeutic procedures. While BenchChem strives to provide accurate protocols, we make no warranties, express or implied, regarding the fitness of this product for every specific experimental setup.

Technical Support: The protocols provided are for reference purposes. Unsure if this reagent suits your experiment?

Need Industrial/Bulk Grade? [Request Custom Synthesis Quote](#)

BenchChem

Our mission is to be the trusted global source of essential and advanced chemicals, empowering scientists and researchers to drive progress in science and industry.

Contact

Address: 3281 E Guasti Rd
Ontario, CA 91761, United States
Phone: (601) 213-4426
Email: info@benchchem.com

Contact our Ph.D. Support Team for a compatibility check