

# Structural Analysis of Anticancer Agent 230

## Binding to ClpP: A Technical Guide

**Author:** BenchChem Technical Support Team. **Date:** April 2026

### Compound of Interest

Compound Name: Anticancer agent 230

Cat. No.: B15603354

[Get Quote](#)

For Researchers, Scientists, and Drug Development Professionals

## Introduction

The human mitochondrial caseinolytic protease P (ClpP) has emerged as a compelling target for anticancer drug development.[1][2] ClpP is a highly conserved serine protease that plays a critical role in maintaining mitochondrial protein homeostasis by degrading misfolded or damaged proteins.[1][2] Under normal physiological conditions, ClpP's proteolytic activity is tightly regulated by its association with the AAA+ chaperone ClpX, which recognizes, unfolds, and translocates substrate proteins into the ClpP degradation chamber.[3][4]

In numerous cancer types, including acute myeloid leukemia and various solid tumors, ClpP is overexpressed, suggesting a specific role in sustaining oncogenesis and tumor metastasis.[1][5] This has led to the development of small-molecule modulators that target ClpP. One such promising strategy involves the hyperactivation of ClpP using agonists. These compounds bind to ClpP and induce its proteolytic activity independent of ClpX, leading to the uncontrolled degradation of essential mitochondrial proteins.[1][4] This "proteostatic collapse" disrupts oxidative phosphorylation, increases reactive oxygen species (ROS), and ultimately triggers apoptosis in cancer cells.[1]

**Anticancer agent 230** is a recently identified ClpP activator with demonstrated anticancer activity.[6][7] It has been shown to induce the degradation of mitochondrial proteins in triple-negative breast cancer cells.[7] This technical guide provides an in-depth analysis of the structural basis of binding for ClpP activators like **Anticancer agent 230**, supported by quantitative data and detailed experimental protocols for its characterization.

## Mechanism of Action: Allosteric Activation of ClpP

Small-molecule ClpP activators, including the imipridone class (e.g., ONC201) and related analogues, function as allosteric agonists.[8][9] The established mechanism, which is the presumed mode of action for **Anticancer agent 230**, involves the following key steps:

- **Binding to Hydrophobic Pockets:** The activators bind to deep hydrophobic pockets, often referred to as H-sites, located on the apical surfaces of the ClpP tetradecamer.[5] These sites are formed at the interface between two adjacent ClpP subunits.[5][10]
- **Conformational Change:** Ligand binding induces a significant conformational change in the ClpP complex. It stabilizes the active, tetradecameric "extended" state, which is typically induced by ClpX binding.[3][9]
- **Pore Opening and Activation:** This structural rearrangement enlarges the axial entrance pores of the ClpP barrel, granting substrate proteins access to the internal proteolytic chamber without the need for the ClpX unfoldase.[9]
- **Uncontrolled Proteolysis:** The activated ClpP proceeds to degrade a broad range of mitochondrial proteins, leading to mitochondrial dysfunction and cell death.[1][9]

The following diagram illustrates the activation pathway of ClpP by a small-molecule agonist.

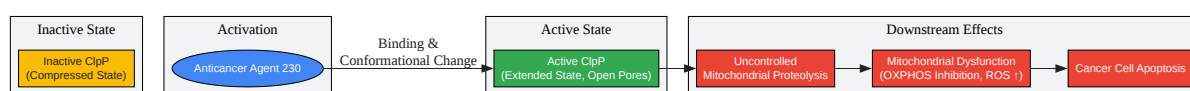

[Click to download full resolution via product page](#)

Mechanism of ClpP activation by an anticancer agent.

## Structural Basis of Binding

X-ray crystallography studies of ClpP in complex with various activators have provided detailed insights into the binding mechanism.[5][11] Co-crystal structures reveal that these compounds exhibit a high degree of shape and charge complementarity with the hydrophobic binding pockets of ClpP.[5][11]

For instance, the structure of human ClpP bound to the activator ONC201 shows that seven ONC201 molecules bind within the pockets between adjacent ClpP subunits.[9] This binding alters the dynamics of the N-terminal loops and modulates the position of the catalytic triad (Ser153, His178, Asp227), leading to activation.[9] The improved potency of second-generation analogues, known as TR compounds, is attributed to enhanced interactions within this pocket. [5]

Table 1: Crystallographic Data for Human ClpP-Agonist Complexes

Compound	PDB ID	Resolution (Å)	Key Interacting Residues (Illustrative)	Reference
ONC201	6DL7	N/A	TYR118, TYR138	[5][9]
ADEP-28	6BBA	N/A	Hydrophobic cleft interactions	[5]

| D9 | 6H23 | N/A | Hydrophobic cleft interactions [[5] |

Note: Specific crystallographic data for **Anticancer agent 230** is not yet publicly available. The data presented are for structurally related ClpP activators.

## Quantitative Analysis of Binding and Activity

The interaction between **Anticancer agent 230** and ClpP can be quantified using various biophysical and biochemical assays. These assays are crucial for determining binding affinity,

potency, and the thermodynamic profile of the interaction.

Table 2: Binding Affinity and Potency of Selected ClpP Activators

Compound	Assay Type	Parameter	Value	Cell Line/System	Reference
ONC201	N/A	Kd	26.8 $\mu$ M	Recombinant hClpP	[9]
TR Compounds	Affinity Chromatography	Binding Affinity	$\sim 10\times$ > ONC201	Recombinant hClpP	[8][12]
ZYZ-17	Activity Assay	EC50	0.24 $\mu$ M	Recombinant hClpP	[6]
ZG111	N/A	Kd	0.25 $\mu$ M	Recombinant hClpP	[9]
(S)-ZG197	Activity Assay	EC50	1.4 $\mu$ M	S. aureus ClpP	[6]
CLPP-1071	Activity Assay	EC50	23.5 nM	Recombinant hClpP	[2]

| CLPP-1071 | Proliferation Assay | IC50 | 4.6 nM | HL60 cells |[2] |

Kd: Dissociation Constant; EC50: Half-maximal Effective Concentration; IC50: Half-maximal Inhibitory Concentration.

## Detailed Experimental Protocols

### Surface Plasmon Resonance (SPR) for Binding Kinetics

SPR is a label-free technique used to measure real-time biomolecular interactions and determine kinetic parameters ( $k_a$ ,  $k_d$ ) and binding affinity (Kd).

Protocol:

- Protein Immobilization:
  - Recombinantly express and purify human ClpP protein.
  - Activate the surface of a CM5 sensor chip using a 1:1 mixture of N-hydroxysuccinimide (NHS) and 1-ethyl-3-(3-dimethylaminopropyl)carbodiimide (EDC).
  - Immobilize ClpP onto the sensor surface via amine coupling in a suitable buffer (e.g., 10 mM sodium acetate, pH 5.0) to a target density.
  - Deactivate any remaining active esters with an injection of 1 M ethanolamine-HCl, pH 8.5. [\[13\]](#)
- Analyte Binding:
  - Prepare a dilution series of **Anticancer agent 230** in a suitable running buffer (e.g., PBS with 0.05% Tween-20 and 1% DMSO).
  - Inject the analyte solutions over the immobilized ClpP surface at a constant flow rate, followed by a dissociation phase with running buffer.
  - Include a reference flow cell (activated and deactivated without protein) to subtract non-specific binding and bulk refractive index changes.
- Data Analysis:
  - Fit the resulting sensorgrams (response units vs. time) to a suitable binding model, such as a 1:1 Langmuir model, to extract  $k_a$ ,  $k_d$ , and calculate  $K_d$  ( $k_d/k_a$ ).[\[13\]](#)

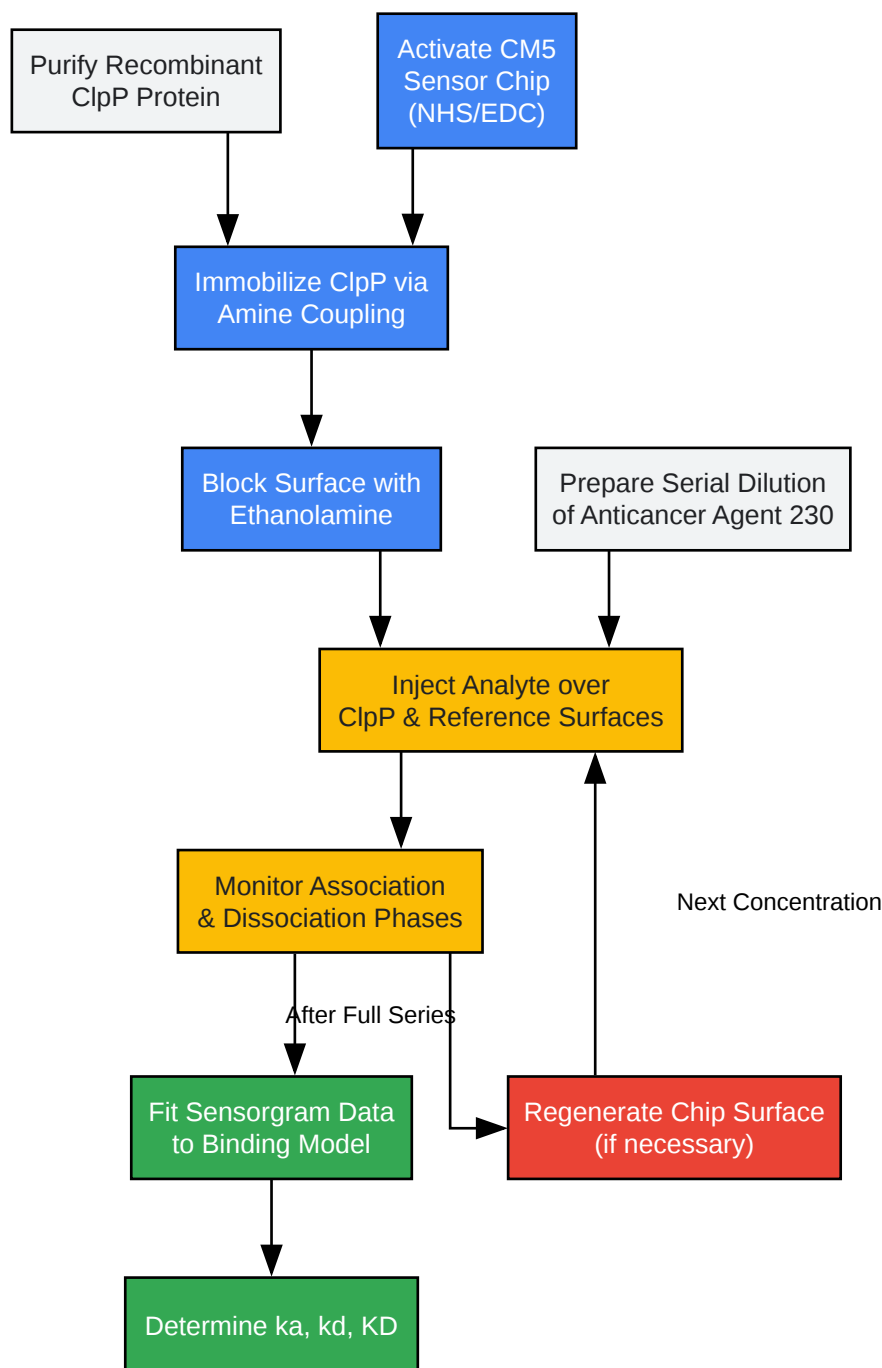

[Click to download full resolution via product page](#)

Experimental workflow for Surface Plasmon Resonance (SPR).

## ClpP Proteolytic Activity Assay

This assay measures the ability of a compound to activate ClpP's enzymatic function using a fluorogenic peptide substrate.

Protocol:

- Assay Setup:
  - Prepare a reaction buffer (e.g., 25 mM HEPES-KOH, pH 7.5, 150 mM KCl, 10 mM MgCl<sub>2</sub>).
  - In a 96- or 384-well microplate, add purified ClpP to the wells.
  - Add varying concentrations of **Anticancer agent 230** (or DMSO control) to the wells and pre-incubate for 15-30 minutes at room temperature.
- Reaction Initiation and Measurement:
  - Initiate the proteolytic reaction by adding a fluorogenic peptide substrate (e.g., Suc-Leu-Tyr-AMC).
  - Immediately begin monitoring the increase in fluorescence (e.g., Ex/Em = 380/460 nm for AMC) over time using a microplate reader.
- Data Analysis:
  - Calculate the initial reaction velocity ( $V_0$ ) from the linear portion of the fluorescence vs. time plot.
  - Plot the initial velocities against the concentration of **Anticancer agent 230**.
  - Fit the resulting curve using a suitable model (e.g., Hill equation) to determine the EC<sub>50</sub> value.<sup>[5]</sup>

## X-ray Crystallography for Structural Determination

This protocol outlines the steps to determine the high-resolution structure of the ClpP-ligand complex.

Protocol:

- Protein Expression and Purification:
  - Overexpress and purify human ClpP to high homogeneity (>95%).

- Concentrate the protein to a suitable level for crystallization (e.g., 5-10 mg/mL).
- Co-crystallization:
  - Incubate the purified ClpP with a molar excess of **Anticancer agent 230**.
  - Screen for crystallization conditions using vapor diffusion methods (sitting or hanging drop) with various commercial or custom-made screens.
  - Optimize lead conditions (e.g., precipitant concentration, pH, temperature) to obtain diffraction-quality crystals.
- Data Collection and Processing:
  - Cryo-protect the crystals and flash-cool them in liquid nitrogen.
  - Collect X-ray diffraction data at a synchrotron source.
  - Process the diffraction data (integrate, scale, and merge) using software like XDS or HKL2000.
- Structure Solution and Refinement:
  - Solve the structure using molecular replacement with a known ClpP structure (e.g., PDB 6BBA) as a search model.
  - Build the model of **Anticancer agent 230** into the resulting electron density map.
  - Perform iterative cycles of model building and refinement to achieve a final structure with good stereochemistry and statistics.[\[5\]](#)

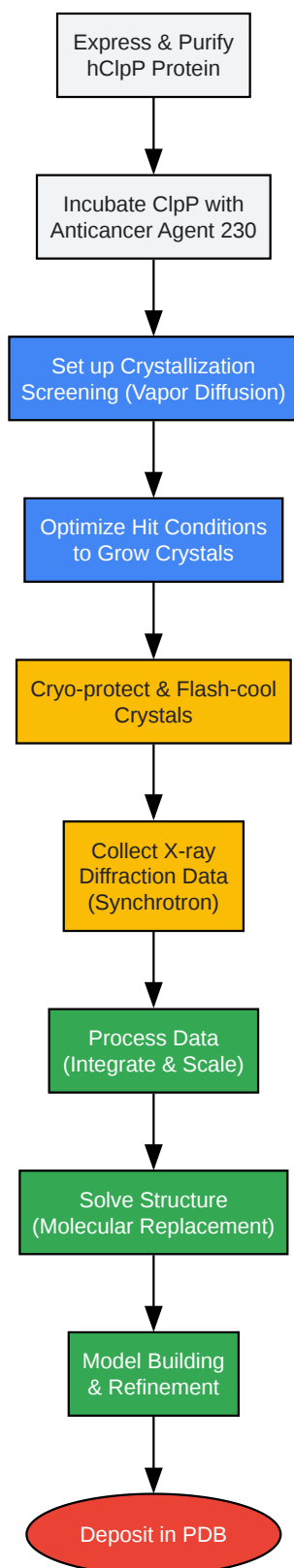

[Click to download full resolution via product page](#)

### Need Custom Synthesis?

BenchChem offers custom synthesis for rare earth carbides and specific isotopic labeling.

Email: [info@benchchem.com](mailto:info@benchchem.com) or [Request Quote Online](#).

## References

- 1. Mitochondrial Protease ClpP: Cancer Marker and Drug Target - PMC [[pmc.ncbi.nlm.nih.gov](https://pubmed.ncbi.nlm.nih.gov/)]
- 2. [researchgate.net](https://www.researchgate.net/) [[researchgate.net](https://www.researchgate.net/)]
- 3. Targeting mitochondrial ClpP: structural insights and therapeutic potential of ClpP agonists in cancer therapy - PMC [[pmc.ncbi.nlm.nih.gov](https://pubmed.ncbi.nlm.nih.gov/)]
- 4. Frontiers | Targeting mitochondrial ClpP: structural insights and therapeutic potential of ClpP agonists in cancer therapy [[frontiersin.org](https://www.frontiersin.org/)]
- 5. Potent ClpP agonists with anticancer properties bind the protease with improved structural complementarity and alter the mitochondrial N-terminome - PMC [[pmc.ncbi.nlm.nih.gov](https://pubmed.ncbi.nlm.nih.gov/)]
- 6. [medchemexpress.com](https://www.medchemexpress.com/) [[medchemexpress.com](https://www.medchemexpress.com/)]
- 7. [medchemexpress.com](https://www.medchemexpress.com/) [[medchemexpress.com](https://www.medchemexpress.com/)]
- 8. [pubs.acs.org](https://pubs.acs.org/) [[pubs.acs.org](https://pubs.acs.org/)]
- 9. [mdpi.com](https://www.mdpi.com/) [[mdpi.com](https://www.mdpi.com/)]
- 10. [researchgate.net](https://www.researchgate.net/) [[researchgate.net](https://www.researchgate.net/)]
- 11. Potent ClpP agonists with anticancer properties bind with improved structural complementarity and alter the mitochondrial N-terminome - PubMed [[pubmed.ncbi.nlm.nih.gov](https://pubmed.ncbi.nlm.nih.gov/)]
- 12. Mitochondrial Protease ClpP is a Target for the Anticancer Compounds ONC201 and Related Analogues - PMC [[pmc.ncbi.nlm.nih.gov](https://pubmed.ncbi.nlm.nih.gov/)]
- 13. [benchchem.com](https://www.benchchem.com/) [[benchchem.com](https://www.benchchem.com/)]
- To cite this document: BenchChem. [Structural Analysis of Anticancer Agent 230 Binding to ClpP: A Technical Guide]. BenchChem, [2026]. [Online PDF]. Available at: [<https://www.benchchem.com/product/b15603354/docs#structural-analysis-of-anticancer-agent-230-binding-to-clpp-a-technical-guide>]

**Disclaimer & Data Validity:**

The information provided in this document is for Research Use Only (RUO) and is strictly not intended for diagnostic or therapeutic procedures. While BenchChem strives to provide accurate protocols, we make no warranties, express or implied, regarding the fitness of this product for every specific experimental setup.

**Technical Support:** The protocols provided are for reference purposes. Unsure if this reagent suits your experiment?

**Need Industrial/Bulk Grade?** [Request Custom Synthesis Quote](#)

## BenchChem

Our mission is to be the trusted global source of essential and advanced chemicals, empowering scientists and researchers to drive progress in science and industry.

### Contact

Address: 3281 E Guasti Rd  
Ontario, CA 91761, United States  
Phone: (601) 213-4426  
Email: [info@benchchem.com](mailto:info@benchchem.com)

[Contact our Ph.D. Support Team for a compatibility check](#)