

Quantifying CD38 Labeling with 6-Alkyne-F-araNAD: Application Notes and Protocols

Author: BenchChem Technical Support Team. **Date:** April 2026

Compound of Interest

Compound Name: 6-Alkyne-F-araNAD

Cat. No.: B15603958

[Get Quote](#)

For Researchers, Scientists, and Drug Development Professionals

Application Notes

The quantification of CD38, a transmembrane glycoprotein with ectoenzymatic activity, is crucial for understanding its role in various physiological and pathological processes, including calcium signaling, NAD⁺ metabolism, and as a therapeutic target in diseases like multiple myeloma.[1][2] The use of **6-Alkyne-F-araNAD**, a cell-impermeable, mechanism-based inhibitor of CD38, in conjunction with fluorescent probes, provides a powerful method to differentiate and quantify cell surface versus intracellular pools of catalytically active CD38.[3]

This approach leverages the covalent labeling of CD38 by **6-Alkyne-F-araNAD**, effectively blocking the enzyme's active site.[4] By first treating live cells with **6-Alkyne-F-araNAD**, researchers can saturate the externally accessible CD38 molecules. Subsequent cell lysis and labeling with a fluorescent, cell-permeable probe, such as SR101-F-araNMN, allows for the specific quantification of the intracellular CD38 population.[3] This technique is particularly valuable for investigating the subcellular localization and trafficking of CD38, which can have significant implications for its biological function and as a drug target.

The alkyne group on **6-Alkyne-F-araNAD** also opens the door for "click chemistry" applications, allowing for the conjugation of various reporter molecules, such as fluorophores or biotin, for diverse detection methodologies.[4][5] This versatility makes it a valuable tool for a range of experimental setups, from in-gel fluorescence and flow cytometry to microscopy.

Key Applications:

- **Differential Quantification of Cell Surface and Intracellular CD38:** Accurately measure the proportion of catalytically active CD38 on the plasma membrane versus within intracellular compartments.[3]
- **Studies of CD38 Trafficking:** Investigate the internalization and subcellular localization of CD38 in response to stimuli or drug treatment.
- **High-Throughput Screening:** Adaptable for screening compounds that may alter CD38 expression or localization.
- **Mechanism of Action Studies:** Elucidate the role of intracellular CD38 in cellular signaling and metabolism.

Quantitative Data Summary

The following table summarizes representative quantitative data obtained using the **6-Alkyne-F-araNAD**-based labeling method to determine the percentage of intracellular CD38 in different cell lines.

Cell Line	Treatment	Percentage of Intracellular CD38	Reference
HL-60	Retinoic Acid (RA) treated	~6.5%	[3]
Raji	Untreated	~4.2%	[3]

Experimental Protocols

Protocol 1: Quantification of Intracellular CD38 using 6-Alkyne-F-araNAD and In-Gel Fluorescence

This protocol describes the differential labeling and quantification of total and intracellular CD38 in cultured cells.

Materials:

- Cells of interest (e.g., HL-60, Raji)
- **6-Alkyne-F-araNAD**
- SR101-F-araNMN (or other suitable fluorescent F-araNAD analog)
- Phosphate Buffered Saline (PBS)
- Cell lysis buffer (e.g., RIPA buffer)
- Protease inhibitors
- SDS-PAGE gels
- Fluorescence gel imager

Procedure:

- Cell Preparation:
 - Culture cells to the desired density.
 - Harvest and wash the cells once with PBS.
 - Resuspend the cell pellet in PBS to a concentration of 1×10^7 cells/mL.
- Blocking of Cell Surface CD38 (for intracellular CD38 quantification):
 - To a 100 μ L aliquot of the cell suspension, add **6-Alkyne-F-araNAD** to a final concentration of 10 μ M.[3]

- Incubate at room temperature for 8 minutes.[3]
- Wash the cells once with 500 μ L of PBS to remove unbound **6-Alkyne-F-araNAD**.
- Labeling of Total and Intracellular CD38:
 - For Intracellular CD38: Resuspend the cell pellet from step 2 in 100 μ L of PBS containing 10 μ M SR101-F-araNMN.
 - For Total CD38 (Control): To a separate 100 μ L aliquot of untreated cells, add 10 μ M SR101-F-araNMN.
 - Incubate all samples at room temperature for 8 minutes.[3]
 - Wash the cells once with 500 μ L of PBS.
- Cell Lysis:
 - Resuspend the cell pellets in an appropriate volume of ice-cold lysis buffer supplemented with protease inhibitors.
 - Incubate on ice for 30 minutes, with vortexing every 10 minutes.
 - Centrifuge at 14,000 x g for 15 minutes at 4°C to pellet cell debris.
 - Collect the supernatant (cell lysate).
- In-Gel Fluorescence Analysis:
 - Determine the protein concentration of each lysate.
 - Mix equal amounts of protein from each sample with SDS-PAGE sample buffer.
 - Load the samples onto an SDS-PAGE gel.
 - After electrophoresis, visualize the fluorescently labeled CD38 bands using a fluorescence gel imager with appropriate excitation and emission settings for the fluorophore used (e.g., for SR101, excitation at ~580 nm and emission at ~600 nm).

- Quantify the fluorescence intensity of the bands corresponding to CD38 using densitometry software.
- Data Analysis:
 - Calculate the percentage of intracellular CD38 using the following formula: $(\text{Fluorescence Intensity of Intracellular CD38} / \text{Fluorescence Intensity of Total CD38}) \times 100$

Visualizations

CD38 Signaling Pathway

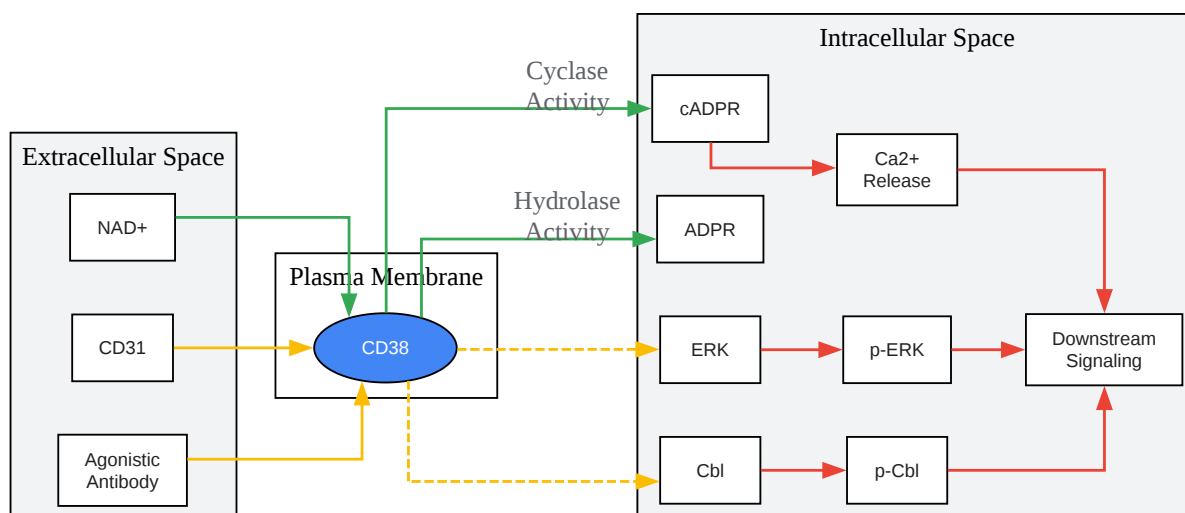

[Click to download full resolution via product page](#)

Caption: CD38 signaling pathways.

Experimental Workflow for Quantifying Intracellular CD38

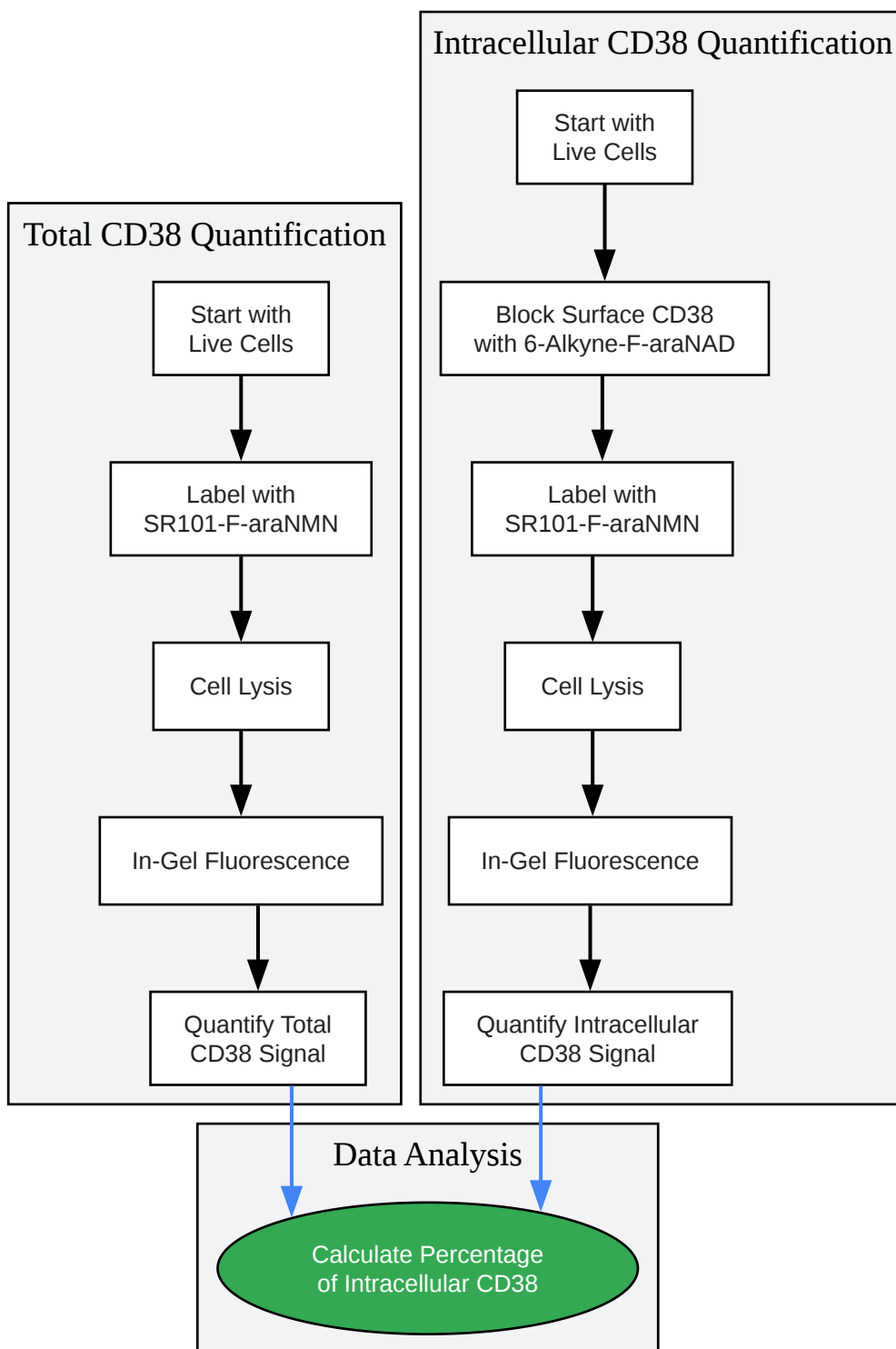

[Click to download full resolution via product page](#)

Caption: Workflow for intracellular CD38 quantification.

Logical Relationship of Reagents and Targets

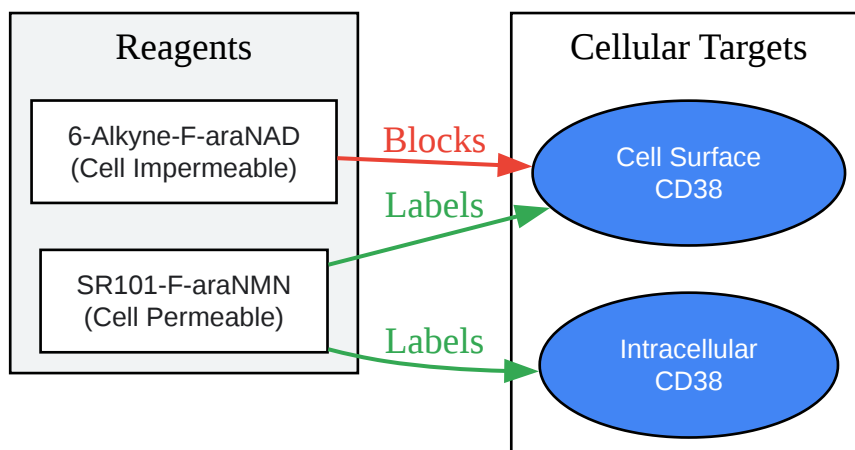

[Click to download full resolution via product page](#)

Caption: Reagent-target interactions.

Need Custom Synthesis?

BenchChem offers custom synthesis for rare earth carbides and specific isotopic labeling.

Email: info@benchchem.com or [Request Quote Online](#).

References

- 1. brd.nci.nih.gov [brd.nci.nih.gov]
- 2. researchgate.net [researchgate.net]
- 3. pubs.acs.org [pubs.acs.org]
- 4. researchgate.net [researchgate.net]
- 5. Mechanism-based small molecule probes for labeling CD38 on live cells - PMC [pmc.ncbi.nlm.nih.gov]
- To cite this document: BenchChem. [Quantifying CD38 Labeling with 6-Alkyne-F-araNAD: Application Notes and Protocols]. BenchChem, [2026]. [Online PDF]. Available at: [<https://www.benchchem.com/product/b15603958/docs#quantifying-cd38-labeling-with-6-alkyne-f-aranad-application-notes-and-protocols>]

Disclaimer & Data Validity:

The information provided in this document is for Research Use Only (RUO) and is strictly not intended for diagnostic or therapeutic procedures. While BenchChem strives to provide accurate protocols, we make no warranties, express or implied, regarding the fitness of this product for every specific experimental setup.

Technical Support: The protocols provided are for reference purposes. Unsure if this reagent suits your experiment?

Need Industrial/Bulk Grade? [Request Custom Synthesis Quote](#)

BenchChem

Our mission is to be the trusted global source of essential and advanced chemicals, empowering scientists and researchers to drive progress in science and industry.

Contact

Address: 3281 E Guasti Rd
Ontario, CA 91761, United States
Phone: (601) 213-4426
Email: info@benchchem.com

[Contact our Ph.D. Support Team for a compatibility check](#)