

Comparative Efficacy of c-Fos Inhibitors: A Guide for Researchers

Author: BenchChem Technical Support Team. **Date:** April 2026

Compound of Interest

Compound Name: *c-Fos-IN-1*

Cat. No.: *B15603387*

[Get Quote](#)

For Immediate Release

This guide provides a comparative analysis of currently available inhibitors targeting the c-Fos protein, a key component of the Activator Protein-1 (AP-1) transcription factor. This document is intended for researchers, scientists, and drug development professionals interested in the therapeutic potential of modulating c-Fos activity in various disease models, including oncology, inflammation, and neurobiology.

Introduction to c-Fos

c-Fos is a proto-oncogene that is rapidly and transiently induced by a wide range of extracellular stimuli, including growth factors, cytokines, and neuronal activation. As a critical component of the AP-1 transcription factor complex, c-Fos dimerizes with proteins of the Jun family to regulate the expression of genes involved in cell proliferation, differentiation, and apoptosis.^[1] Given its central role in these fundamental cellular processes, c-Fos has emerged as a significant therapeutic target for various pathologies, including cancer, inflammatory disorders, and neurological conditions.^{[2][3]} This guide focuses on the efficacy of inhibitors designed to disrupt c-Fos function, with a primary focus on the well-characterized small molecule T-5224 and the peptide-based inhibitor c-Fos-NA.

c-Fos Signaling Pathway

The induction of c-Fos expression is a complex process initiated by various extracellular signals that converge on intracellular signaling cascades. A primary pathway involves the activation of Mitogen-Activated Protein Kinases (MAPKs). Upon stimulation, the MAPK cascade leads to the phosphorylation of transcription factors such as Elk-1 and CREB, which in turn bind to the serum response element (SRE) and cAMP response element (CRE) in the c-Fos promoter, respectively, driving its transcription. Once translated, the c-Fos protein dimerizes with a Jun family protein (e.g., c-Jun) to form the functional AP-1 transcription factor complex. This complex then binds to AP-1 sites in the promoter regions of target genes, regulating their expression.

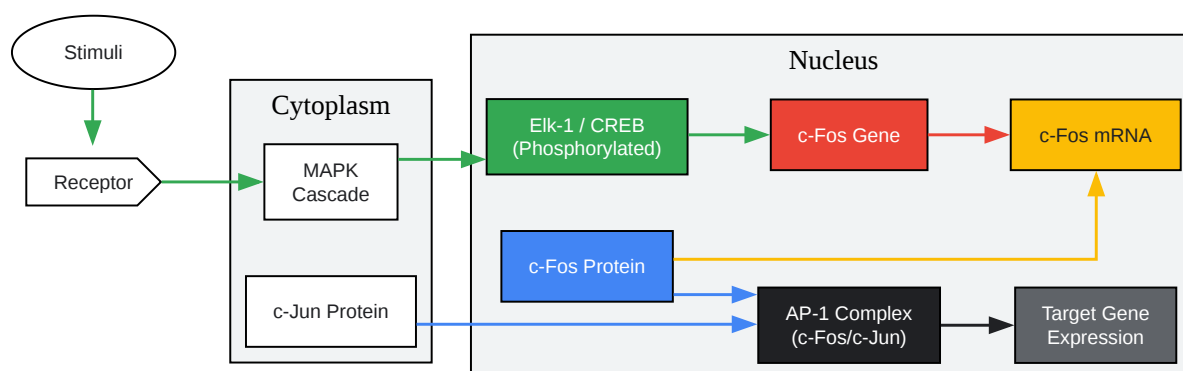

[Click to download full resolution via product page](#)

Caption: Simplified c-Fos signaling pathway.

Quantitative Comparison of c-Fos Inhibitors

The following tables summarize the available quantitative data for T-5224 and provide qualitative efficacy data for c-Fos-NA.

Table 1: In Vitro Efficacy of T-5224

Cell Line	Assay	Endpoint	IC50 / Concentration	Reference
RBL-2H3 (Rat Basophilic Leukemia)	β -hexosaminidase release assay	Mast cell degranulation	18.30 \pm 1.48 μ M	[4]
SW982 (Human Synovial Sarcoma)	ELISA	Production of MMP-1, MMP-3, IL-6, TNF- α	\sim 10 μ M	[5]
SW1353 (Human Chondrosarcoma)	ELISA	Production of MMP-3, MMP-13	Not specified	[5]
HSC-3-M3 (Human Oral Squamous Carcinoma)	Gelatin Zymography	Activity of MMP-2 and MMP-9	40 and 80 μ M (showed suppression)	[6]
Human Nucleus Pulposus Cells	RT-qPCR	IL-1 β -induced up-regulation of Mmp-3, Mmp-13, Adamts-5	Not specified (significant suppression)	[7]

Table 2: In Vivo Efficacy of T-5224

Animal Model	Disease	Dosing	Key Findings	Reference
Male DBA/1J mice	Collagen-Induced Arthritis	3 and 30 mg/kg, oral, daily	64% and 91% inhibition of arthritis development, respectively. Complete protection from joint destruction at 30 mg/kg.	[5]
Mice	Lipopolysaccharide-induced liver injury	300 mg/kg, oral	Reduced lethality from 67% to 27%. Decreased serum levels of TNF α and HMGB1.	[8]
Mice	Oral Cancer Metastasis Model	150 mg/kg	Antimetastatic effect by inhibiting migration and invasion of tumor cells.	[6]

Table 3: Qualitative Efficacy of c-Fos-NA

Model	Assay	Key Findings	Reference
T98G (Human Glioblastoma) cells (in vitro)	Proliferation Assay	Decreased tumor cell proliferation rates.	[2]
U87-MG xenograft in nude mice (in vivo)	Tumor Growth Measurement	Significant reduction in tumor growth with intratumoral injection of c-Fos-NA-containing liposomes.	[1][2]

Experimental Protocols

Detailed methodologies are crucial for the replication and validation of experimental findings. Below are summaries of key experimental protocols for evaluating c-Fos inhibitor efficacy.

In Vitro Inhibition of Mast Cell Degranulation (T-5224)

- Cell Line: RBL-2H3 cells.
- Sensitization: Cells are sensitized overnight with anti-DNP IgE.
- Treatment: Pre-incubation with varying concentrations of T-5224 for 1 hour.
- Stimulation: Stimulation with DNP-HSA for 30 minutes to induce degranulation.
- Endpoint Measurement: The release of β -hexosaminidase into the supernatant is measured as an indicator of degranulation. The IC50 is calculated from the dose-response curve.[4]

In Vivo Glioblastoma Xenograft Model (c-Fos-NA)

- Animal Model: Nude mice.
- Cell Line: U87-MG human glioblastoma cells.
- Tumor Induction: Subcutaneous inoculation of U87-MG cells into the flanks of the mice.

- Treatment: When tumors become palpable, recombinant c-Fos-NA encapsulated in liposomes is injected intratumorally every 36 hours. Control tumors are injected with empty liposomes.
- Endpoint Measurement: Tumor growth is monitored and measured regularly. At the end of the experiment, tumors can be excised for further analysis, such as western blotting for proliferation markers like PCNA.[\[1\]](#)[\[2\]](#)

Experimental Workflow

The following diagram illustrates a general workflow for the preclinical evaluation of a novel c-Fos inhibitor.

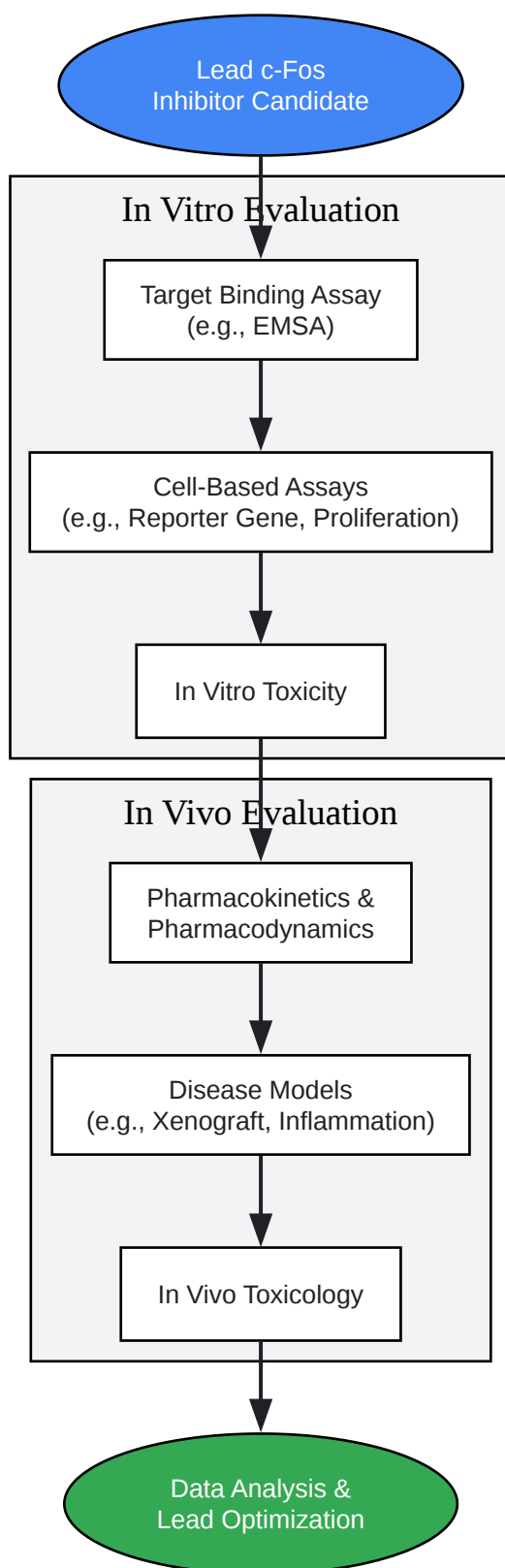

[Click to download full resolution via product page](#)

Caption: Preclinical evaluation workflow for c-Fos inhibitors.

Conclusion

The available data indicates that targeting c-Fos is a viable therapeutic strategy for a range of diseases. The small molecule inhibitor T-5224 has demonstrated significant efficacy in both in vitro and in vivo models of inflammation and cancer, with quantifiable inhibitory concentrations. The peptide-based inhibitor c-Fos-NA shows promise in the context of glioblastoma, though further quantitative studies are needed to fully assess its potency. This guide provides a foundational comparison to aid researchers in the selection and evaluation of c-Fos inhibitors for their specific research needs. As the field of c-Fos inhibition continues to evolve, further studies are warranted to identify and characterize novel inhibitors with improved efficacy and safety profiles.

Need Custom Synthesis?

BenchChem offers custom synthesis for rare earth carbides and specific isotopic labeling.

Email: info@benchchem.com or [Request Quote Online](#).

References

- [1. portlandpress.com](http://portlandpress.com) [portlandpress.com]
- [2. Impairing activation of phospholipid synthesis by c-Fos interferes with glioblastoma cell proliferation - PubMed](#) [pubmed.ncbi.nlm.nih.gov]
- [3. lifecanvastech.com](http://lifecanvastech.com) [lifecanvastech.com]
- [4. Inhibition of c-Fos expression attenuates IgE-mediated mast cell activation and allergic inflammation by counteracting an inhibitory AP1/Egr1/IL-4 axis - PMC](#) [pmc.ncbi.nlm.nih.gov]
- [5. researchgate.net](http://researchgate.net) [researchgate.net]
- [6. researchgate.net](http://researchgate.net) [researchgate.net]
- [7. Successful Treatment of Intracranial Glioblastoma Xenografts With a Monoamine Oxidase B-Activated Pro-Drug - PMC](#) [pmc.ncbi.nlm.nih.gov]
- [8. T-5224, a selective inhibitor of c-Fos/activator protein-1, attenuates lipopolysaccharide-induced liver injury in mice - PubMed](#) [pubmed.ncbi.nlm.nih.gov]
- To cite this document: BenchChem. [Comparative Efficacy of c-Fos Inhibitors: A Guide for Researchers]. BenchChem, [2026]. [Online PDF]. Available at:

[<https://www.benchchem.com/product/b15603387/docs#comparative-efficacy-of-c-fos-inhibitors-a-guide-for-researchers>]

Disclaimer & Data Validity:

The information provided in this document is for Research Use Only (RUO) and is strictly not intended for diagnostic or therapeutic procedures. While BenchChem strives to provide accurate protocols, we make no warranties, express or implied, regarding the fitness of this product for every specific experimental setup.

Technical Support: The protocols provided are for reference purposes. Unsure if this reagent suits your experiment?

Need Industrial/Bulk Grade? [Request Custom Synthesis Quote](#)

BenchChem

Our mission is to be the trusted global source of essential and advanced chemicals, empowering scientists and researchers to drive progress in science and industry.

Contact

Address: 3281 E Guasti Rd
Ontario, CA 91761, United States
Phone: (601) 213-4426
Email: info@benchchem.com

[Contact our Ph.D. Support Team for a compatibility check](#)