

Addressing off-target effects of CD47 targeting peptides

Author: BenchChem Technical Support Team. **Date:** April 2026

Compound of Interest

Compound Name: RS17
Cat. No.: B15603457

[Get Quote](#)

Technical Support Center: CD47 Targeting Peptides

This technical support center provides troubleshooting guidance and frequently asked questions (FAQs) for researchers, scientists, and drug development professionals working with CD47 targeting peptides. Our goal is to help you address common challenges and mitigate off-target effects in your experiments.

Troubleshooting Guide

This guide addresses specific issues that may arise during your experiments with CD47 targeting peptides.

Problem	Possible Cause	Recommended Solution
High Hemolytic Activity Observed in vitro	The peptide sequence or structure may have inherent hemolytic properties.	1. Sequence Modification: Substitute hydrophobic amino acids with hydrophilic ones to decrease overall hydrophobicity. 2. Cyclization: Cyclic peptides may exhibit reduced hemolytic activity compared to their linear counterparts. 3. Formulation: Encapsulate the peptide in nanoparticles to shield it from direct contact with red blood cells (RBCs). ^[1]
Peptide concentration is too high.	Determine the HC50 (the concentration that causes 50% hemolysis) of your peptide to identify a therapeutic window with minimal hemolytic effects. ^{[2][3]}	
Peptide Shows Low Binding Affinity to CD47	Suboptimal peptide design or synthesis.	1. Affinity Maturation: Perform amino acid substitutions at key binding positions to enhance interaction with CD47. 2. Structural Analysis: Use computational modeling to predict the binding interface and guide peptide design.
Incorrect assay conditions.	Optimize buffer pH, salt concentration, and temperature for the binding assay (e.g., Surface Plasmon Resonance or flow cytometry). ^[4]	

<p>Inconsistent Phagocytosis Assay Results</p>	<p>Variability in macrophage activation state.</p>	<p>Standardize the macrophage differentiation and activation protocol. Use consistent sources of primary cells or a stable cell line.</p>
<p>Effector-to-target cell ratio is not optimal.</p>	<p>Titrate the ratio of macrophages to cancer cells to find the optimal condition for observing phagocytosis.</p>	
<p>In vivo Toxicity Observed (e.g., Anemia, Thrombocytopenia)</p>	<p>On-target, off-tumor effects due to ubiquitous CD47 expression on healthy cells, especially aged red blood cells and platelets.[5][6]</p>	<p>1. Dosing Strategy: Implement a "priming" low dose followed by higher maintenance doses. This can help clear aged RBCs first and allow for hematopoietic compensation. [7][8] 2. Peptide Engineering: Develop peptides that selectively bind to tumor-overexpressed CD47 or have a higher affinity for CD47 in the tumor microenvironment. 3. Combination Therapy: Combine the CD47 targeting peptide with a cancer-specific monoclonal antibody to enhance tumor-specific phagocytosis.[9]</p>
<p>Poor Peptide Stability in Plasma</p>	<p>Susceptibility to proteolytic degradation.</p>	<p>1. D-Amino Acid Substitution: Replace L-amino acids with D-amino acids at protease-sensitive sites to increase resistance to degradation.[10] [11] 2. Pegylation: Modify the peptide with polyethylene glycol (PEG) to increase its</p>

hydrodynamic radius and
reduce renal clearance.

Frequently Asked Questions (FAQs)

Here are some frequently asked questions about the off-target effects of CD47 targeting peptides.

1. What are the primary off-target effects of CD47 targeting peptides?

The most significant off-target effect is hematological toxicity, primarily hemolytic anemia (lysis of red blood cells) and thrombocytopenia (low platelet count).[5][12] This occurs because CD47 is ubiquitously expressed on the surface of many healthy cells, including red blood cells and platelets, where it acts as a "marker of self" to prevent their clearance by macrophages.[9][13][14] Blocking this "don't eat me" signal can lead to the unintended destruction of these cells.[15][16]

2. How do CD47 targeting peptides differ from anti-CD47 antibodies in terms of off-target effects?

CD47 targeting peptides are being developed as an alternative to monoclonal antibodies to potentially reduce off-target toxicities. Unlike antibodies, peptides often lack an Fc region, which can mediate antibody-dependent cell-mediated cytotoxicity (ADCC) and complement-dependent cytotoxicity (CDC), potentially reducing the clearance of healthy cells.[10][17] Some studies have shown that specific peptides can bind to CD47 on tumor cells without causing the same degree of hemagglutination (clumping of red blood cells) as some anti-CD47 antibodies.[4]

3. What is the mechanism behind CD47-SIRP α mediated phagocytosis inhibition?

CD47 on the surface of a cell binds to Signal-Regulatory Protein Alpha (SIRP α) on macrophages.[13][18] This interaction triggers a signaling cascade within the macrophage that inhibits phagocytosis, effectively sending a "don't eat me" signal.[18][19] Cancer cells often overexpress CD47 to evade the immune system.[13][20] CD47 targeting peptides work by blocking the CD47-SIRP α interaction, thereby preventing the inhibitory signal and allowing macrophages to engulf and destroy cancer cells.[4][19]

4. What are the key assays to assess the on- and off-target effects of CD47 targeting peptides?

Several key assays are crucial for evaluating the efficacy and safety of CD47 targeting peptides:

- **Binding Assays:** Techniques like Surface Plasmon Resonance (SPR) and flow cytometry are used to determine the binding affinity and specificity of the peptide to CD47.[4]
- **In Vitro Phagocytosis Assay:** This assay co-cultures macrophages with labeled cancer cells in the presence of the peptide to quantify the enhancement of cancer cell engulfment.[10]
- **Hemolysis Assay:** This is a critical safety assay that measures the amount of hemoglobin released from red blood cells upon incubation with the peptide to quantify its hemolytic activity.[2][21][22]
- **In Vivo Toxicity Studies:** Animal models are used to evaluate systemic toxicity, including monitoring for anemia, thrombocytopenia, and other potential side effects.[4]

Experimental Protocols

Hemolysis Assay Protocol

This protocol is a standard method to quantify the hemolytic activity of a peptide.

Materials:

- Freshly collected human or animal red blood cells (RBCs)
- Phosphate-Buffered Saline (PBS), pH 7.4
- Peptide stock solution
- Triton X-100 (1% v/v in PBS) as a positive control for 100% hemolysis
- 96-well microtiter plates
- Spectrophotometer (plate reader)

Procedure:

- Prepare RBC Suspension:
 - Centrifuge whole blood to pellet the RBCs.
 - Wash the RBC pellet with PBS three times, centrifuging and removing the supernatant after each wash.
 - Resuspend the washed RBCs in PBS to a final concentration of 2% (v/v).
- Assay Setup:
 - Add 100 μ L of PBS to each well of a 96-well plate.
 - Add 100 μ L of the peptide stock solution to the first well and perform serial dilutions across the plate.
 - Include wells with 100 μ L of PBS only (negative control) and 100 μ L of 1% Triton X-100 (positive control).
- Incubation:
 - Add 100 μ L of the 2% RBC suspension to each well.
 - Incubate the plate at 37°C for 1 hour with gentle shaking.
- Centrifugation:
 - Centrifuge the plate at 1000 x g for 10 minutes to pellet the intact RBCs.
- Measure Hemoglobin Release:
 - Carefully transfer 100 μ L of the supernatant from each well to a new 96-well plate.
 - Measure the absorbance of the supernatant at 540 nm using a spectrophotometer.
- Calculate Percent Hemolysis:
 - Percent Hemolysis = $[(\text{Abs_sample} - \text{Abs_negative_control}) / (\text{Abs_positive_control} - \text{Abs_negative_control})] \times 100$

In Vitro Phagocytosis Assay Protocol

This protocol measures the ability of a peptide to enhance macrophage-mediated phagocytosis of cancer cells.

Materials:

- Macrophage cell line (e.g., J774A.1) or primary macrophages
- Cancer cell line expressing CD47
- Fluorescent dye for labeling cancer cells (e.g., CFSE or PKH67)
- CD47 targeting peptide
- Control peptide (scrambled sequence)
- 96-well culture plates
- Flow cytometer or fluorescence microscope

Procedure:

- Label Target Cancer Cells:
 - Harvest and wash the cancer cells.
 - Label the cancer cells with a fluorescent dye according to the manufacturer's protocol.
 - Wash the labeled cells to remove excess dye.
- Prepare Macrophages:
 - Plate macrophages in a 96-well plate and allow them to adhere overnight.
- Co-culture and Treatment:
 - Add the labeled cancer cells to the macrophage-containing wells at a specific effector-to-target ratio (e.g., 1:5).

- Add the CD47 targeting peptide at various concentrations. Include wells with a control peptide and no peptide.
- Incubate the co-culture for 2-4 hours at 37°C.
- Quantify Phagocytosis:
 - Flow Cytometry:
 - Gently wash the wells to remove non-phagocytosed cancer cells.
 - Detach the macrophages using a non-enzymatic cell dissociation solution.
 - Analyze the macrophages by flow cytometry to detect the fluorescent signal from the engulfed cancer cells. The percentage of fluorescent macrophages represents the phagocytic activity.
 - Fluorescence Microscopy:
 - Wash the wells to remove non-phagocytosed cells.
 - Fix and stain the macrophages with a fluorescently labeled antibody against a macrophage-specific marker (e.g., F4/80).
 - Image the wells using a fluorescence microscope and quantify the number of macrophages containing fluorescent cancer cells.

Visualizations

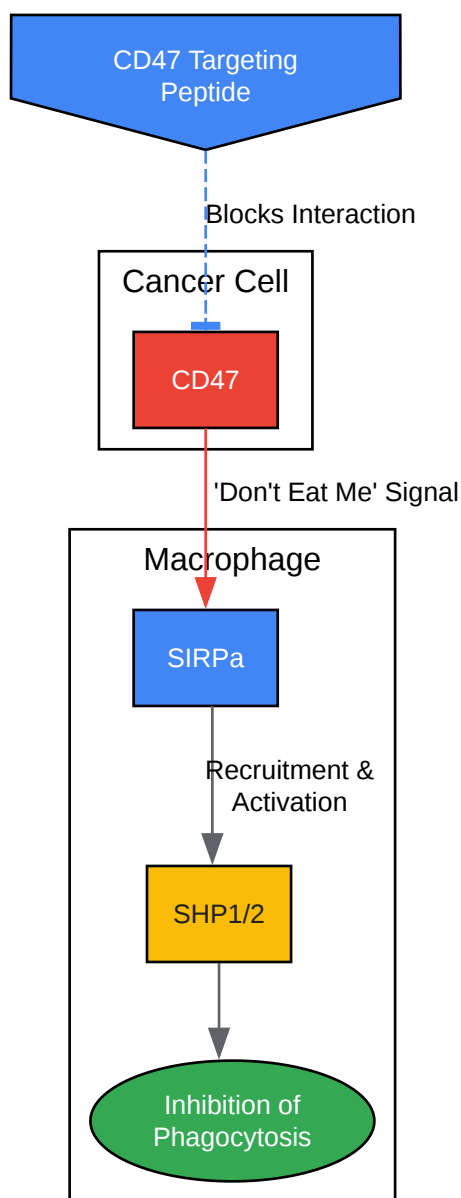

[Click to download full resolution via product page](#)

Caption: CD47-SIRP α Signaling Pathway and Peptide Inhibition.

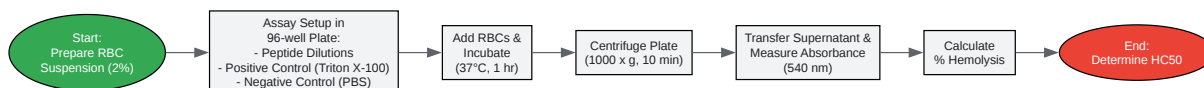

[Click to download full resolution via product page](#)

Caption: Experimental Workflow for Hemolysis Assay.

Need Custom Synthesis?

BenchChem offers custom synthesis for rare earth carbides and specific isotopic labeling.

Email: info@benchchem.com or [Request Quote Online](#).

References

- [1. RSC - Page load error \[pubs.rsc.org\]](#)
- [2. Traditional and Computational Screening of Non-Toxic Peptides and Approaches to Improving Selectivity - PMC \[pmc.ncbi.nlm.nih.gov\]](#)
- [3. benchchem.com \[benchchem.com\]](#)
- [4. Discovery of Anti-CD47 Peptides as Innate Immune Checkpoint Inhibitors - PMC \[pmc.ncbi.nlm.nih.gov\]](#)
- [5. heraldopenaccess.us \[heraldopenaccess.us\]](#)
- [6. oncotarget.com \[oncotarget.com\]](#)
- [7. mdpi.com \[mdpi.com\]](#)
- [8. researchgate.net \[researchgate.net\]](#)
- [9. academic.oup.com \[academic.oup.com\]](#)
- [10. jitc.bmj.com \[jtc.bmj.com\]](#)
- [11. CD47/SIRP \$\alpha\$ blocking peptide identification and synergistic effect with irradiation for cancer immunotherapy - PubMed \[pubmed.ncbi.nlm.nih.gov\]](#)
- [12. researchgate.net \[researchgate.net\]](#)
- [13. CD47 - Wikipedia \[en.wikipedia.org\]](#)
- [14. CD47 | CD molecules | IUPHAR/BPS Guide to PHARMACOLOGY \[guidetopharmacology.org\]](#)
- [15. library.ucdavis.edu \[library.ucdavis.edu\]](#)
- [16. An anti-CD47 antibody binds to a distinct epitope in a novel metal ion-dependent manner to minimize cross-linking of red blood cells - PMC \[pmc.ncbi.nlm.nih.gov\]](#)
- [17. CD47/SIRP \$\alpha\$ blocking peptide identification and synergistic effect with irradiation for cancer immunotherapy - PMC \[pmc.ncbi.nlm.nih.gov\]](#)

- [18. Frontiers | Targeting the CD47/SIRP \$\alpha\$ pathway in malignancies: recent progress, difficulties and future perspectives \[frontiersin.org\]](#)
- [19. CD47/SIRP \$\alpha\$ pathway mediates cancer immune escape and immunotherapy - PMC \[pmc.ncbi.nlm.nih.gov\]](#)
- [20. CD47 \(Cluster of Differentiation 47\) - PMC \[pmc.ncbi.nlm.nih.gov\]](#)
- [21. Hemolytic Activity | Springer Nature Experiments \[experiments.springernature.com\]](#)
- [22. mdpi.com \[mdpi.com\]](#)
- To cite this document: BenchChem. [Addressing off-target effects of CD47 targeting peptides]. BenchChem, [2026]. [Online PDF]. Available at: [\[https://www.benchchem.com/product/b15603457/docs#addressing-off-target-effects-of-cd47-targeting-peptides\]](https://www.benchchem.com/product/b15603457/docs#addressing-off-target-effects-of-cd47-targeting-peptides)

Disclaimer & Data Validity:

The information provided in this document is for Research Use Only (RUO) and is strictly not intended for diagnostic or therapeutic procedures. While BenchChem strives to provide accurate protocols, we make no warranties, express or implied, regarding the fitness of this product for every specific experimental setup.

Technical Support: The protocols provided are for reference purposes. Unsure if this reagent suits your experiment?

Need Industrial/Bulk Grade? [Request Custom Synthesis Quote](#)

BenchChem

Our mission is to be the trusted global source of essential and advanced chemicals, empowering scientists and researchers to drive progress in science and industry.

Contact

Address: 3281 E Guasti Rd
Ontario, CA 91761, United States
Phone: (601) 213-4426
Email: info@benchchem.com

Contact our Ph.D. Support Team for a compatibility check