

Urotensin II Signaling in Mouse Cells: An In-depth Technical Guide

Author: BenchChem Technical Support Team. **Date:** April 2026

Compound of Interest

Compound Name: Urotensin II, mouse acetate

Cat. No.: B15602724

[Get Quote](#)

For Researchers, Scientists, and Drug Development Professionals

This technical guide provides a comprehensive overview of the core signaling pathways activated by Urotensin II (UII) in mouse cells. UII, a potent vasoactive peptide, binds to its G protein-coupled receptor, the Urotensin Receptor (UTR), initiating a cascade of intracellular events with significant implications for cardiovascular physiology and various pathological states. This document details the primary signaling axes, presents quantitative data from relevant studies, outlines key experimental protocols, and provides visual representations of the molecular pathways.

Core Signaling Pathways of Urotensin II in Mouse Cells

Urotensin II binding to its receptor (UTR), primarily coupled to Gαq/11, triggers several key downstream signaling cascades. While much of the detailed mechanistic work has been performed in various species, the fundamental pathways are considered to be conserved in mice.

Phospholipase C (PLC) / Inositol Trisphosphate (IP3) / Calcium (Ca²⁺) Pathway

Activation of the UTR by UII leads to the stimulation of Phospholipase C (PLC).[1] PLC hydrolyzes phosphatidylinositol 4,5-bisphosphate (PIP₂) into two second messengers: inositol 1,4,5-trisphosphate (IP₃) and diacylglycerol (DAG).[2] IP₃ diffuses through the cytoplasm and binds to its receptor on the endoplasmic reticulum, triggering the release of stored intracellular calcium (Ca²⁺).[2] This rapid increase in cytosolic Ca²⁺ concentration is a critical event that initiates numerous downstream cellular responses.

Mitogen-Activated Protein Kinase (MAPK) Pathways

UII is a potent activator of several MAPK pathways, which are crucial for regulating cell proliferation, differentiation, and hypertrophy.

- Extracellular signal-regulated kinases (ERK1/2): The UII-UTR system robustly activates the ERK1/2 pathway.[3][4] This activation can be dependent on the transactivation of the Epidermal Growth Factor Receptor (EGFR).[4] In some cellular contexts, this pathway is linked to cell proliferation and hypertrophy.[4][5]
- p38 MAPK: UII stimulation also leads to the phosphorylation and activation of p38 MAPK.[2][3] This pathway is often associated with cellular stress responses and inflammation.[6]
- c-Jun N-terminal Kinase (JNK): The involvement of the JNK pathway appears to be cell-type specific. While some studies in cardiac myocytes suggest UII does not activate JNK[2][4], others have shown JNK activation is critical for inhibiting the proliferation of cardiac side population cells in mice.[7]

RhoA/Rho-Kinase (ROCK) Pathway

In vascular smooth muscle and endothelial progenitor cells, UII activates the small GTPase RhoA and its downstream effector, Rho-kinase (ROCK).[8][9][10] This pathway is a major contributor to UII-induced vasoconstriction, cell migration, and actin stress fiber formation.[10]

Quantitative Data on Urotensin II Signaling

The following tables summarize key quantitative data from studies on Ull signaling. It is important to note that some data is derived from experiments using recombinant mouse receptors expressed in non-murine cell lines, a common practice in pharmacological studies.

Parameter	Cell Type	Species	Value	Reference
Receptor Binding				
Kd ([125I]hU-II)	HEK-293 expressing mouse UT receptor	Mouse (recombinant)	654 ± 154 pM	[11]
Bmax ([125I]hU-II)	HEK-293 expressing mouse UT receptor	Mouse (recombinant)	1011 ± 125 fmol/mg protein	[11]
Second Messenger Production				
EC50 (Intracellular Ca ²⁺ mobilization)	HEK-293 expressing mouse UT receptor	Mouse (recombinant)	3.2 ± 0.8 nM	[11]
EC50 (Inositol Phosphate formation)	HEK-293 expressing mouse UT receptor	Mouse (recombinant)	7.2 ± 1.8 nM	[11]
MAPK Activation (Time Course)				
Peak ERK1/2 Phosphorylation	Neonatal Cardiomyocytes (AdUT-IIR infected)	Rat	5-10 minutes	[3]
Peak p38 Phosphorylation	Neonatal Cardiomyocytes (AdUT-IIR infected)	Rat	5 minutes	[3]

Peak ERK1/2 Phosphorylation	Adult Ventricular Myocytes	Rat	7.5 minutes	[2][6]
-----------------------------	----------------------------	-----	-------------	--------

Signaling Pathway and Experimental Workflow Diagrams

The following diagrams were generated using Graphviz (DOT language) to visualize the core signaling pathways and a typical experimental workflow.

Urotensin II Signaling Pathways

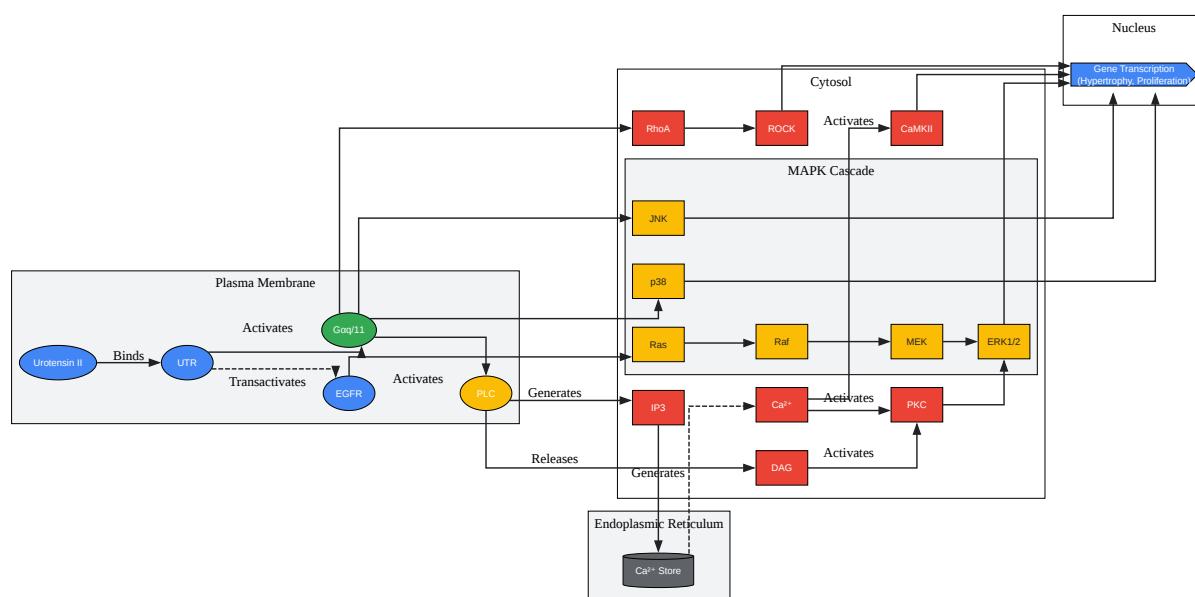

[Click to download full resolution via product page](#)

Core Urotensin II signaling pathways in mouse cells.

Experimental Workflow for Western Blotting of Phospho-ERK

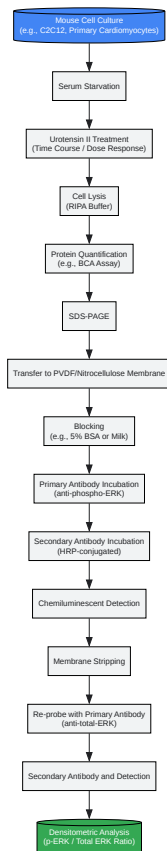

[Click to download full resolution via product page](#)

Workflow for analyzing ERK phosphorylation via Western Blot.

Detailed Experimental Protocols

Western Blotting for Phosphorylated ERK1/2

This protocol is adapted for the analysis of UII-induced ERK1/2 phosphorylation in cultured mouse cells.[\[12\]](#)

1. Cell Culture and Treatment:

- Plate mouse cells (e.g., C2C12 myoblasts, primary vascular smooth muscle cells) in 6-well plates and grow to 80-90% confluency.
- Serum-starve the cells for 12-24 hours to reduce basal ERK phosphorylation.
- Treat cells with desired concentrations of Urotensin II for various time points (e.g., 0, 5, 10, 15, 30, 60 minutes).

2. Cell Lysis:

- Aspirate the media and wash cells once with ice-cold Phosphate Buffered Saline (PBS).
- Add 100-150 μ L of ice-cold RIPA buffer containing protease and phosphatase inhibitors.
- Scrape the cells and transfer the lysate to a microcentrifuge tube.
- Incubate on ice for 30 minutes, vortexing occasionally.
- Centrifuge at 14,000 x g for 15 minutes at 4°C.
- Collect the supernatant containing the protein extract.

3. Protein Quantification:

- Determine the protein concentration of each lysate using a BCA or Bradford protein assay according to the manufacturer's instructions.

4. SDS-PAGE and Western Blotting:

- Normalize protein amounts for each sample (typically 20-30 μ g per lane) and prepare with Laemmli sample buffer.
- Resolve proteins on a 10% SDS-polyacrylamide gel.
- Transfer the separated proteins to a PVDF or nitrocellulose membrane.
- Block the membrane with 5% non-fat dry milk or Bovine Serum Albumin (BSA) in Tris-Buffered Saline with 0.1% Tween-20 (TBST) for 1 hour at room temperature.
- Incubate the membrane with a primary antibody specific for phosphorylated ERK1/2 (e.g., anti-phospho-p44/42 MAPK) overnight at 4°C, following the manufacturer's recommended dilution.
- Wash the membrane three times with TBST for 10 minutes each.

- Incubate with an appropriate HRP-conjugated secondary antibody for 1 hour at room temperature.
- Wash the membrane again as in the previous step.
- Visualize the protein bands using an enhanced chemiluminescence (ECL) detection system.

5. Stripping and Re-probing for Total ERK:

- To normalize for protein loading, strip the membrane of the phospho-ERK antibodies using a mild stripping buffer.
- Re-block the membrane and probe with a primary antibody for total ERK1/2.
- Repeat the secondary antibody and detection steps.

6. Data Analysis:

- Quantify the band intensities for both phosphorylated and total ERK using densitometry software.
- Calculate the ratio of phospho-ERK to total ERK for each sample to determine the relative activation of the pathway.

Intracellular Calcium Mobilization Assay

This protocol outlines the measurement of Ull-induced changes in intracellular calcium using a fluorescent indicator.[\[13\]](#)

1. Cell Preparation:

- Seed mouse cells onto glass-bottom dishes or 96-well black-walled plates suitable for fluorescence microscopy/plate reading.
- Grow cells to a confluent monolayer.

2. Fluorescent Dye Loading:

- Prepare a loading buffer (e.g., Hanks' Balanced Salt Solution with 20 mM HEPES).
- Load the cells with a calcium-sensitive fluorescent dye (e.g., 2-5 μ M Fura-2 AM or Fluo-4 AM) in loading buffer for 30-60 minutes at 37°C in the dark.
- Wash the cells twice with the loading buffer to remove excess dye.

3. Calcium Measurement:

- Place the dish/plate into a fluorescence imaging system or a plate reader equipped for kinetic reading.
- Establish a stable baseline fluorescence recording.
- Add Urotensin II at the desired concentration and continue to record the fluorescence signal over time.
- For ratiometric dyes like Fura-2, alternate excitation wavelengths (e.g., 340 nm and 380 nm) and measure emission at ~510 nm. The ratio of the emissions (F340/F380) is proportional to the intracellular calcium concentration.
- For single-wavelength dyes like Fluo-4, excite at ~490 nm and measure emission at ~520 nm. The change in fluorescence intensity (F/F₀) indicates the change in calcium levels.

4. Data Analysis:

- Quantify the change in fluorescence ratio or intensity from baseline to the peak response after UII addition.
- Dose-response curves can be generated by testing a range of UII concentrations to determine the EC₅₀.

This guide provides a foundational understanding of Urotensin II signaling in mouse cells, supported by quantitative data, visual diagrams, and actionable experimental protocols to aid researchers in this field.

Need Custom Synthesis?

BenchChem offers custom synthesis for rare earth carbides and specific isotopic labeling.

Email: info@benchchem.com or [Request Quote Online](#).

References

- [1. Urotensin-II receptor - Wikipedia \[en.wikipedia.org\]](#)
- [2. Signalling pathways involved in urotensin II induced ventricular myocyte hypertrophy - PMC \[pmc.ncbi.nlm.nih.gov\]](#)
- [3. academic.oup.com \[academic.oup.com\]](#)
- [4. Urotensin II promotes hypertrophy of cardiac myocytes via mitogen-activated protein kinases - PubMed \[pubmed.ncbi.nlm.nih.gov\]](#)

- 5. Urotensin II-induced activation of extracellular signal-regulated kinase in cultured vascular smooth muscle cells: involvement of cell adhesion-mediated integrin signaling - PubMed [pubmed.ncbi.nlm.nih.gov]
- 6. Signalling pathways involved in urotensin II induced ventricular myocyte hypertrophy | PLOS One [journals.plos.org]
- 7. Urotensin II inhibited the proliferation of cardiac side population cells in mice during pressure overload by JNK-LRP6 signalling - PMC [pmc.ncbi.nlm.nih.gov]
- 8. Urotensin II induces migration of endothelial progenitor cells via activation of the RhoA/Rho kinase pathway - PubMed [pubmed.ncbi.nlm.nih.gov]
- 9. spandidos-publications.com [spandidos-publications.com]
- 10. ahajournals.org [ahajournals.org]
- 11. faculty.uobasrah.edu.iq [faculty.uobasrah.edu.iq]
- 12. Activation of the ERK1/2 Mitogen-Activated Protein Kinase Cascade by Dentin Matrix Protein 1 Promotes Osteoblast Differentiation - PMC [pmc.ncbi.nlm.nih.gov]
- 13. State-dependent calcium mobilization by urotensin-II in cultured human endothelial cells - PubMed [pubmed.ncbi.nlm.nih.gov]
- To cite this document: BenchChem. [Urotensin II Signaling in Mouse Cells: An In-depth Technical Guide]. BenchChem, [2026]. [Online PDF]. Available at: [<https://www.benchchem.com/product/b15602724/docs#urotensin-ii-signaling-in-mouse-cells-an-in-depth-technical-guide>]

Disclaimer & Data Validity:

The information provided in this document is for Research Use Only (RUO) and is strictly not intended for diagnostic or therapeutic procedures. While BenchChem strives to provide accurate protocols, we make no warranties, express or implied, regarding the fitness of this product for every specific experimental setup.

Technical Support: The protocols provided are for reference purposes. Unsure if this reagent suits your experiment?

Need Industrial/Bulk Grade? [Request Custom Synthesis Quote](#)

BenchChem

Our mission is to be the trusted global source of essential and advanced chemicals, empowering scientists and researchers to drive progress in science and industry.

Contact

Address: 3281 E Guasti Rd

Ontario, CA 91761, United States

Phone: (601) 213-4426

Email: info@benchchem.com

[Contact our Ph.D. Support Team for a compatibility check](#)