

Technical Support Center: Optimizing T Cell Activation with OX86 Antibody

Author: BenchChem Technical Support Team. **Date:** April 2026

Compound of Interest

Compound Name: Anti-Mouse OX40/CD134 (LALA-PG) Antibody (OX86)

Cat. No.: B15602332

[Get Quote](#)

This technical support center provides troubleshooting guides and frequently asked questions (FAQs) to assist researchers, scientists, and drug development professionals in the successful titration of the OX86 antibody for optimal in vitro T cell activation.

Frequently Asked Questions (FAQs)

Q1: What is the primary mechanism of action for the OX86 antibody in T cell activation?

A1: The OX86 antibody is an agonistic monoclonal antibody that targets the mouse OX40 (CD134) receptor, a member of the tumor necrosis factor (TNF) receptor superfamily.[1] OX40 is transiently expressed on activated CD4+ and CD8+ T cells.[2] By binding to and stimulating OX40, the OX86 antibody provides a co-stimulatory signal to T cells. This enhances clonal expansion, proliferation, survival, and cytokine production, ultimately leading to a more robust immune response.[1][3][4]

Q2: What is the typical starting concentration range for titrating the OX86 antibody for in vitro T cell activation?

A2: The optimal concentration of OX86 should be empirically determined for each specific cell type and experimental condition. However, a common starting point for titration of activating antibodies is in the range of 0.1 µg/mL to 10 µg/mL.[5][6] For initial experiments, it is advisable to test a broad range of concentrations, for example, using serial dilutions.

Q3: How should I assess the optimal concentration of OX86 in my titration experiment?

A3: The optimal concentration is the one that provides the maximal desired biological response with minimal non-specific effects. This can be assessed by measuring several key readouts of T cell activation:

- Proliferation: Measured by assays such as CFSE or CellTrace Violet dilution, or incorporation of BrdU or ³H-thymidine.[7][8]
- Expression of Activation Markers: Assessed by flow cytometry for markers like CD25 and CD69.[9][10]
- Cytokine Production: Quantification of cytokines such as IFN-γ and IL-2 in the culture supernatant by ELISA or intracellular cytokine staining followed by flow cytometry.[1][4]

Q4: Can I use the OX86 antibody alone to activate T cells in vitro?

A4: While OX86 provides a potent co-stimulatory signal, T cell activation generally requires a primary signal through the T cell receptor (TCR). Therefore, OX86 is most effective when used in combination with a primary TCR stimulus, such as anti-CD3 and anti-CD28 antibodies.[5][10]

Q5: What is the recommended cell density for in vitro T cell activation assays with OX86?

A5: The optimal cell density can vary, but a common starting point for T cell activation in a 96-well plate is 1 x 10⁵ to 2 x 10⁵ cells per well.[5][8] It is recommended to perform a cell density titration in your specific experimental setup.[5]

Troubleshooting Guide

Issue	Possible Cause(s)	Recommended Solution(s)
Suboptimal or No T Cell Activation	Incorrect OX86 Concentration: The concentration of the OX86 antibody may be too low to elicit a strong co-stimulatory signal.	Perform a dose-response experiment by titrating the OX86 antibody over a wider range of concentrations (e.g., 0.01 µg/mL to 20 µg/mL). [11] [12]
Insufficient Primary Stimulation: The primary TCR stimulation (e.g., anti-CD3/anti-CD28) may be suboptimal.	Titrate the anti-CD3 and anti-CD28 antibodies to find the optimal concentration for your specific T cell population. [5] [7]	
Poor Cell Health: The T cells may have low viability before or during the experiment.	Ensure proper handling and isolation of T cells. Use freshly isolated cells whenever possible and check viability before starting the experiment.	
Inadequate Incubation Time: The duration of the culture may not be sufficient for T cell activation to become apparent.	Perform a time-course experiment, analyzing T cell activation at different time points (e.g., 24, 48, 72, and 96 hours). [5]	
High Background or Non-Specific Activation	Excessive OX86 Concentration: Too high a concentration of the OX86 antibody can lead to non-specific binding and activation.	Titrate the OX86 antibody to lower concentrations to find the optimal signal-to-noise ratio. [11] [13]
Contamination: Mycoplasma or endotoxin contamination in cell cultures or reagents can cause non-specific immune cell activation.	Use certified sterile and endotoxin-free reagents and practice good aseptic technique. Regularly test cell lines for mycoplasma.	
High Cell Death	Activation-Induced Cell Death (AICD): Prolonged or	Optimize the concentration of activating antibodies (anti-CD3, anti-CD28, and OX86)

	excessive stimulation can lead to AICD.	and the duration of the stimulation.[5]
Suboptimal Culture Conditions: Inappropriate media, serum, or incubator conditions can lead to cell death.	Ensure the use of appropriate, high-quality culture media and supplements, and maintain optimal incubator conditions (37°C, 5% CO ₂).	
Inconsistent Results	Variability in Reagents: Different lots of antibodies or media can have varying potency.	Use the same lot of critical reagents throughout a series of experiments. If a new lot is introduced, perform a bridging experiment to ensure consistency.
Pipetting Errors: Inaccurate pipetting can lead to significant variability in antibody concentrations.	Use calibrated pipettes and proper pipetting techniques. For small volumes, consider preparing a master mix.[12]	
Donor-to-Donor Variability: Primary T cells from different donors can exhibit significant variability in their response to stimulation.	Whenever possible, use T cells from the same donor for a set of comparative experiments. If using multiple donors, analyze the data on a per-donor basis.	

Data Presentation

Table 1: Example Titration of OX86 Antibody for T Cell Proliferation

OX86 Conc. (µg/mL)	% Proliferating CD4+ T Cells (CFSE Low)	% Proliferating CD8+ T Cells (CFSE Low)
0 (Control)	5.2 ± 1.1	3.8 ± 0.9
0.1	25.6 ± 3.5	21.4 ± 2.8
0.5	58.9 ± 5.2	52.1 ± 4.7
1.0	75.3 ± 6.1	68.9 ± 5.5
5.0	78.1 ± 5.8	72.3 ± 6.0
10.0	76.5 ± 6.3	70.1 ± 5.9

Data are representative and presented as mean ± standard deviation. Optimal concentration should be determined experimentally.

Table 2: Example Titration of OX86 Antibody for IFN-γ Production

OX86 Conc. (µg/mL)	IFN-γ Concentration (pg/mL) in Supernatant
0 (Control)	50 ± 15
0.1	350 ± 45
0.5	1200 ± 110
1.0	2500 ± 230
5.0	2650 ± 250
10.0	2580 ± 240

Data are representative and presented as mean ± standard deviation. Optimal concentration should be determined experimentally.

Experimental Protocols

Protocol 1: In Vitro T Cell Activation and Proliferation Assay

Materials:

- Isolated mouse T cells (CD4+ or CD8+)
- Complete RPMI-1640 medium (supplemented with 10% FBS, 2 mM L-glutamine, 100 U/mL penicillin, and 100 µg/mL streptomycin)
- Anti-mouse CD3e antibody (clone 145-2C11)
- Anti-mouse CD28 antibody (clone 37.51)
- OX86 antibody
- CFSE (Carboxyfluorescein succinimidyl ester) or other proliferation dye
- 96-well flat-bottom culture plates
- Flow cytometer

Procedure:

- Plate Coating (for anti-CD3): a. Dilute anti-mouse CD3e antibody to a final concentration of 1-5 µg/mL in sterile PBS. b. Add 50 µL of the antibody solution to each well of a 96-well plate. c. Incubate the plate for 2-4 hours at 37°C or overnight at 4°C. d. Before use, wash the wells twice with 200 µL of sterile PBS to remove unbound antibody.
- T Cell Staining with Proliferation Dye: a. Resuspend isolated T cells at 1×10^6 cells/mL in pre-warmed PBS. b. Add CFSE to a final concentration of 1-5 µM and incubate for 10-15 minutes at 37°C, protected from light. c. Quench the staining by adding 5 volumes of ice-cold complete RPMI medium. d. Wash the cells twice with complete RPMI medium.
- Cell Seeding and Stimulation: a. Resuspend the CFSE-labeled T cells in complete RPMI medium at a concentration of 1×10^6 cells/mL. b. Add 100 µL of the cell suspension (1×10^5 cells) to each well of the anti-CD3 coated plate. c. Prepare serial dilutions of the OX86

antibody and soluble anti-mouse CD28 antibody (final concentration of 1-2 $\mu\text{g}/\text{mL}$) in complete RPMI medium. d. Add 100 μL of the antibody dilutions to the respective wells. The final volume in each well should be 200 μL .

- Incubation: a. Incubate the plate for 72-96 hours at 37°C in a humidified 5% CO₂ incubator.
- Flow Cytometry Analysis: a. Harvest the cells from each well. b. Stain the cells with fluorescently labeled antibodies against surface markers (e.g., CD4, CD8) and a viability dye. c. Analyze the samples on a flow cytometer. Proliferation is measured by the dilution of the CFSE signal.

Visualizations

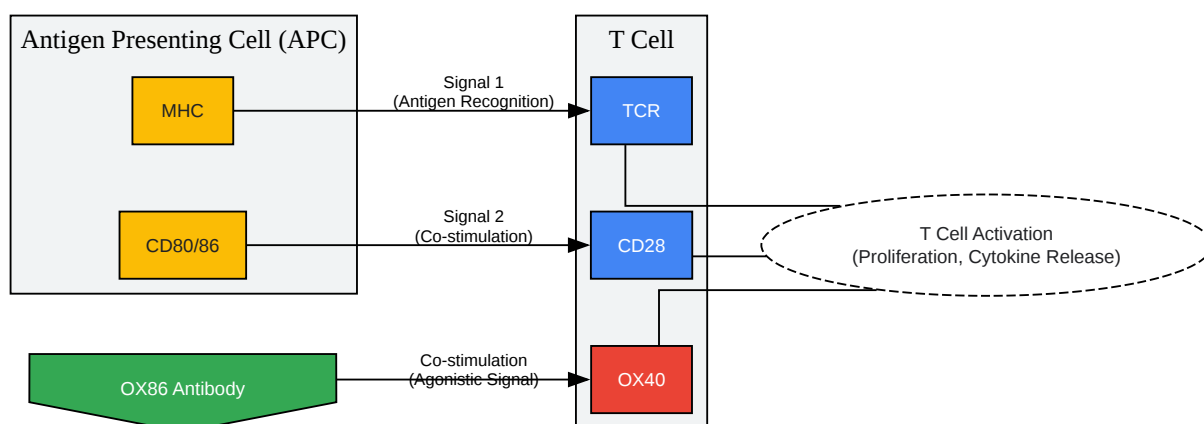

[Click to download full resolution via product page](#)

Caption: OX86 antibody-mediated T cell activation pathway.

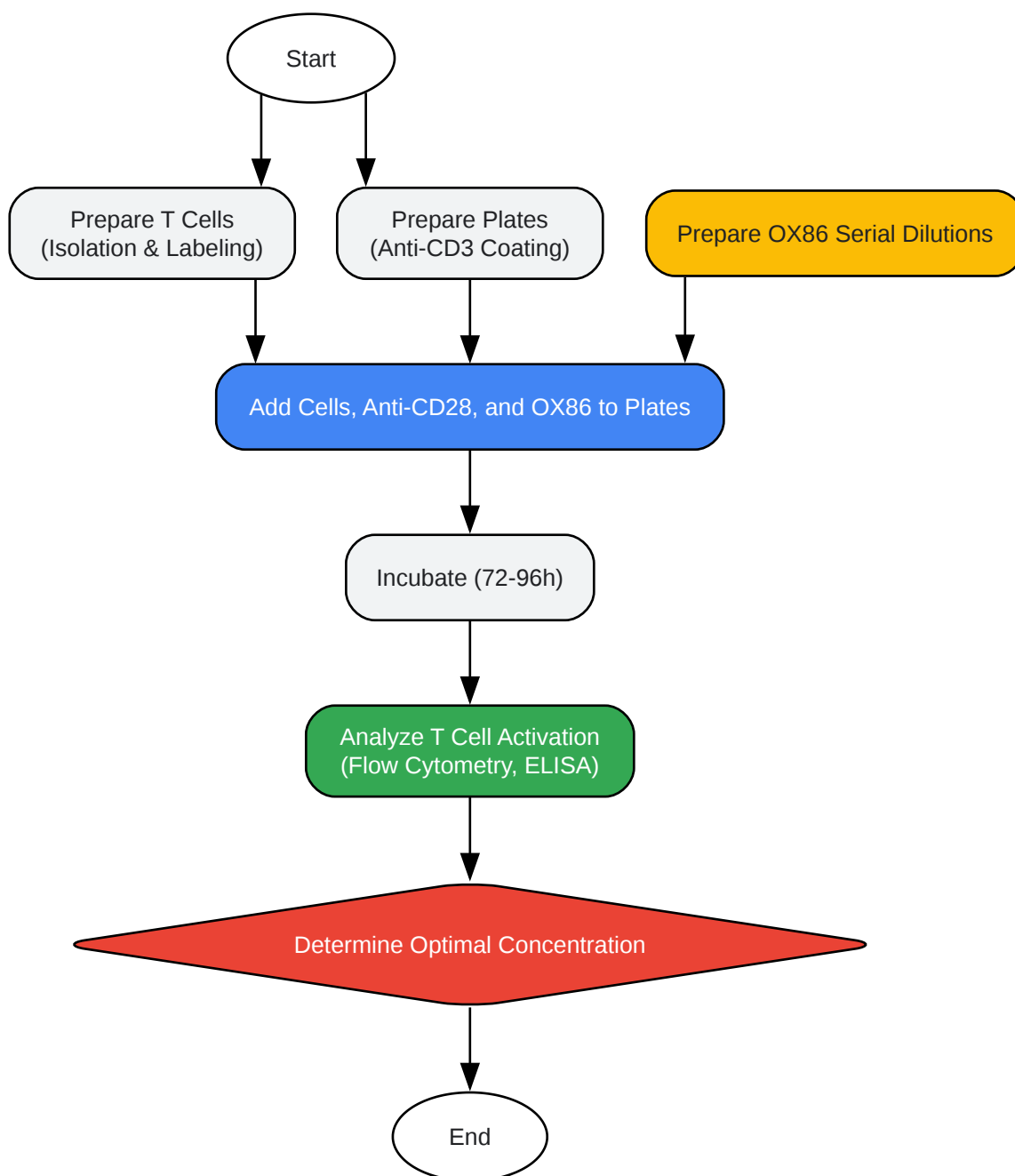

[Click to download full resolution via product page](#)

Caption: Experimental workflow for OX86 antibody titration.

Need Custom Synthesis?

BenchChem offers custom synthesis for rare earth carbides and specific isotopic labeling.

Email: info@benchchem.com or [Request Quote Online](#).

References

- [1. Anti-Mouse CD134 \(Clone OX86\) – Purified In Vivo | Leinco \[leinco.com\]](#)
- [2. assaygenie.com \[assaygenie.com\]](#)
- [3. OX40 Monoclonal Antibody \(OX86\) \(MA1-70087\) \[thermofisher.com\]](#)
- [4. Anti-Mouse CD134 \(Clone OX86\) Purified In Vivo PLATINUM™ \[leinco.com\]](#)
- [5. tools.thermofisher.com \[tools.thermofisher.com\]](#)
- [6. researchgate.net \[researchgate.net\]](#)
- [7. agilent.com \[agilent.com\]](#)
- [8. benchchem.com \[benchchem.com\]](#)
- [9. medrxiv.org \[medrxiv.org\]](#)
- [10. In vitro assays for effector T cell functions and activity of immunomodulatory antibodies - PMC \[pmc.ncbi.nlm.nih.gov\]](#)
- [11. cancer.wisc.edu \[cancer.wisc.edu\]](#)
- [12. umt.edu \[umt.edu\]](#)
- [13. colibri-cytometry.com \[colibri-cytometry.com\]](#)
- To cite this document: BenchChem. [Technical Support Center: Optimizing T Cell Activation with OX86 Antibody]. BenchChem, [2026]. [Online PDF]. Available at: [\[https://www.benchchem.com/product/b15602332/docs#technical-support-center-optimizing-t-cell-activation-with-ox86-antibody\]](https://www.benchchem.com/product/b15602332/docs#technical-support-center-optimizing-t-cell-activation-with-ox86-antibody)

Disclaimer & Data Validity:

The information provided in this document is for Research Use Only (RUO) and is strictly not intended for diagnostic or therapeutic procedures. While BenchChem strives to provide accurate protocols, we make no warranties, express or implied, regarding the fitness of this product for every specific experimental setup.

Technical Support: The protocols provided are for reference purposes. Unsure if this reagent suits your experiment?

Need Industrial/Bulk Grade? [Request Custom Synthesis Quote](#)

BenchChem

Our mission is to be the trusted global source of essential and advanced chemicals, empowering scientists and researchers to drive progress in science and industry.

Contact

Address: 3281 E Guasti Rd

Ontario, CA 91761, United States

Phone: (601) 213-4426

Email: info@benchchem.com

[Contact our Ph.D. Support Team for a compatibility check](#)