

Technical Support Center: Addressing Toxicity of Combination Checkpoint Inhibitor Therapy

Author: BenchChem Technical Support Team. **Date:** April 2026

Compound of Interest

Compound Name: *dPDL1-4*
Cat. No.: *B15602809*

[Get Quote](#)

This technical support center provides troubleshooting guides and frequently asked questions (FAQs) for researchers, scientists, and drug development professionals investigating the toxicity of combination checkpoint inhibitor therapies. The information is presented in a question-and-answer format to directly address specific issues that may be encountered during preclinical experiments.

Frequently Asked Questions (FAQs)

Q1: What are the most common immune-related adverse events (irAEs) observed in preclinical mouse models of combination checkpoint inhibitor therapy?

A1: In preclinical mouse models, particularly those using dual blockade of CTLA-4 and PD-1, the most frequently observed irAEs mirror those seen in clinical settings. These include, but are not limited to, colitis, hepatitis, dermatitis, pneumonitis, and endocrinopathies such as hypophysitis.[1][2] The specific incidence and severity of these irAEs can vary depending on the mouse strain, the tumor model used, and the specific antibody clones and dosing regimens.[1]

Q2: We are observing significant weight loss in our treatment group that is not correlated with tumor burden. What could be the cause and how should we proceed?

A2: Significant weight loss independent of tumor size is a common clinical sign of systemic toxicity and potential irAEs in mouse models of checkpoint inhibitor therapy.^[1] This can be a manifestation of colitis, hepatitis, or a more generalized inflammatory syndrome.

Recommended Actions:

- Increase Monitoring: Monitor the mice daily for clinical signs of distress, including hunched posture, ruffled fur, and lethargy, in addition to body weight.
- Investigate Specific irAEs:
 - Colitis: Check for signs of diarrhea and consider collecting fecal samples for analysis of inflammatory markers.
 - Hepatitis: Collect blood samples to measure serum levels of liver enzymes such as alanine aminotransferase (ALT) and aspartate aminotransferase (AST).
- Necropsy and Histopathology: At the experimental endpoint, or if humane endpoints are reached, perform a thorough necropsy. Collect organs, particularly the colon, liver, and lungs, for histopathological analysis to assess for immune cell infiltration and tissue damage.^{[1][3]}

Q3: Our in vitro co-culture of T cells and tumor cells with combination checkpoint inhibitors shows widespread, non-specific cell death. How can we troubleshoot this?

A3: Widespread cell death in an in vitro co-culture could be due to several factors unrelated to the specific on-target effect of the checkpoint inhibitors.

Troubleshooting Steps:

- Titrate Antibody Concentrations: The concentrations of the anti-CTLA-4 and anti-PD-1 antibodies may be too high, leading to over-stimulation of T cells and subsequent activation-induced cell death (AICD). Perform a dose-response experiment to determine the optimal concentration of each antibody.
- Check for Endotoxin Contamination: Endotoxins in reagents can cause non-specific immune cell activation and toxicity. Use endotoxin-free reagents and test your antibody preparations for endotoxin levels.

- **Optimize Cell Seeding Density:** An inappropriate ratio of T cells to tumor cells can lead to rapid nutrient depletion and accumulation of toxic metabolites in the culture medium. Optimize the effector-to-target ratio.
- **Include Appropriate Controls:** Ensure you have the following controls:
 - T cells alone (with and without antibodies)
 - Tumor cells alone (with and without antibodies)
 - Isotype control antibodies to rule out non-specific antibody effects.

Troubleshooting Guides

In Vivo Study: Unexpected Toxicity

Issue: Mice treated with combination anti-CTLA-4 and anti-PD-1 antibodies are showing severe, unexpected toxicity (e.g., rapid weight loss, mortality) early in the study.

Possible Cause	Suggested Solution
Dose Too High	The dosing regimen may be too aggressive for the specific mouse strain. Reduce the dose of one or both antibodies or decrease the frequency of administration.
Mouse Strain Susceptibility	Some mouse strains are more prone to developing autoimmunity and irAEs.[1] Consider using a different, less susceptible strain or ensure the current strain is appropriate for your study goals.
Cytokine Release Syndrome (CRS)	The rapid activation of T cells can lead to a systemic inflammatory response. Measure serum cytokine levels (e.g., IFN- γ , TNF- α , IL-6) to assess for CRS.[4][5] Consider prophylactic or therapeutic intervention with agents that block key inflammatory cytokines if this aligns with your experimental questions.
Off-Target Antibody Effects	Ensure the antibodies are specific and of high purity. Use appropriate isotype controls to confirm that the observed toxicity is specific to checkpoint blockade.

Assay-Specific Troubleshooting: Cytokine ELISA

Issue: High background or low signal-to-noise ratio in your cytokine ELISA.

Possible Cause	Suggested Solution
Improper Washing	Insufficient washing between steps can leave unbound reagents, leading to high background. Increase the number of wash steps and ensure complete removal of wash buffer between each step.
Incorrect Antibody Concentrations	Suboptimal concentrations of capture or detection antibodies can lead to a poor signal. Titrate both antibodies to determine the optimal concentrations for your assay.
Substrate Incubation Time	The incubation time with the TMB substrate may be too long (high background) or too short (low signal). Optimize the incubation time based on the manufacturer's recommendations and your specific experimental conditions.
Sample Matrix Effects	Components in the serum or plasma, such as lipids or heterophilic antibodies, can interfere with the assay. Use the recommended sample diluent provided in the ELISA kit and consider further dilution of your samples.

Quantitative Data Summary

The following tables provide a summary of quantitative data that can be expected in preclinical models of combination checkpoint inhibitor toxicity. Note that these values can vary significantly between different experimental systems.

Table 1: Common Incidence of Grade 3/4 irAEs in Patients Treated with Combination Ipilimumab and Nivolumab

Adverse Event	Incidence (%)
Colitis/Diarrhea	~50%
Transaminitis	~50%
Dermatitis	~50%

Data derived from clinical trial information and may not directly reflect preclinical model incidence.[6]

Table 2: Typical Assay Ranges for Mouse Cytokine ELISAs

Cytokine	Typical Assay Range (pg/mL)
TNF- α	10.9 - 700
IFN- γ	62.5 - 2000
IL-6	31.25 - 1000
IL-1 β	31.25 - 1000

These ranges are based on commercially available ELISA kits and may vary.[7]

Experimental Protocols

Protocol 1: ELISA for Mouse Cytokines (TNF- α , IFN- γ , IL-6)

Objective: To quantify the concentration of pro-inflammatory cytokines in mouse serum.

Materials:

- Commercially available mouse TNF- α , IFN- γ , or IL-6 ELISA kit (e.g., from R&D Systems, BD Biosciences, or STEMCELL Technologies).
- Mouse serum samples.
- Microplate reader capable of measuring absorbance at 450 nm.

Methodology:

- **Reagent Preparation:** Prepare all reagents, standards, and samples as described in the ELISA kit manual. Bring all reagents to room temperature before use.
- **Plate Coating (if applicable):** Coat the wells of a 96-well microplate with the capture antibody overnight at 4°C.
- **Blocking:** Wash the plate and block non-specific binding sites with the provided blocking buffer for 1-2 hours at room temperature.
- **Standard and Sample Incubation:** Wash the plate. Add serially diluted standards and your serum samples to the wells. Incubate for 2 hours at room temperature.
- **Detection Antibody Incubation:** Wash the plate. Add the biotinylated detection antibody to each well and incubate for 1-2 hours at room temperature.
- **Streptavidin-HRP Incubation:** Wash the plate. Add streptavidin-horseradish peroxidase (HRP) conjugate and incubate for 20-30 minutes at room temperature in the dark.
- **Substrate Development:** Wash the plate. Add TMB substrate and incubate for 15-30 minutes at room temperature in the dark, or until a color change is observed.
- **Stop Reaction:** Add the stop solution to each well. The color will change from blue to yellow.
- **Read Plate:** Measure the absorbance at 450 nm within 30 minutes of adding the stop solution.
- **Data Analysis:** Generate a standard curve by plotting the absorbance of the standards against their known concentrations. Use the standard curve to determine the concentration of the cytokine in your samples.

Protocol 2: Hematoxylin and Eosin (H&E) Staining for Inflammation in Mouse Colon

Objective: To visualize and score immune cell infiltration and tissue damage in the colon.

Materials:

- Formalin-fixed, paraffin-embedded (FFPE) mouse colon tissue sections (5 μ m).
- Xylene, ethanol (100%, 95%, 70%).
- Hematoxylin and eosin stains.
- Microscope.

Methodology:

- Deparaffinization and Rehydration:
 - Immerse slides in xylene (2 changes, 5 minutes each).
 - Immerse in 100% ethanol (2 changes, 3 minutes each).
 - Immerse in 95% ethanol (1 change, 3 minutes).
 - Immerse in 70% ethanol (1 change, 3 minutes).
 - Rinse in running tap water.
- Hematoxylin Staining:
 - Immerse in hematoxylin for 3-5 minutes.
 - Rinse in running tap water.
 - "Blue" the sections in Scott's tap water substitute or dilute ammonia water for 30-60 seconds.
 - Rinse in running tap water.
- Eosin Staining:
 - Immerse in 95% ethanol for 1-2 minutes.

- Immerse in eosin for 1-3 minutes.
- Dehydration and Clearing:
 - Immerse in 95% ethanol (2 changes, 1 minute each).
 - Immerse in 100% ethanol (2 changes, 1 minute each).
 - Immerse in xylene (2 changes, 2 minutes each).
- Mounting: Apply a coverslip with mounting medium.
- Analysis: Examine the slides under a microscope. Score for inflammation based on the extent and severity of immune cell infiltrates, epithelial hyperplasia, goblet cell loss, and crypt abscesses.[8][9]

Protocol 3: Flow Cytometry for Quantification of Immune Cell Infiltration in Mouse Liver

Objective: To quantify the proportions of different immune cell subsets (e.g., T cells, macrophages) in the liver.

Materials:

- Freshly harvested mouse liver tissue.
- Collagenase D, DNase I.
- FACS buffer (PBS with 2% FBS).
- Fluorochrome-conjugated antibodies against immune cell surface markers (e.g., CD45, CD3, CD4, CD8, F4/80, CD11b).
- Flow cytometer.

Methodology:

- Tissue Dissociation:

- Perfuse the liver with PBS to remove blood.
- Mince the liver tissue and digest with collagenase D and DNase I at 37°C for 30-45 minutes with gentle agitation.
- Pass the cell suspension through a 70 µm cell strainer to obtain a single-cell suspension.
- Leukocyte Isolation:
 - Resuspend the cells in PBS and perform a Percoll gradient centrifugation to enrich for leukocytes.
 - Carefully collect the leukocyte layer.
- Cell Staining:
 - Wash the cells with FACS buffer.
 - Block Fc receptors with an anti-CD16/32 antibody.
 - Incubate the cells with a cocktail of fluorochrome-conjugated antibodies against your markers of interest for 30 minutes on ice in the dark.
- Data Acquisition:
 - Wash the cells and resuspend in FACS buffer.
 - Acquire data on a flow cytometer.
- Data Analysis:
 - Gate on live, single cells.
 - Identify the CD45+ leukocyte population.
 - Within the CD45+ gate, further delineate cell populations based on their specific marker expression (e.g., CD3+ for T cells, F4/80+CD11b+ for macrophages).

Visualizations

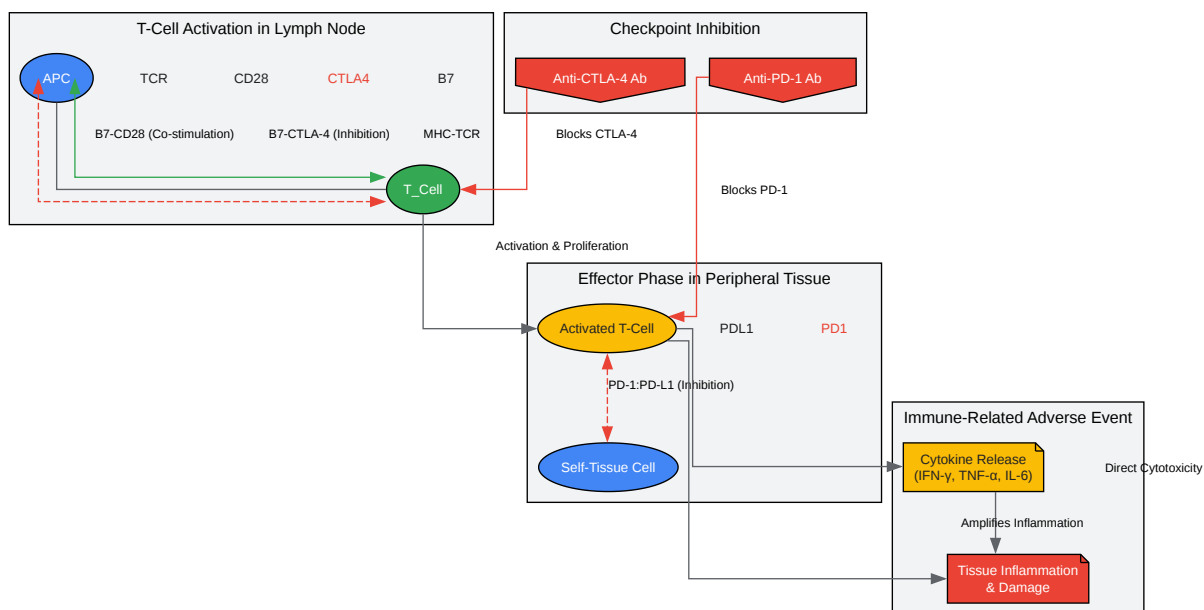

[Click to download full resolution via product page](#)

Caption: Signaling pathway of combination checkpoint inhibitor-induced toxicity.

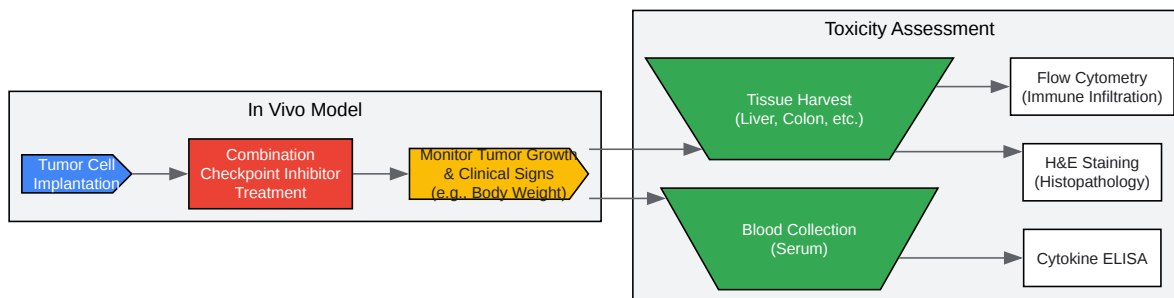

[Click to download full resolution via product page](#)

Caption: Experimental workflow for assessing combination checkpoint inhibitor toxicity.

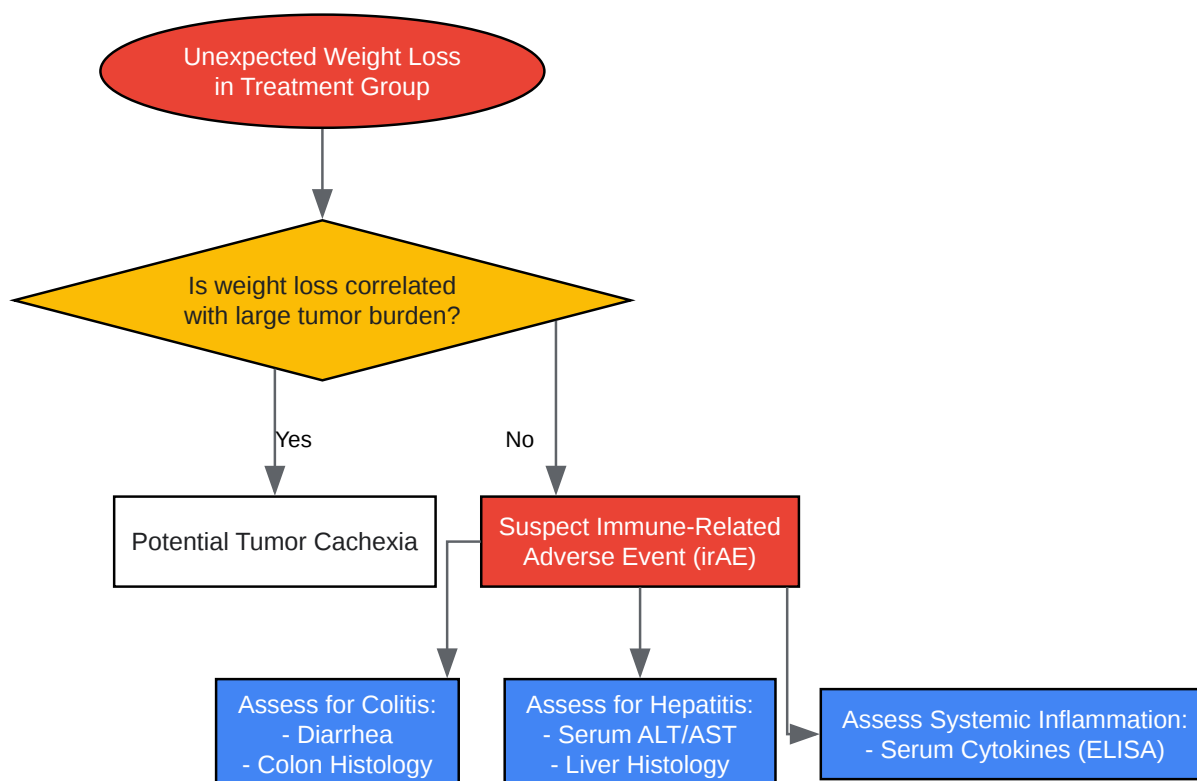

[Click to download full resolution via product page](#)

Caption: Troubleshooting flowchart for unexpected weight loss in in vivo studies.

Need Custom Synthesis?

BenchChem offers custom synthesis for rare earth carbides and specific isotopic labeling.

Email: info@benchchem.com or [Request Quote Online](#).

References

- 1. A novel mouse model for checkpoint inhibitor-induced adverse events - PMC [[pmc.ncbi.nlm.nih.gov](https://pubmed.ncbi.nlm.nih.gov/)]
- 2. Management of Immune Checkpoint Inhibitor Toxicities - PMC [[pmc.ncbi.nlm.nih.gov](https://pubmed.ncbi.nlm.nih.gov/)]
- 3. Establishment of an animal model of immune-related adverse events induced by immune checkpoint inhibitors - PMC [[pmc.ncbi.nlm.nih.gov](https://pubmed.ncbi.nlm.nih.gov/)]
- 4. Cytokine release syndrome: grading, modeling, and new therapy - PMC [[pmc.ncbi.nlm.nih.gov](https://pubmed.ncbi.nlm.nih.gov/)]
- 5. Early induction of cytokine release syndrome by rapidly generated CAR T cells in preclinical models - PMC [[pmc.ncbi.nlm.nih.gov](https://pubmed.ncbi.nlm.nih.gov/)]
- 6. aacrjournals.org [aacrjournals.org]
- 7. arigobio.com [arigobio.com]
- 8. A guide to histomorphological evaluation of intestinal inflammation in mouse models - PMC [[pmc.ncbi.nlm.nih.gov](https://pubmed.ncbi.nlm.nih.gov/)]
- 9. researchgate.net [researchgate.net]
- To cite this document: BenchChem. [Technical Support Center: Addressing Toxicity of Combination Checkpoint Inhibitor Therapy]. BenchChem, [2026]. [Online PDF]. Available at: [<https://www.benchchem.com/product/b15602809/docs#technical-support-center-addressing-toxicity-of-combination-checkpoint-inhibitor-therapy>]

Disclaimer & Data Validity:

The information provided in this document is for Research Use Only (RUO) and is strictly not intended for diagnostic or therapeutic procedures. While BenchChem strives to provide accurate protocols, we make no warranties, express or implied, regarding the fitness of this product for every specific experimental setup.

Technical Support: The protocols provided are for reference purposes. Unsure if this reagent suits your experiment?

Need Industrial/Bulk Grade? [Request Custom Synthesis Quote](#)

BenchChem

Our mission is to be the trusted global source of essential and advanced chemicals, empowering scientists and researchers to drive progress in science and industry.

Contact

Address: 3281 E Guasti Rd

Ontario, CA 91761, United States

Phone: (601) 213-4426

Email: info@benchchem.com

[Contact our Ph.D. Support Team for a compatibility check](#)