

Optimal Treatment Duration for PI4KIII Beta Inhibitors: Application Notes and Protocols

Author: BenchChem Technical Support Team. **Date:** April 2026

Compound of Interest

Compound Name: PI4KIII beta inhibitor 4

Cat. No.: B15602817

[Get Quote](#)

For Researchers, Scientists, and Drug Development Professionals

This document provides detailed application notes and protocols for determining the optimal treatment duration of Phosphatidylinositol 4-kinase III beta (PI4KIII β) inhibitors in various experimental settings. The information compiled is based on a review of in vitro and in vivo studies, offering guidance for research in virology, oncology, and cell biology.

Introduction

Phosphatidylinositol 4-kinase III beta (PI4KIII β) is a crucial enzyme in the phosphoinositide signaling pathway, catalyzing the production of phosphatidylinositol 4-phosphate (PI4P).[1][2][3] This lipid product plays a significant role in membrane trafficking and the formation of replication organelles for several RNA viruses, making PI4KIII β a compelling target for antiviral therapies.[2][3] Additionally, its involvement in signaling pathways like PI3K/Akt has implicated it in cancer progression.[4] The optimal duration of inhibitor treatment is critical for achieving desired experimental outcomes while minimizing off-target effects and potential cytotoxicity.

Data Presentation: Summary of Treatment Durations

The effective duration of PI4KIII β inhibitor treatment varies significantly depending on the experimental system and the specific endpoint being measured. The following tables summarize quantitative data from various studies.

Table 1: In Vitro Enzyme Inhibition Assays

Inhibitor Name/ID	Assay Type	Incubation Time	Key Findings
BF738735	In vitro kinase assay ([γ -33P]ATP)	75-90 minutes	IC50 of 5.7 nM against PI4KIII β . [5]
Various	ADP-Glo kinase assay	1.5 hours	Characterization of novel selective PI4KIII β inhibitors. [6]
PIK-93	In vitro kinase assay	Not Specified	IC50 of 19 nM against PI4KIII β . [1]

Table 2: Cell-Based Assays - Antiviral Activity

Inhibitor Name/ID	Cell Line	Virus	Treatment Duration	Key Findings
Bithiazole inhibitors	Calu-3	SARS-CoV-2	72 hours	Inhibition of viral replication. [7]
BF738735	HeLa	Human Rhinovirus 14	2-3 days	EC50 of 31 nM. [5]
BF738735	Various	Enteroviruses, Rhinoviruses	3-4 days	Broad-spectrum antiviral activity with EC50 values from 4 to 71 nM. [5]
BQR-695	MRC-5	Human Coronavirus	24 hours	Significant diminishment of viral replication. [8]

Table 3: Cell-Based Assays - Anticancer and Cellular Function Studies

Inhibitor Name/ID	Cell Line	Assay Type	Treatment Duration	Key Findings
IN-9	Lung adenocarcinoma cells	Proliferation (WST-1)	4 days	Dose-dependent inhibition of cell proliferation.[9]
IN-9	Lung adenocarcinoma cells	Colony Formation	7 days	Reduction in colony formation. [9]
IN-9	Lung adenocarcinoma cells	Migration/Invasion	16 hours	Inhibition of cell migration and invasion.[9]
IN-9	Lung adenocarcinoma cells	Apoptosis (Annexin V)	24 hours	Induction of apoptosis.[9]
Geldanamycin (Hsp90 inhibitor affecting PI4KII β stability)	HeLa	Protein stability	1-24 hours	Time-dependent loss of PI4KII β . [10][11]

Table 4: In Vivo Studies

Inhibitor Name/ID	Animal Model	Treatment Duration	Key Findings
Unnamed PI4KIII β inhibitor	Rats	4 days	Reduced T-cell-mediated B-cell activation and antibody formation.[7] [12]
Compound A (IN-9 analog)	Nude mice (orthotopic lung tumors)	7 days	Reduced primary tumor size and fewer metastases.[9]
F1 (PI4KA inhibitor)	Mice	14 days	Toxicity study to evaluate adverse effects.[6]

Experimental Protocols

Protocol 1: In Vitro PI4KIII β Kinase Activity Assay

This protocol is adapted from methods used to characterize inhibitors like BF738735.[5]

Objective: To determine the direct inhibitory effect of a compound on PI4KIII β enzymatic activity.

Materials:

- Recombinant PI4KIII β enzyme
- Substrate: Phosphatidylinositol (PI) and Phosphatidylserine (PS) vesicles
- Assay Buffer: Tris-HCl buffer with Triton X-100
- [γ -33P]ATP or [γ -32P]ATP
- ATP solution
- Test inhibitor (e.g., **PI4KIII beta inhibitor 4**)

- Phosphoric acid (to terminate the reaction)
- Scintillation counter

Procedure:

- Dilute the recombinant PI4KIII β enzyme and the PI/PS substrate in the assay buffer.
- Add the test inhibitor at various concentrations to the enzyme/substrate mixture.
- Pre-incubate for 10 minutes at 30°C.
- Initiate the kinase reaction by adding a mixture of ATP and [γ -³³P]ATP.
- Incubate the reaction mixture for 75-90 minutes at 30°C.
- Terminate the reaction by adding phosphoric acid.
- Measure the incorporated radioactivity using a scintillation counter to quantify PI4P production.
- Calculate the percent inhibition relative to a vehicle control (e.g., DMSO) and determine the IC₅₀ value.

Protocol 2: Antiviral Replication Assay

This protocol is a general method based on studies of various RNA viruses.[\[5\]](#)[\[7\]](#)

Objective: To assess the effect of a PI4KIII β inhibitor on viral replication in a cell-based assay.

Materials:

- Host cell line permissive to the virus of interest (e.g., HeLa, Calu-3)
- Virus stock
- Cell culture medium and supplements
- Test inhibitor

- Method for quantifying viral replication (e.g., plaque assay, RT-qPCR for viral RNA, CPE evaluation)

Procedure:

- Seed the host cells in multi-well plates and grow to a confluent monolayer.
- Infect the cells with the virus at a predetermined multiplicity of infection (MOI).
- After a 1-hour adsorption period, remove the viral inoculum and wash the cells.
- Add fresh culture medium containing various concentrations of the test inhibitor or vehicle control.
- Incubate the plates for a period relevant to the virus's replication cycle (e.g., 24, 48, or 72 hours).[7][8]
- At the end of the incubation, quantify viral replication using the chosen method. For cytopathic effect (CPE) assays, this can be done over 2-4 days.[5]
- Determine the EC50 value of the inhibitor.

Protocol 3: Cell Proliferation Assay

This protocol is based on studies investigating the anticancer effects of PI4KIII β inhibitors.[9]

Objective: To evaluate the impact of a PI4KIII β inhibitor on the proliferation of cancer cells.

Materials:

- Cancer cell line of interest
- Cell culture medium and supplements
- Test inhibitor
- Proliferation assay reagent (e.g., WST-1, MTT, or CellTiter-Glo)
- Plate reader

Procedure:

- Seed the cancer cells in 96-well plates at a low density.
- Allow the cells to attach overnight.
- Replace the medium with fresh medium containing serial dilutions of the test inhibitor or vehicle control.
- Incubate the cells for an extended period, typically 3 to 7 days, to allow for multiple rounds of cell division.[9]
- At the end of the treatment period, add the proliferation assay reagent according to the manufacturer's instructions.
- Measure the absorbance or luminescence using a plate reader.
- Calculate the percentage of cell growth inhibition and determine the GI50 value.

Mandatory Visualizations

Signaling Pathway Diagram

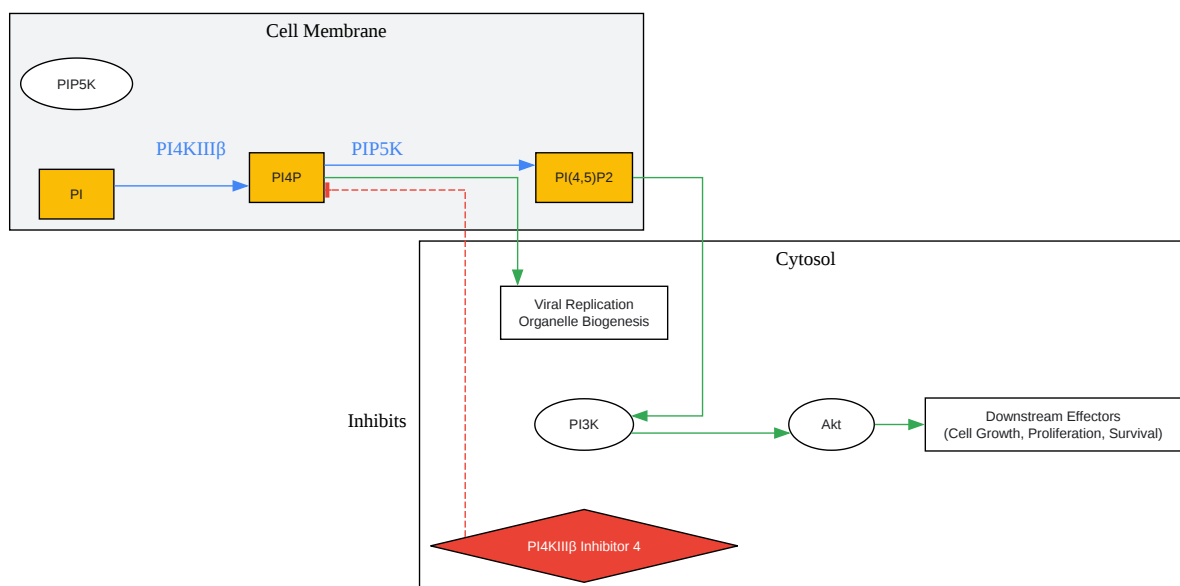

[Click to download full resolution via product page](#)

Caption: PI4KIIIβ Signaling Pathway and Point of Inhibition.

Experimental Workflow Diagram

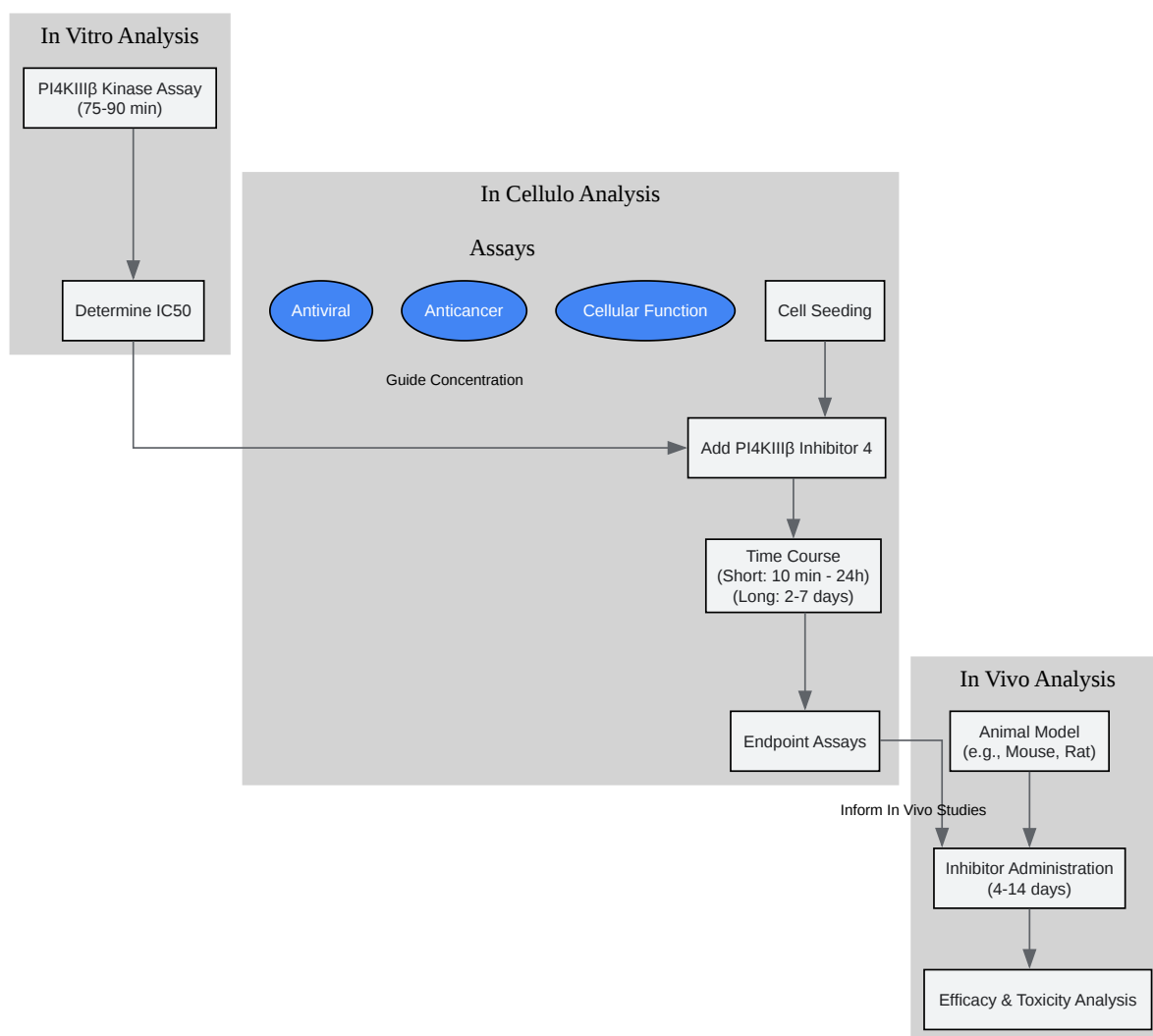

[Click to download full resolution via product page](#)

Need Custom Synthesis?

BenchChem offers custom synthesis for rare earth carbides and specific isotopic labeling.

Email: info@benchchem.com or [Request Quote Online](#).

References

- [1. medchemexpress.com \[medchemexpress.com\]](https://www.medchemexpress.com)
- [2. uochb.cz \[uochb.cz\]](https://www.uochb.cz)
- [3. Phosphatidylinositol 4-kinases: Function, structure, and inhibition - PubMed \[pubmed.ncbi.nlm.nih.gov\]](https://pubmed.ncbi.nlm.nih.gov/)
- [4. researchgate.net \[researchgate.net\]](https://www.researchgate.net)
- [5. researchgate.net \[researchgate.net\]](https://www.researchgate.net)
- [6. Pharmacological and Genetic Targeting of the PI4KA Enzyme Reveals Its Important Role in Maintaining Plasma Membrane Phosphatidylinositol 4-Phosphate and Phosphatidylinositol 4,5-Bisphosphate Levels - PMC \[pmc.ncbi.nlm.nih.gov\]](https://pubmed.ncbi.nlm.nih.gov/)
- [7. PI4KIII \$\beta\$ Activity Regulates Lateral Root Formation Driven by Endocytic Trafficking to the Vacuole - PMC \[pmc.ncbi.nlm.nih.gov\]](https://pubmed.ncbi.nlm.nih.gov/)
- [8. Inhibition of protein kinase D and its substrate phosphatidylinositol-4 kinase III beta blocks common human coronavirus replication - PMC \[pmc.ncbi.nlm.nih.gov\]](https://pubmed.ncbi.nlm.nih.gov/)
- [9. PI4K \(inhibitors, antagonists, agonists\)-ProbeChem.com \[probechem.com\]](https://www.probechem.com)
- [10. Stabilization of Phosphatidylinositol 4-Kinase Type II \$\beta\$ by Interaction with Hsp90 - PMC \[pmc.ncbi.nlm.nih.gov\]](https://pubmed.ncbi.nlm.nih.gov/)
- [11. Phosphatidylinositol-4 kinase III beta and oxysterol-binding protein accumulate unesterified cholesterol on poliovirus-induced membrane structure - PubMed \[pubmed.ncbi.nlm.nih.gov\]](https://pubmed.ncbi.nlm.nih.gov/)
- [12. researchgate.net \[researchgate.net\]](https://www.researchgate.net)
- To cite this document: BenchChem. [Optimal Treatment Duration for PI4KIII Beta Inhibitors: Application Notes and Protocols]. BenchChem, [2026]. [Online PDF]. Available at: [\[https://www.benchchem.com/product/b15602817/docs#optimal-treatment-duration-for-pi4kiii-beta-inhibitors-application-notes-and-protocols\]](https://www.benchchem.com/product/b15602817/docs#optimal-treatment-duration-for-pi4kiii-beta-inhibitors-application-notes-and-protocols)

Disclaimer & Data Validity:

The information provided in this document is for Research Use Only (RUO) and is strictly not intended for diagnostic or therapeutic procedures. While BenchChem strives to provide accurate protocols, we make no warranties, express or implied, regarding the fitness of this product for every specific experimental setup.

Technical Support: The protocols provided are for reference purposes. Unsure if this reagent suits your experiment?

Need Industrial/Bulk Grade? [Request Custom Synthesis Quote](#)

BenchChem

Our mission is to be the trusted global source of essential and advanced chemicals, empowering scientists and researchers to drive progress in science and industry.

Contact

Address: 3281 E Guasti Rd
Ontario, CA 91761, United States
Phone: (601) 213-4426
Email: info@benchchem.com

[Contact our Ph.D. Support Team for a compatibility check](#)