

Application of ML192 in Inflammation Research Models: Application Notes and Protocols

Author: BenchChem Technical Support Team. **Date:** April 2026

Compound of Interest

Compound Name: *ML192*
Cat. No.: *B15602871*

[Get Quote](#)

For Researchers, Scientists, and Drug Development Professionals

Introduction

ML192 is a potent and selective antagonist of the G protein-coupled receptor 55 (GPR55). Emerging evidence implicates GPR55 in pro-inflammatory signaling, positioning it as a novel therapeutic target for inflammatory diseases. **ML192**, also known as CID-1434953, offers a valuable pharmacological tool to investigate the role of GPR55 in various inflammation research models. These application notes provide an overview of **ML192**, its mechanism of action, and detailed protocols for its use in studying inflammation.

Mechanism of Action

ML192 exerts its effects by specifically binding to and inhibiting the GPR55 receptor. GPR55 activation, often by its endogenous ligand lysophosphatidylinositol (LPI), has been shown to initiate downstream signaling cascades that contribute to inflammatory responses. **ML192** blocks these pro-inflammatory signals. The primary mechanism of action involves the inhibition of:

- β -arrestin trafficking: **ML192** prevents the recruitment of β -arrestin to the GPR55 receptor, a crucial step in receptor desensitization and signaling.
- ERK1/2 Phosphorylation: It inhibits the phosphorylation of extracellular signal-regulated kinases 1 and 2 (ERK1/2), key components of the MAPK signaling pathway involved in cell proliferation, differentiation, and inflammation.
- PKC β II Translocation: **ML192** impedes the translocation of Protein Kinase C β II (PKC β II), another important mediator in inflammatory signaling pathways.

By inhibiting these pathways, **ML192** can effectively attenuate the production of pro-inflammatory cytokines and reduce immune cell recruitment and activation.

Quantitative Data Summary

The following tables summarize the key quantitative data for **ML192** and the effects of GPR55 antagonism in inflammatory models.

Table 1: In Vitro Activity of **ML192**

Parameter	Value	Cell Line/Assay	Reference
IC50 for GPR55 Antagonism	1.08 μ M	β -arrestin recruitment assay	[1]
IC50 for ERK1/2 Phosphorylation Inhibition	1.1 μ M	GPR55-expressing U2OS cells	[2]
Selectivity (Antagonist activity)	>45-fold vs. GPR35, CB1, CB2	Various cell-based assays	[1]

Table 2: Effects of GPR55 Antagonists in Preclinical Inflammation Models

Model	GPR55 Antagonist Used	Key Findings	Reference
DSS-induced Colitis (Mouse)	CID16020046	Reduced inflammation scores, MPO activity, TNF- α , and IL-1 β levels. Decreased macrophage and lymphocyte recruitment.	[2]
TNBS-induced Colitis (Mouse)	CID16020046	Lowered levels of Cox-2, IL-1 β , and IL-6.	[2]
Collagen-Induced Arthritis (Mouse)	CID16020046	Alleviated arthritis symptoms, reduced serum IgG, IL-1 β , IL-6, IFN- γ , and IL-17A.	[3]
LPS-induced Endotoxemia (Rat)	CID16020046, O-1918	Reduced leukocyte adherence and plasma levels of TNF- α and IL-6.	[4]
Inflammatory Pain (Rat)	GPR55 blockade in PAG	Mitigated inflammatory pain.	[5]
LPS-activated Primary Microglia	KIT 10	Prevented PGE2 release, reduced mPGES-1 and COX-2 synthesis, and inhibited NF- κ B signaling.	[6]

Signaling Pathways and Experimental Workflows

GPR55 Pro-Inflammatory Signaling Pathway

The following diagram illustrates the signaling cascade initiated by GPR55 activation and the points of inhibition by **ML192**.

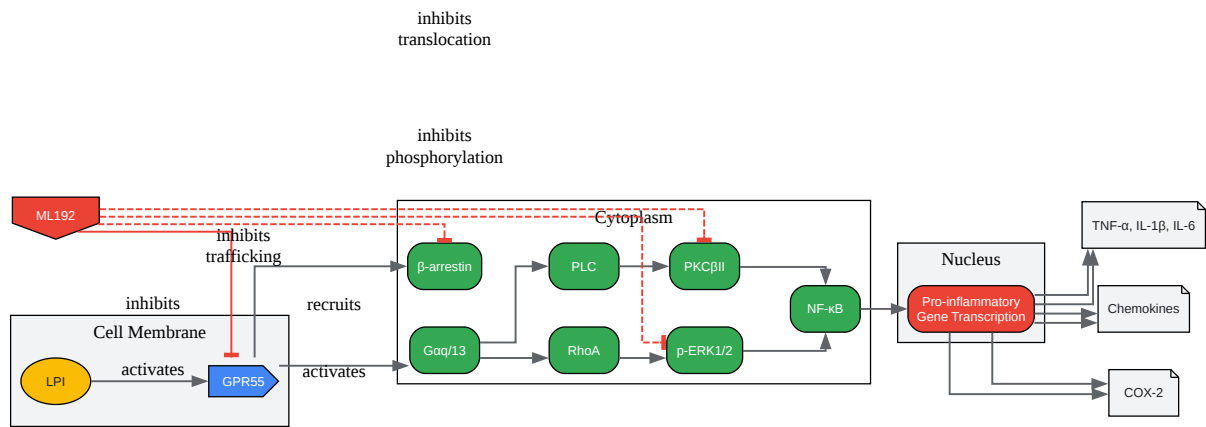

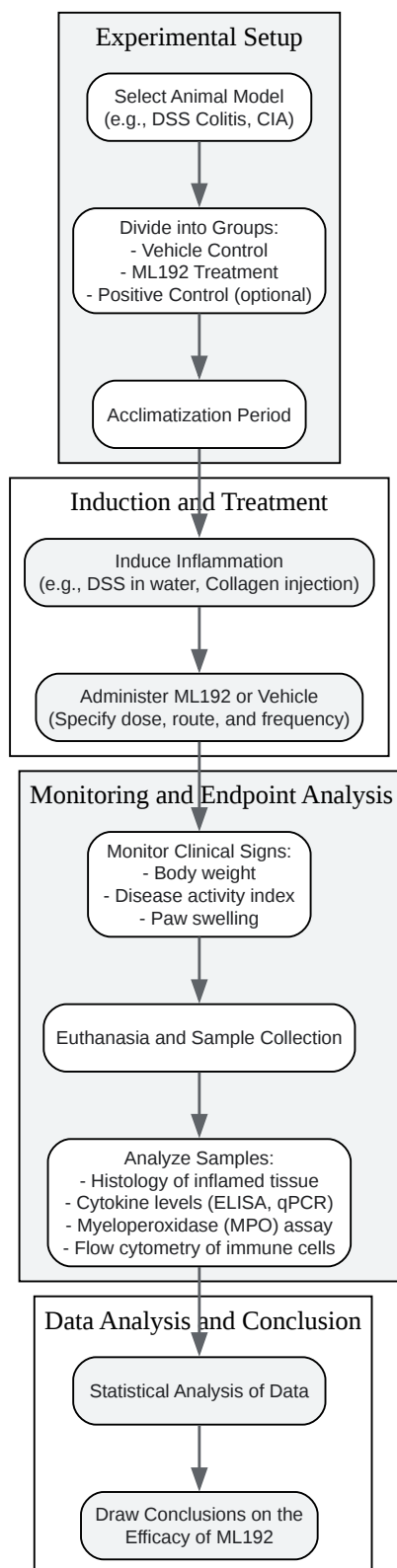

[Click to download full resolution via product page](#)

Need Custom Synthesis?

BenchChem offers custom synthesis for rare earth carbides and specific isotopic labeling.

Email: info@benchchem.com or [Request Quote Online](#).

References

- [1. Screening for Selective Ligands for GPR55 - Antagonists - Probe Reports from the NIH Molecular Libraries Program - NCBI Bookshelf \[ncbi.nlm.nih.gov\]](#)
- [2. The GPR55 antagonist CID16020046 protects against intestinal inflammation - PMC \[pmc.ncbi.nlm.nih.gov\]](#)
- [3. mdpi.com \[mdpi.com\]](#)
- [4. Inhibition of GPR 55 improves dysregulated immune response in experimental sepsis - PubMed \[pubmed.ncbi.nlm.nih.gov\]](#)
- [5. Contribution of G Protein-Coupled Receptor 55 to Periaqueductal Gray-Mediated Antinociception in the Inflammatory Pain - PubMed \[pubmed.ncbi.nlm.nih.gov\]](#)
- [6. Effects of a Novel GPR55 Antagonist on the Arachidonic Acid Cascade in LPS-Activated Primary Microglial Cells - PMC \[pmc.ncbi.nlm.nih.gov\]](#)
- To cite this document: BenchChem. [Application of ML192 in Inflammation Research Models: Application Notes and Protocols]. BenchChem, [2026]. [Online PDF]. Available at: [\[https://www.benchchem.com/product/b15602871/docs#application-of-ml192-in-inflammation-research-models-application-notes-and-protocols\]](https://www.benchchem.com/product/b15602871/docs#application-of-ml192-in-inflammation-research-models-application-notes-and-protocols)

Disclaimer & Data Validity:

The information provided in this document is for Research Use Only (RUO) and is strictly not intended for diagnostic or therapeutic procedures. While BenchChem strives to provide accurate protocols, we make no warranties, express or implied, regarding the fitness of this product for every specific experimental setup.

Technical Support: The protocols provided are for reference purposes. Unsure if this reagent suits your experiment?

Need Industrial/Bulk Grade? [Request Custom Synthesis Quote](#)

BenchChem

Our mission is to be the trusted global source of essential and advanced chemicals, empowering scientists and researchers to drive progress in science and industry.

Contact

Address: 3281 E Guasti Rd
Ontario, CA 91761, United States
Phone: (601) 213-4426
Email: info@benchchem.com

[Contact our Ph.D. Support Team for a compatibility check](#)