

Application Notes and Protocols for Protein Degradation Studies Using Lcl-peg3-N3

Author: BenchChem Technical Support Team. **Date:** April 2026

Compound of Interest

Compound Name: Lcl-peg3-N3

Cat. No.: B15602115

[Get Quote](#)

For Researchers, Scientists, and Drug Development Professionals

Introduction

Targeted protein degradation (TPD) has emerged as a powerful therapeutic modality that utilizes the cell's own ubiquitin-proteasome system (UPS) to selectively eliminate disease-causing proteins. Proteolysis-targeting chimeras (PROTACs) are heterobifunctional molecules at the forefront of this technology. They consist of a ligand that binds to a protein of interest (POI), a ligand for an E3 ubiquitin ligase, and a linker connecting the two. This tripartite complex formation leads to the ubiquitination and subsequent degradation of the POI.

Lcl-peg3-N3 is a valuable chemical tool for the synthesis of PROTACs. It is a decoy oligonucleotide E3 ligase ligand that specifically recruits Inhibitor of Apoptosis Proteins (IAPs). [1] The molecule features a PEG3 linker and a terminal azide (N3) group, which allows for the convenient attachment of a POI-binding moiety via click chemistry, such as the copper(I)-catalyzed azide-alkyne cycloaddition (CuAAC) or strain-promoted alkyne-azide cycloaddition (SPAAC).

A notable application of **Lcl-peg3-N3** is in the creation of degraders for proteins that lack small molecule binders, such as transcription factors. By using a decoy oligonucleotide that binds to

the target protein, a functional degrader can be synthesized. A prime example is the development of LCL-ER(dec), a chimeric molecule that degrades the Estrogen Receptor α (ER α) by linking an ER α -binding decoy oligonucleotide to **Lcl-peg3-N3**.^[1]

These application notes provide a comprehensive guide to the experimental design for protein degradation studies using **Lcl-peg3-N3**, with a focus on the characterization of novel degraders.

Data Presentation: Quantitative Analysis of Protein Degradation

A crucial aspect of characterizing a novel degrader is the quantitative assessment of its efficacy. The primary parameters used are the half-maximal degradation concentration (DC50) and the maximum percentage of degradation (Dmax). This data is typically generated from dose-response experiments and analyzed using Western blotting or other quantitative protein analysis methods.

While the seminal study by Naganuma et al. (2022) demonstrated the successful degradation of ER α using LCL-ER(dec) via Western blot analysis, specific DC50 and Dmax values were not explicitly reported in the primary publication.^[1] The table below provides a template for presenting such quantitative data, populated with representative values for a hypothetical degrader synthesized using **Lcl-peg3-N3**.

Degrader	Target Protein	Cell Line	DC50 (nM)	Dmax (%)	Time Point (h)	Reference
LCL-ER(dec)	ER α	MCF-7	Not Reported	>50% (qualitative)	24	[Naganuma et al., 2022] ^[1]
Representative Degrader X	Target Protein Y	Cell Line Z	50	90	24	[Hypothetical Data]

Signaling Pathways and Experimental Workflows

To aid in the conceptual understanding of the processes involved in targeted protein degradation and the experimental approaches to validate them, the following diagrams are provided.

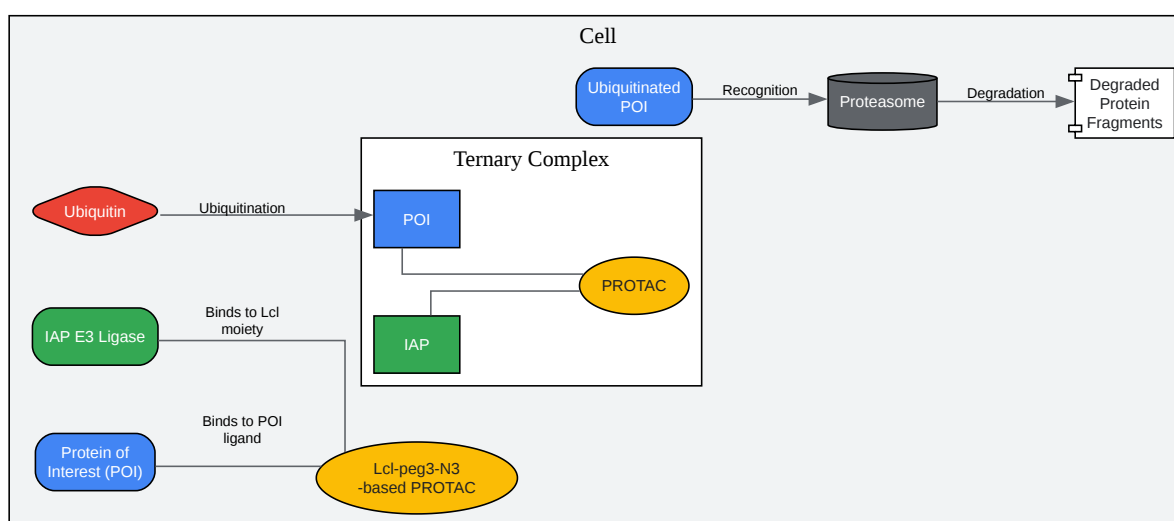

[Click to download full resolution via product page](#)

PROTAC-mediated protein degradation pathway.

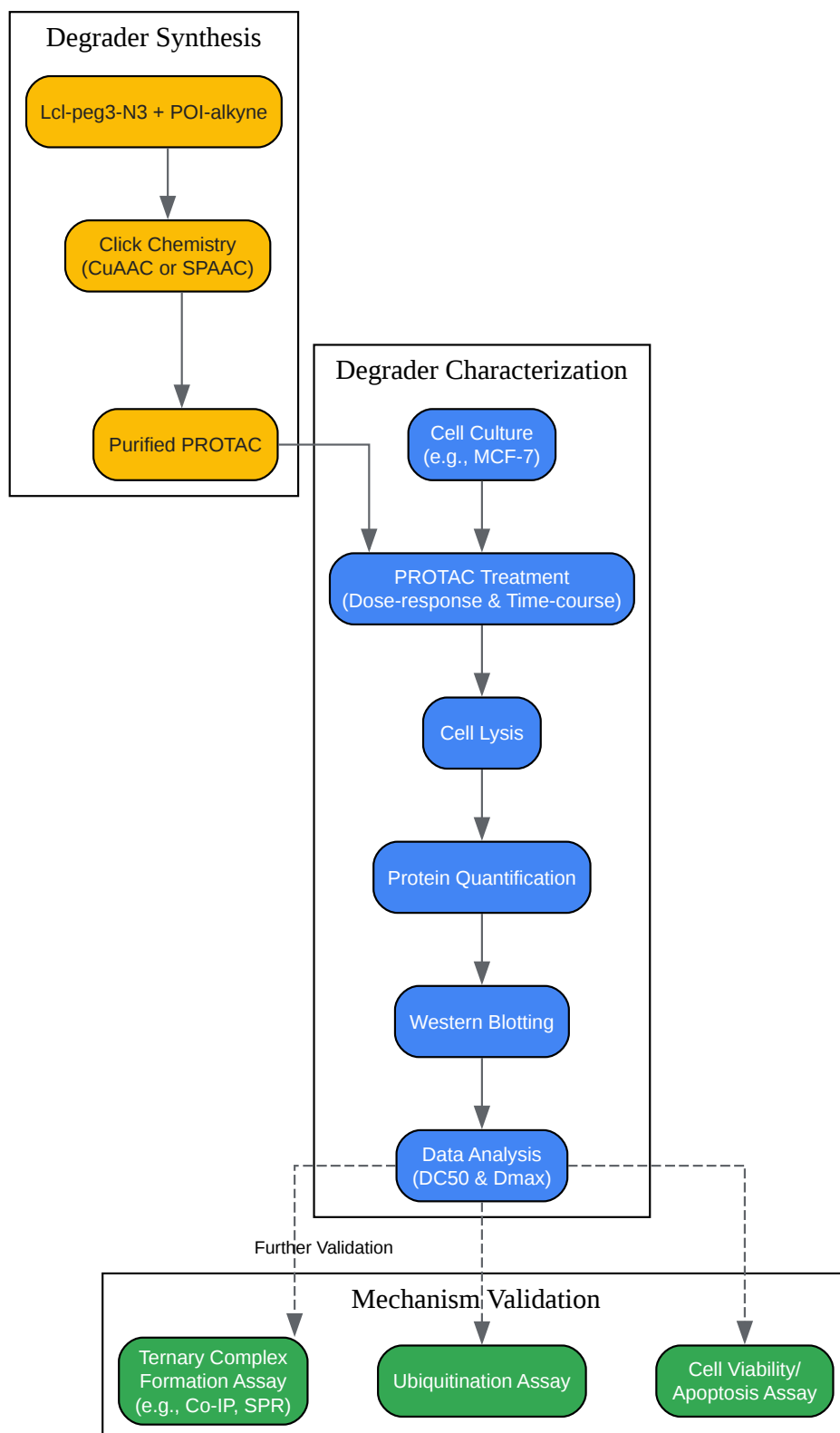

[Click to download full resolution via product page](#)

Experimental workflow for degrader characterization.

Experimental Protocols

Synthesis of Lcl-peg3-N3-based PROTAC via Click Chemistry

This protocol describes the copper(I)-catalyzed azide-alkyne cycloaddition (CuAAC) to conjugate **Lcl-peg3-N3** with an alkyne-modified POI-binding ligand.

Materials:

- **Lcl-peg3-N3**
- Alkyne-modified POI-binding ligand (e.g., alkyne-modified decoy oligonucleotide for ER α)
- Copper(II) sulfate (CuSO₄)
- Sodium ascorbate
- Tris(3-hydroxypropyltriazolylmethyl)amine (THPTA) or Tris((1-benzyl-1H-1,2,3-triazol-4-yl)methyl)amine (TBTA)
- Dimethyl sulfoxide (DMSO)
- Deionized water
- Purification system (e.g., HPLC)

Procedure:

- Prepare stock solutions:
 - **Lcl-peg3-N3** in DMSO.
 - Alkyne-modified POI ligand in water or a suitable buffer.
 - CuSO₄ in deionized water.
 - Sodium ascorbate in deionized water (prepare fresh).

- THPTA or TBTA in DMSO/water.
- In a microcentrifuge tube, combine the alkyne-modified POI ligand and **Lcl-peg3-N3** in a suitable solvent mixture (e.g., DMSO/water).
- Add the copper catalyst premix (CuSO₄ and THPTA/TBTA).
- Initiate the reaction by adding freshly prepared sodium ascorbate solution.
- Vortex the reaction mixture and incubate at room temperature for 1-4 hours, or as optimized.
- Monitor the reaction progress by LC-MS.
- Upon completion, purify the PROTAC product using reverse-phase HPLC.
- Confirm the identity and purity of the final product by mass spectrometry and NMR.

Western Blotting for Protein Degradation Assessment

This protocol details the steps to quantify the degradation of a target protein in cells treated with a PROTAC.

Materials:

- Cell line expressing the POI (e.g., MCF-7 for ER α)
- Cell culture medium and supplements
- PROTAC stock solution in DMSO
- Phosphate-buffered saline (PBS)
- Lysis buffer (e.g., RIPA buffer) with protease and phosphatase inhibitors
- BCA protein assay kit
- Laemmli sample buffer
- SDS-PAGE gels and electrophoresis apparatus

- PVDF or nitrocellulose membranes and transfer apparatus
- Blocking buffer (e.g., 5% non-fat milk or BSA in TBST)
- Primary antibody against the POI
- Primary antibody against a loading control (e.g., GAPDH, β -actin)
- HRP-conjugated secondary antibody
- Chemiluminescent substrate and imaging system

Procedure:

- Cell Seeding: Seed cells in multi-well plates at a density that ensures they are in the logarithmic growth phase at the time of treatment.
- PROTAC Treatment: Treat the cells with a serial dilution of the PROTAC to determine the dose-response. Include a vehicle control (DMSO). For time-course experiments, treat cells with a fixed concentration of the PROTAC and harvest at different time points.
- Cell Lysis: After treatment, wash the cells with ice-cold PBS and lyse them with lysis buffer on ice.
- Protein Quantification: Determine the protein concentration of each lysate using a BCA assay.
- Sample Preparation: Normalize the protein concentration of all samples and prepare them for SDS-PAGE by adding Laemmli sample buffer and boiling.
- SDS-PAGE and Transfer: Separate the proteins by SDS-PAGE and transfer them to a PVDF or nitrocellulose membrane.
- Immunoblotting:
 - Block the membrane with blocking buffer for 1 hour at room temperature.
 - Incubate the membrane with the primary antibody against the POI overnight at 4°C.

- Wash the membrane and incubate with the HRP-conjugated secondary antibody for 1 hour at room temperature.
- Wash the membrane again.
- Repeat the immunoblotting process for the loading control antibody.
- Detection and Analysis:
 - Apply the chemiluminescent substrate and capture the signal using an imaging system.
 - Quantify the band intensities using densitometry software.
 - Normalize the POI band intensity to the loading control band intensity.
 - Calculate the percentage of protein degradation relative to the vehicle control.
 - Plot the percentage of degradation against the PROTAC concentration to determine the DC50 and Dmax values.

Cell Viability Assay (MTT Assay)

This protocol is to assess the cytotoxic effects of the PROTAC on the treated cells.

Materials:

- Cells and culture medium
- 96-well plates
- PROTAC stock solution
- MTT (3-(4,5-dimethylthiazol-2-yl)-2,5-diphenyltetrazolium bromide) solution
- Solubilization solution (e.g., DMSO or 10% SDS in 0.01 M HCl)
- Microplate reader

Procedure:

- Cell Seeding: Seed cells in a 96-well plate and allow them to adhere overnight.
- PROTAC Treatment: Treat the cells with a serial dilution of the PROTAC and a vehicle control.
- Incubation: Incubate the cells for the desired time period (e.g., 24, 48, or 72 hours).
- MTT Addition: Add MTT solution to each well and incubate for 2-4 hours at 37°C to allow for the formation of formazan crystals.
- Solubilization: Add the solubilization solution to each well to dissolve the formazan crystals.
- Measurement: Read the absorbance at the appropriate wavelength (e.g., 570 nm) using a microplate reader.
- Analysis: Calculate the percentage of cell viability relative to the vehicle control and determine the IC50 value.

Conclusion

Lcl-peg3-N3 is a versatile building block for the synthesis of IAP-recruiting PROTACs, particularly for challenging targets like transcription factors. The protocols and guidelines presented here provide a robust framework for the design, synthesis, and characterization of novel protein degraders. Rigorous experimental validation, including quantitative assessment of protein degradation and evaluation of cellular effects, is essential for the successful development of new therapeutic agents based on this technology.

Need Custom Synthesis?

BenchChem offers custom synthesis for rare earth carbides and specific isotopic labeling.

Email: info@benchchem.com or [Request Quote Online](#).

References

- [1. Development of Chimeric Molecules That Degrade the Estrogen Receptor Using Decoy Oligonucleotide Ligands - PMC \[pmc.ncbi.nlm.nih.gov\]](#)

- To cite this document: BenchChem. [Application Notes and Protocols for Protein Degradation Studies Using Lcl-peg3-N3]. BenchChem, [2026]. [Online PDF]. Available at: [<https://www.benchchem.com/product/b15602115/docs#application-notes-and-protocols-for-protein-degradation-studies-using-lcl-peg3-n3>]

Disclaimer & Data Validity:

The information provided in this document is for Research Use Only (RUO) and is strictly not intended for diagnostic or therapeutic procedures. While BenchChem strives to provide accurate protocols, we make no warranties, express or implied, regarding the fitness of this product for every specific experimental setup.

Technical Support: The protocols provided are for reference purposes. Unsure if this reagent suits your experiment?

Need Industrial/Bulk Grade? [Request Custom Synthesis Quote](#)

BenchChem

Our mission is to be the trusted global source of essential and advanced chemicals, empowering scientists and researchers to drive progress in science and industry.

Contact

Address: 3281 E Guasti Rd
Ontario, CA 91761, United States
Phone: (601) 213-4426
Email: info@benchchem.com

[Contact our Ph.D. Support Team for a compatibility check](#)