

Application Notes and Protocols for Developing MUC5AC-Targeted Drug Delivery Systems

Author: BenchChem Technical Support Team. **Date:** April 2026

Compound of Interest

Compound Name: MUC5AC motif peptide

Cat. No.: B15602850

[Get Quote](#)

For Researchers, Scientists, and Drug Development Professionals

Introduction

Mucin 5AC (MUC5AC) is a gel-forming mucin that is overexpressed in a variety of pathological conditions, including chronic obstructive pulmonary disease (COPD), asthma, inflammatory bowel disease (IBD), and several types of cancer such as pancreatic, lung, and colon cancer. [1][2][3][4][5][6][7] In healthy tissues, MUC5AC plays a protective role in the epithelial linings. However, its aberrant expression and glycosylation in diseased states contribute to pathogenesis and create a unique therapeutic target.[3] This document provides detailed application notes and experimental protocols for the development of drug delivery systems specifically targeting MUC5AC. These systems aim to enhance therapeutic efficacy by delivering drugs directly to the site of disease, thereby reducing systemic toxicity.[8][9][10][11][12]

Key Therapeutic Strategies

MUC5AC-targeted drug delivery can be leveraged for several therapeutic approaches:

- **Anti-inflammatory Therapy:** For diseases like IBD and COPD, targeted delivery of anti-inflammatory agents such as glucocorticoids can mitigate local inflammation.[1][2]
- **Chemotherapy:** In cancers overexpressing MUC5AC, targeted nanoparticles can deliver cytotoxic drugs like gemcitabine, nab-paclitaxel, and epirubicin directly to tumor cells, improving their therapeutic index.[5][13][14]
- **Gene Therapy:** RNA interference (RNAi) therapeutics can be designed to silence the MUC5AC gene, reducing mucus hypersecretion in respiratory diseases.[15][16]
- **Molecular Imaging:** Nanoparticles conjugated with imaging agents can be used for the diagnosis and monitoring of MUC5AC-expressing tumors.[17][18][19]

MUC5AC-Targeting Moieties

The selection of a high-affinity and specific targeting ligand is crucial for the success of the drug delivery system. Commonly used moieties include:

- **Monoclonal Antibodies (mAbs):** Highly specific antibodies that recognize and bind to epitopes on the MUC5AC protein. Examples include anti-MUC5AC antibodies and NPC-1C. [1][2][13][17]
- **Aptamers:** Single-stranded DNA or RNA oligonucleotides that can fold into unique three-dimensional structures to bind to specific targets. The 5TR1 DNA aptamer, for instance, recognizes the MUC5AC glycoprotein.[14]

Nanoparticle-Based Delivery Platforms

A variety of nanoparticle platforms can be engineered for MUC5AC-targeted drug delivery, each with its own set of advantages.[8][20][21][22]

- **Polymeric Nanoparticles:** Biocompatible and biodegradable polymers like poly(lactic-co-glycolic acid) (PLGA) can encapsulate a wide range of drugs.[8]
- **Liposomes:** Vesicles composed of a lipid bilayer that can carry both hydrophilic and hydrophobic drugs.[19]

- Inorganic Nanoparticles: Materials such as gold or iron oxide nanoparticles can be used for both drug delivery and imaging (theranostics).[\[19\]](#)[\[20\]](#)

Data Presentation: Physicochemical Properties of MUC5AC-Targeted Nanoparticles

The physicochemical properties of nanoparticles are critical for their in vivo performance. The following table summarizes typical parameters for consideration.

Nanoparticle Type	Targeting Ligand	Average Size (nm)	Drug Loading Efficiency (%)	Reference
BSA-PLLA	-	94 - 162	Not Specified	[23]
Chitosan-based	-	100 - 200	Varies	[24]

Note: Specific drug loading efficiencies are highly dependent on the drug, polymer/lipid composition, and preparation method.

Data Presentation: In Vivo Targeting Efficacy

The ability of the drug delivery system to accumulate at the target site is a key measure of its effectiveness.

Animal Model	Targeting Moiety	Imaging Agent	Tumor-to-Background Ratio (TBR)	Time Point	Reference
Pancreatic Cancer PDOX	Anti-MUC5AC mAb	IRDye800CW	2.46 ± 0.465	48 h	[17]
Pancreatic Cancer Subcutaneous	Anti-MUC5AC mAb	IRDye800CW	4.35 ± 0.177	72 h	[17]
Pancreatic Cancer Liver Metastasis PDOX	Anti-MUC5AC mAb	IR800	1.787 ± 0.336	72 h	[18][25]

Signaling Pathways Involving MUC5AC

Understanding the signaling pathways that regulate MUC5AC expression can provide insights into disease mechanisms and reveal additional therapeutic targets.

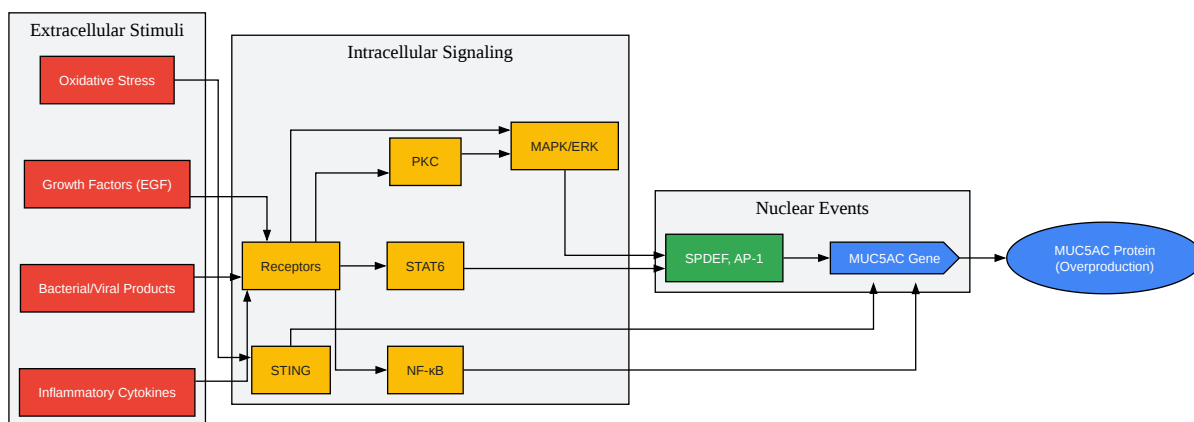

[Click to download full resolution via product page](#)

Caption: Signaling pathways regulating MUC5AC expression.

Experimental Protocols

Protocol 1: Synthesis of Anti-MUC5AC Antibody-Conjugated Polymeric Nanoparticles

This protocol describes the synthesis of drug-loaded polymeric nanoparticles and their subsequent conjugation with an anti-MUC5AC antibody.

Materials:

- Poly(lactic-co-glycolic acid) (PLGA)
- Therapeutic drug (e.g., glucocorticoid, chemotherapeutic)

- Polyvinyl alcohol (PVA) or another suitable surfactant
- Dichloromethane (DCM) or other organic solvent
- N-(3-Dimethylaminopropyl)-N'-ethylcarbodiimide hydrochloride (EDC)
- N-hydroxysuccinimide (NHS)
- Anti-MUC5AC monoclonal antibody
- Phosphate-buffered saline (PBS)
- Dialysis membrane (MWCO 10-14 kDa)
- Ultrasonic probe or homogenizer

Methodology:

- Nanoparticle Formulation (Solvent Evaporation Method):
 1. Dissolve PLGA and the therapeutic drug in DCM.
 2. Prepare an aqueous solution of PVA.
 3. Add the organic phase to the aqueous phase under high-speed homogenization or sonication to form an oil-in-water (o/w) emulsion.
 4. Stir the emulsion at room temperature for several hours to allow for solvent evaporation and nanoparticle hardening.
 5. Collect the nanoparticles by centrifugation, wash with deionized water to remove excess PVA, and lyophilize for storage.
- Antibody Conjugation:
 1. Activate the carboxyl groups on the surface of the PLGA nanoparticles by reacting them with EDC and NHS in PBS (pH 7.4) for 15-30 minutes at room temperature.
 2. Centrifuge and wash the activated nanoparticles to remove excess EDC and NHS.

3. Immediately add the anti-MUC5AC antibody to the activated nanoparticle suspension and incubate for 2-4 hours at room temperature with gentle stirring.
4. Quench the reaction by adding a suitable blocking agent (e.g., glycine or ethanolamine).
5. Purify the antibody-conjugated nanoparticles by dialysis against PBS to remove unconjugated antibodies and other reactants.
6. Store the final product at 4°C.

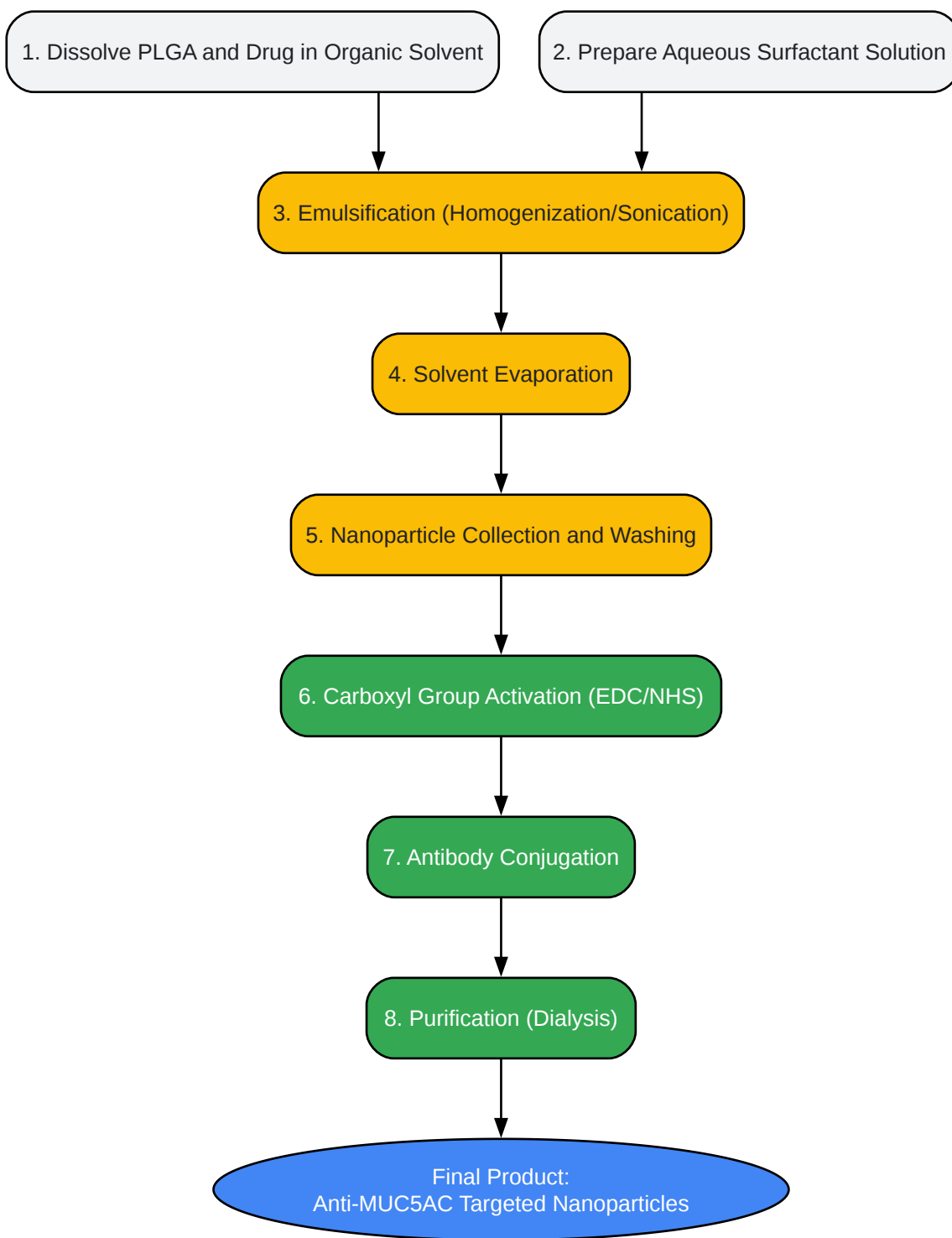

[Click to download full resolution via product page](#)

Need Custom Synthesis?

BenchChem offers custom synthesis for rare earth carbides and specific isotopic labeling.

Email: info@benchchem.com or [Request Quote Online](#).

References

- [1. Active nanoparticle targeting of MUC5AC ameliorates therapeutic outcome in experimental colitis - PubMed \[pubmed.ncbi.nlm.nih.gov\]](#)
- [2. Active nanoparticle targeting of MUC5AC ameliorates therapeutic outcome in experimental colitis - Nanoscale \(RSC Publishing\) \[pubs.rsc.org\]](#)
- [3. Ramifications of secreted mucin MUC5AC in malignant journey: a holistic view - PMC \[pmc.ncbi.nlm.nih.gov\]](#)
- [4. mdpi.com \[mdpi.com\]](#)
- [5. Mucin-based Targeted Pancreatic Cancer Therapy - PMC \[pmc.ncbi.nlm.nih.gov\]](#)
- [6. Natural inhibitors on airway mucin: Molecular insight into the therapeutic potential targeting MUC5AC expression and production - PubMed \[pubmed.ncbi.nlm.nih.gov\]](#)
- [7. Abrogation of MUC5AC Expression Contributes to the Apoptosis and Cell Cycle Arrest of Colon Cancer Cells - PubMed \[pubmed.ncbi.nlm.nih.gov\]](#)
- [8. Research Portal \[iro.uiowa.edu\]](#)
- [9. researchgate.net \[researchgate.net\]](#)
- [10. jocpr.com \[jocpr.com\]](#)
- [11. Recent Advances in Targeted Drug Delivery Strategy for Enhancing Oncotherapy - PMC \[pmc.ncbi.nlm.nih.gov\]](#)
- [12. Advances in nanomaterial-based targeted drug delivery systems - PMC \[pmc.ncbi.nlm.nih.gov\]](#)
- [13. Effect of a MUC5AC Antibody \(NPC-1C\) Administered With Second-Line Gemcitabine and Nab-Paclitaxel on the Survival of Patients With Advanced Pancreatic Ductal Adenocarcinoma: A Randomized Clinical Trial - PMC \[pmc.ncbi.nlm.nih.gov\]](#)
- [14. Dual-targeting CD44 and mucin by hyaluronic acid and 5TR1 aptamer for epirubicin delivery into cancer cells: Synthesis, characterization, in vitro and in vivo evaluation - PMC \[pmc.ncbi.nlm.nih.gov\]](#)
- [15. atsjournals.org \[atsjournals.org\]](#)
- [16. arrowheadpharma.com \[arrowheadpharma.com\]](#)
- [17. Fluorescent Anti-MUC5AC Brightly Targets Pancreatic Cancer in a Patient-derived Orthotopic Xenograft | In Vivo \[iv.iijournals.org\]](#)
- [18. Highly Selective Targeting of Pancreatic Cancer in the Liver with a Near-Infrared Anti-MUC5AC Probe in a PDOX Mouse Model: A Proof-of-Concept Study - PMC](#)

[[pmc.ncbi.nlm.nih.gov](https://pubmed.ncbi.nlm.nih.gov)]

- [19. benthamdirect.com](https://www.benthamdirect.com) [[benthamdirect.com](https://www.benthamdirect.com)]
- [20. mdpi.com](https://www.mdpi.com) [[mdpi.com](https://www.mdpi.com)]
- [21. mdpi.com](https://www.mdpi.com) [[mdpi.com](https://www.mdpi.com)]
- [22. Recent Advances in Micro- and Nano-Drug Delivery Systems Based on Natural and Synthetic Biomaterials - PMC](#) [[pmc.ncbi.nlm.nih.gov](https://pubmed.ncbi.nlm.nih.gov)]
- [23. researchgate.net](https://www.researchgate.net) [[researchgate.net](https://www.researchgate.net)]
- [24. Drug Loading in Chitosan-Based Nanoparticles - PMC](#) [[pmc.ncbi.nlm.nih.gov](https://pubmed.ncbi.nlm.nih.gov)]
- [25. Highly Selective Targeting of Pancreatic Cancer in the Liver with a Near-Infrared Anti-MUC5AC Probe in a PDOX Mouse Model: A Proof-of-Concept Study](#) [escholarship.org]
- To cite this document: BenchChem. [Application Notes and Protocols for Developing MUC5AC-Targeted Drug Delivery Systems]. BenchChem, [2026]. [Online PDF]. Available at: [<https://www.benchchem.com/product/b15602850/docs#application-notes-and-protocols-for-developing-muc5ac-targeted-drug-delivery-systems>]

Disclaimer & Data Validity:

The information provided in this document is for Research Use Only (RUO) and is strictly not intended for diagnostic or therapeutic procedures. While BenchChem strives to provide accurate protocols, we make no warranties, express or implied, regarding the fitness of this product for every specific experimental setup.

Technical Support: The protocols provided are for reference purposes. Unsure if this reagent suits your experiment?

Need Industrial/Bulk Grade? [Request Custom Synthesis Quote](#)

BenchChem

Our mission is to be the trusted global source of essential and advanced chemicals, empowering scientists and researchers to drive progress in science and industry.

Contact

Address: 3281 E Guasti Rd
Ontario, CA 91761, United States
Phone: (601) 213-4426
Email: info@benchchem.com

Contact our Ph.D. Support Team for a compatibility check