

Technical Support Center: PrOF NMR Experiments with (S)-GSK1379725A

Author: BenchChem Technical Support Team. **Date:** April 2026

Compound of Interest

Compound Name: (S)-GSK1379725A

Cat. No.: B15601694

[Get Quote](#)

This technical support center provides troubleshooting guidance and frequently asked questions (FAQs) for researchers utilizing Protein-Observed Fluorine (PrOF) NMR to study the interaction of **(S)-GSK1379725A** with its target proteins, such as the BPTF bromodomain.

Frequently Asked Questions (FAQs) & Troubleshooting

This section addresses common issues encountered during PrOF NMR experiments with **(S)-GSK1379725A**, from sample preparation to data analysis.

Q1: Why are my ^{19}F NMR signals broad or completely absent?

Broad or missing signals are a common issue in NMR and can stem from several factors. Here's a systematic approach to troubleshoot this problem:

- Poor Magnetic Field Homogeneity (Shimming): An improperly shimmed magnet is a primary cause of broad peaks.
 - Solution: Always perform automated shimming before your experiment. For challenging samples, manual shimming may be necessary to optimize the field homogeneity.

- High Sample Viscosity: Concentrated protein solutions can be viscous, leading to slower molecular tumbling and broader lines.
 - Solution: If possible, lower the protein concentration. Ensure your buffer conditions are optimal for protein solubility and stability.
- Paramagnetic Impurities: The presence of dissolved oxygen or trace metal ions can significantly shorten relaxation times, resulting in peak broadening.
 - Solution: Degas your sample by bubbling a gentle stream of an inert gas like nitrogen or argon through it before sealing the NMR tube.
- Sample Precipitation: If the protein or ligand is not fully soluble or precipitates over time, it will lead to severe line broadening.
 - Solution: Visually inspect your sample for any signs of precipitation. You may need to adjust buffer conditions (pH, salt concentration) or lower the concentration of your protein or ligand.
- Chemical Exchange Broadening: This occurs when the binding and dissociation of **(S)-GSK1379725A** is on a timescale comparable to the NMR experiment (intermediate exchange). The BPTF bromodomain interaction with **(S)-GSK1379725A** is known to be in the intermediate exchange regime, which can cause significant line broadening.[1]
 - Solution: Acquiring spectra at different temperatures can sometimes shift the exchange rate into the fast or slow regime, resulting in sharper peaks. Additionally, specialized pulse sequences can sometimes help to mitigate the effects of exchange broadening.[2]

Q2: My signal-to-noise ratio is poor. How can I improve it?

A low signal-to-noise ratio can make it difficult to detect weak signals or accurately measure peak intensities.

- Increase the Number of Scans: The signal-to-noise ratio increases with the square root of the number of scans. Doubling the number of scans will increase the signal-to-noise by a factor of approximately 1.4.

- **Optimize Acquisition Parameters:** Ensure your relaxation delay (d1) is sufficiently long (typically 1-5 times the T1 relaxation time of your fluorine nucleus) to allow for full relaxation between scans.
- **Increase Sample Concentration:** If solubility permits, increasing the concentration of your ^{19}F -labeled protein will directly improve the signal strength.
- **Use a Cryoprobe:** If available, a cryogenically cooled probe significantly enhances sensitivity, leading to a much better signal-to-noise ratio in a shorter amount of time.

Q3: I'm observing unexpected peaks or artifacts in my spectrum. What could be the cause?

Artifacts can complicate spectral interpretation and analysis.

- **Baseline Roll:** A non-flat baseline can be caused by a very intense signal or issues with the receiver.
 - **Solution:** Apply a baseline correction algorithm during data processing. Most NMR processing software has automated and manual baseline correction tools.[\[1\]](#)
- **Phasing Errors:** Incorrectly phased spectra will have distorted peak shapes.
 - **Solution:** Manually phase your spectrum during data processing to ensure all peaks have a pure absorption lineshape.[\[3\]](#)
- **Contaminants:** Sharp signals may arise from small molecule impurities containing fluorine.
 - **Solution:** Ensure high purity of your protein and ligand. Sharp signals from impurities can sometimes be distinguished from the broader protein signals.

Q4: How do I choose the right reference compound for my ^{19}F NMR experiment?

Proper referencing of your ^{19}F NMR spectrum is crucial for accurate chemical shift determination.

- **Internal vs. External Referencing:** An internal reference is added directly to your sample, while an external reference is placed in a capillary inside the NMR tube. Internal references are generally preferred for higher accuracy.

- **Common Reference Compounds:** Trifluoroacetic acid (TFA) or sodium trifluoroacetate are often used as internal references in aqueous samples. The choice of reference should be consistent across all experiments in a study.^[4]
- **Inertness:** The reference compound should not interact with your protein or ligand.

Quantitative Data Summary

The following tables provide typical experimental parameters for PrOF NMR experiments. Note that optimal values may vary depending on the specific protein, ligand, and NMR instrument used.

Table 1: Typical Sample Conditions for PrOF NMR Titration

Parameter	Typical Value	Reference
¹⁹ F-Labeled Protein Concentration	25 - 100 μM	[5]
(S)-GSK1379725A Stock Concentration	10 - 50 mM in DMSO	[1]
Final DMSO Concentration	< 5% (v/v)	[1]
Buffer	Phosphate or Tris buffer, pH 7.0-8.0	[5]
D ₂ O Content	5-10% for locking	[6]

Table 2: Typical 1D ¹⁹F NMR Acquisition Parameters

Parameter	Typical Value	Reference
Spectrometer Frequency	≥ 400 MHz for ^1H	
Pulse Program	zgfhig (Bruker) or equivalent ^1H -decoupled	[7]
Spectral Width (SW)	30 - 200 ppm	[7]
Acquisition Time (AQ)	1 - 2 seconds	
Relaxation Delay (d1)	1 - 5 seconds	[7]
Number of Scans (NS)	128 - 1024 (or more for low concentration)	
Temperature	298 K (25 °C)	

Experimental Protocols

Detailed Protocol for ProF NMR Titration to Determine Binding Affinity (Kd)

This protocol outlines the steps for determining the dissociation constant (Kd) of **(S)-GSK1379725A** binding to a ^{19}F -labeled protein by monitoring changes in the ^{19}F chemical shift.

1. Sample Preparation: a. Prepare a stock solution of your purified ^{19}F -labeled protein (e.g., BPTF bromodomain) at a concentration of 25-100 μM in a suitable NMR buffer (e.g., 50 mM sodium phosphate, 150 mM NaCl, pH 7.4) containing 10% D_2O . b. Prepare a concentrated stock solution of **(S)-GSK1379725A** (e.g., 20 mM) in deuterated DMSO.
2. NMR Instrument Setup: a. Tune and match the NMR probe for ^{19}F . b. Lock the spectrometer on the D_2O signal of your sample. c. Shim the magnet to achieve good field homogeneity.
3. Data Acquisition: a. Record a reference 1D ^{19}F NMR spectrum of the protein alone. Use the parameters outlined in Table 2 as a starting point. b. Add a small aliquot of the **(S)-GSK1379725A** stock solution to the protein sample. Ensure thorough mixing. c. Record a 1D ^{19}F NMR spectrum. d. Repeat step 3b and 3c for a series of increasing ligand concentrations. Aim for a final ligand concentration that is at least 10-fold higher than the expected Kd.

4. Data Processing: a. Process all spectra uniformly using software such as TopSpin, Mnova, or NMRPipe.[8][9][10][11] b. Apply Fourier transformation, phase correction, and baseline correction to each spectrum. c. Reference the spectra to an appropriate internal or external standard.

5. Data Analysis: a. For each spectrum, determine the chemical shift of the ^{19}F signal of interest. b. Calculate the chemical shift perturbation (CSP or $\Delta\delta$) for each titration point relative to the spectrum of the protein alone. c. Plot the CSP as a function of the total ligand concentration. d. Fit the resulting binding isotherm to the following equation to determine the K_d : [12][13]

Visualizations

BPTF Signaling Pathway

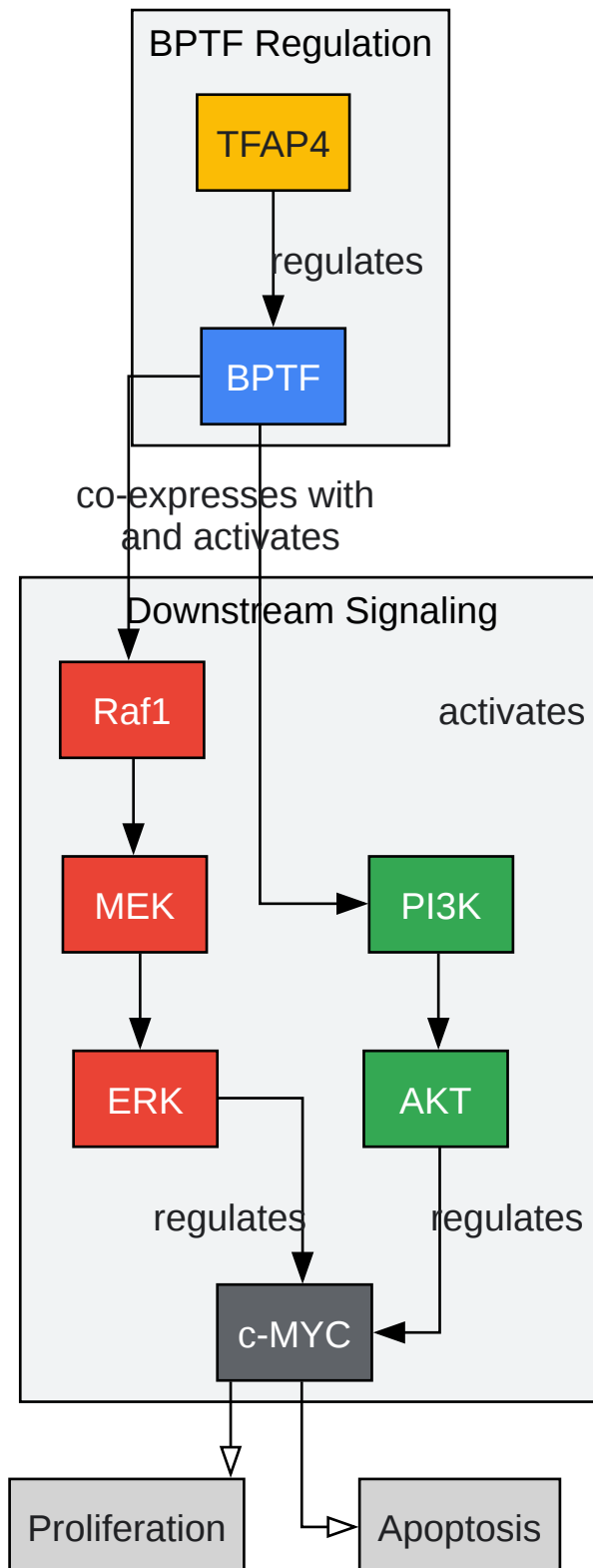

[Click to download full resolution via product page](#)

Caption: Simplified signaling pathway involving BPTF and its downstream effects.

PrOF NMR Experimental Workflow

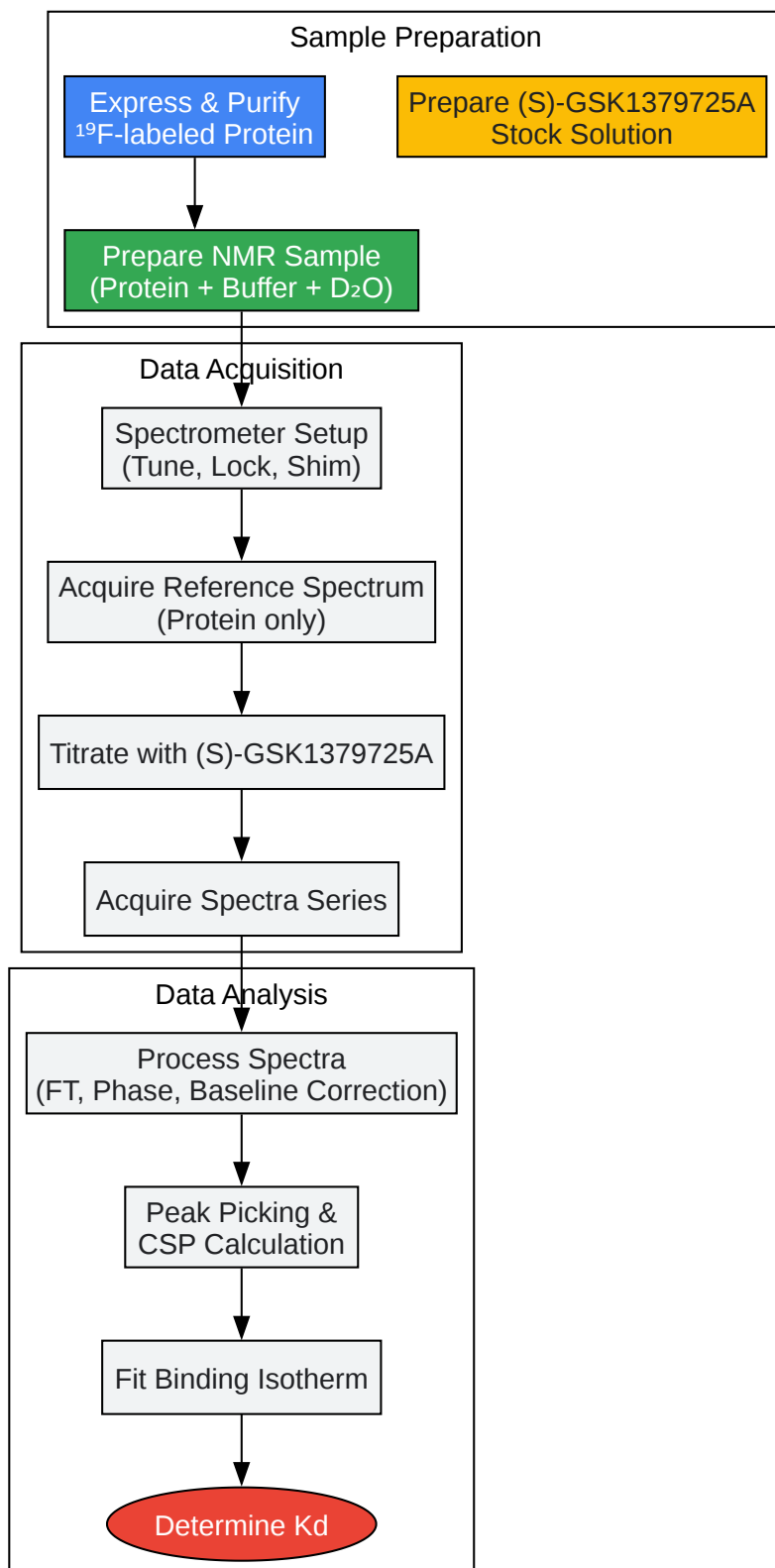

[Click to download full resolution via product page](#)

Caption: Workflow for determining Kd using PrOF NMR titration.

Troubleshooting Logic for PrOF NMR

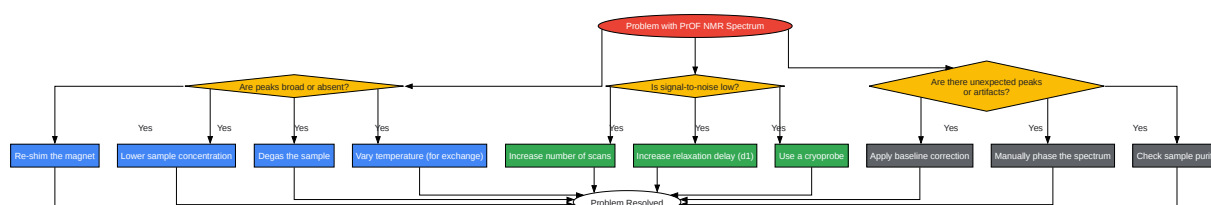

[Click to download full resolution via product page](#)

Need Custom Synthesis?

BenchChem offers custom synthesis for rare earth carbides and specific isotopic labeling.

Email: info@benchchem.com or [Request Quote Online](#).

References

1. NMR Artifacts - Max T. Rogers NMR [nmr.natsci.msu.edu]
2. Characterizing protein-glycosaminoglycan interactions using solution NMR Spectroscopy - PMC [pmc.ncbi.nlm.nih.gov]
3. F19 detection [nmr.chem.ucsb.edu]

- [4. pubs.acs.org \[pubs.acs.org\]](https://pubs.acs.org)
- [5. Automated evaluation of chemical shift perturbation spectra: New approaches to quantitative analysis of receptor-ligand interaction NMR spectra - PMC \[pmc.ncbi.nlm.nih.gov\]](#)
- [6. Using NMR Titration Experiments to study E. coli FAS-II and AcpP Mediated Protein-Protein Interactions - PMC \[pmc.ncbi.nlm.nih.gov\]](#)
- [7. Rapid Quantification of Protein-Ligand Binding via ¹⁹F NMR Lineshape Analysis - PMC \[pmc.ncbi.nlm.nih.gov\]](#)
- [8. NMR Data Processing Software | UD NMR Center \[sites.udel.edu\]](#)
- [9. Recommended Software for NMR Data Process – Georgia Tech NMR Center \[sites.gatech.edu\]](#)
- [10. NMR Software - Lancaster University \[lancaster.ac.uk\]](#)
- [11. Software – NMR Facility \[nmrservice.ch.man.ac.uk\]](#)
- [12. Using chemical shift perturbation to characterise ligand binding - PubMed \[pubmed.ncbi.nlm.nih.gov\]](#)
- [13. m.youtube.com \[m.youtube.com\]](https://m.youtube.com)
- To cite this document: BenchChem. [Technical Support Center: PrOF NMR Experiments with (S)-GSK1379725A]. BenchChem, [2026]. [Online PDF]. Available at: [\[https://www.benchchem.com/product/b15601694/docs#technical-support-center-prof-nmr-experiments-with-s-gsk1379725a\]](https://www.benchchem.com/product/b15601694/docs#technical-support-center-prof-nmr-experiments-with-s-gsk1379725a)

Disclaimer & Data Validity:

The information provided in this document is for Research Use Only (RUO) and is strictly not intended for diagnostic or therapeutic procedures. While BenchChem strives to provide accurate protocols, we make no warranties, express or implied, regarding the fitness of this product for every specific experimental setup.

Technical Support: The protocols provided are for reference purposes. Unsure if this reagent suits your experiment?

Need Industrial/Bulk Grade? [Request Custom Synthesis Quote](#)

BenchChem

Our mission is to be the trusted global source of essential and advanced chemicals, empowering scientists and researchers to drive progress in science and industry.

Contact

Address: 3281 E Guasti Rd

Ontario, CA 91761, United States

Phone: (601) 213-4426

Email: info@benchchem.com

[Contact our Ph.D. Support Team for a compatibility check](#)