

BODIPY FL C12: A Technical Guide for Cellular Lipid Analysis

Author: BenchChem Technical Support Team. **Date:** April 2026

Compound of Interest

Compound Name: *Bodipy FL C12*

Cat. No.: *B15600025*

[Get Quote](#)

For Researchers, Scientists, and Drug Development Professionals

Introduction

BODIPY FL C12 (4,4-Difluoro-5,7-Dimethyl-4-Bora-3a,4a-Diaza-s-Indacene-3-Dodecanoic Acid) is a fluorescently labeled long-chain fatty acid analog that has become an indispensable tool in cell biology for the investigation of lipid metabolism and dynamics. Its unique photophysical properties, including high fluorescence quantum yield, photostability, and sharp emission spectra, make it an excellent probe for visualizing and quantifying the uptake, trafficking, and storage of fatty acids within living and fixed cells.[1][2] The C12 lauric acid carbon chain allows it to mimic natural fatty acids, enabling its incorporation into cellular lipid pathways.[3] This technical guide provides an in-depth overview of the applications, quantitative properties, and detailed experimental protocols for the effective use of **BODIPY FL C12** in cellular research.

Core Applications in Cell Biology

BODIPY FL C12 is extensively utilized to investigate several key cellular processes:

- **Fatty Acid Uptake and Transport:** As a fluorescent analog, it allows for the real-time tracking of fatty acid entry into cells and subsequent transport across cellular membranes.[3][4] This is crucial for studying the roles of fatty acid transport proteins (FATPs) and other transporters in health and disease.
- **Lipid Droplet Dynamics:** The hydrophobic nature of **BODIPY FL C12** leads to its accumulation in lipid droplets, the primary sites of neutral lipid storage in cells.[1][5][6] This enables the visualization of lipid droplet formation, size, and distribution, providing insights into cellular energy homeostasis and lipid-related pathologies.
- **Lipid Metabolism and Esterification:** Once inside the cell, **BODIPY FL C12** is metabolized and incorporated into more complex lipids, such as triacylglycerols and phospholipids.[3] This allows researchers to study the enzymatic pathways involved in lipid synthesis and storage.
- **Membrane Imaging:** The lipophilic properties of **BODIPY FL C12** facilitate its incorporation into cellular membranes, making it a useful tool for studying membrane structure and dynamics.[1]
- **Drug Discovery and Development:** By monitoring the effects of compounds on fatty acid uptake and lipid storage, **BODIPY FL C12** serves as a valuable probe in high-throughput screening assays for the discovery of drugs targeting lipid metabolic pathways.

Quantitative Data

A clear understanding of the photophysical properties of **BODIPY FL C12** is essential for designing and interpreting fluorescence-based experiments.

Property	Value	Reference
Maximum Excitation Wavelength (λ_{ex})	~503 nm	[7]
Maximum Emission Wavelength (λ_{em})	~512 nm	[7]
Molar Extinction Coefficient (ϵ)	>80,000 $\text{cm}^{-1}\text{M}^{-1}$	[7][8]
Fluorescence Quantum Yield (Φ)	~0.9	[7]
Molecular Weight	418.34 g/mol	
Solvent for Stock Solution	DMSO	[2][7]

Experimental Protocols

Detailed methodologies are critical for obtaining reliable and reproducible results. Below are protocols for key experiments using **BODIPY FL C12**.

Protocol 1: Live-Cell Imaging of Fatty Acid Uptake and Lipid Droplet Staining

This protocol describes the staining of live cultured mammalian cells to visualize the uptake of **BODIPY FL C12** and its incorporation into lipid droplets.

Materials:

- **BODIPY FL C12**
- Dimethyl sulfoxide (DMSO)
- Phosphate-buffered saline (PBS) or Hank's Balanced Salt Solution (HBSS)
- Complete cell culture medium
- Coverslips or glass-bottom imaging dishes

- Fluorescence microscope with appropriate filter sets (e.g., FITC/GFP)

Procedure:

- Cell Seeding: Seed cells on sterile coverslips or in glass-bottom dishes at a density that will result in 70-80% confluency on the day of the experiment.
- Preparation of **BODIPY FL C12** Stock Solution: Prepare a 1-5 mM stock solution of **BODIPY FL C12** in high-quality, anhydrous DMSO. Store the stock solution at -20°C, protected from light.
- Preparation of Staining Solution: On the day of the experiment, dilute the **BODIPY FL C12** stock solution in serum-free culture medium or PBS/HBSS to a final working concentration of 1-5 µM. It is important to vortex the solution well.
- Cell Staining:
 - Remove the culture medium from the cells and wash once with warm PBS or HBSS.
 - Add the **BODIPY FL C12** staining solution to the cells and incubate for 15-30 minutes at 37°C in a CO₂ incubator, protected from light.[6]
- Washing:
 - Remove the staining solution and wash the cells two to three times with warm PBS or HBSS to remove unbound dye and reduce background fluorescence.[6]
- Imaging:
 - Add fresh, warm complete culture medium to the cells.
 - Immediately image the cells using a fluorescence microscope. Capture images using a filter set appropriate for green fluorescence (Excitation: ~490-500 nm, Emission: ~510-530 nm).

Protocol 2: Fixed-Cell Staining of Lipid Droplets

This protocol is suitable for experiments requiring cell fixation, such as co-staining with antibodies (immunofluorescence).

Materials:

- **BODIPY FL C12**
- DMSO
- PBS
- 4% Paraformaldehyde (PFA) in PBS
- Mounting medium (with or without DAPI for nuclear counterstaining)
- Coverslips and microscope slides

Procedure:

- Cell Seeding and Treatment: Seed and treat cells as described in Protocol 1.
- Fixation:
 - Wash cells once with PBS.
 - Fix the cells by incubating with 4% PFA in PBS for 15-20 minutes at room temperature.[\[6\]](#)
- Washing: Wash the cells three times with PBS for 5 minutes each to remove the fixative.
- Staining:
 - Prepare a 1-5 μ M working solution of **BODIPY FL C12** in PBS.
 - Incubate the fixed cells with the staining solution for 30-60 minutes at room temperature, protected from light.[\[6\]](#)
- Washing: Wash the cells three times with PBS for 5 minutes each.

- Mounting: Mount the coverslips onto microscope slides using an appropriate mounting medium.
- Imaging: Image the slides using a fluorescence or confocal microscope.

Protocol 3: Quantification of Fatty Acid Uptake by Flow Cytometry

This protocol allows for the quantitative analysis of **BODIPY FL C12** uptake in a cell population.

Materials:

- **BODIPY FL C12**
- DMSO
- PBS
- Cell dissociation solution (e.g., Trypsin-EDTA)
- FACS buffer (e.g., PBS with 1-2% FBS)
- Flow cytometer

Procedure:

- Cell Culture and Treatment: Culture cells in multi-well plates and perform experimental treatments as required.
- Staining:
 - Prepare a 1-5 μM working solution of **BODIPY FL C12** in serum-free medium or PBS.
 - Remove the culture medium, wash cells once with PBS, and add the staining solution.
 - Incubate for 15-30 minutes at 37°C.^[9]
- Cell Detachment:

- Wash the cells once with PBS.
- Add a cell dissociation solution and incubate until cells detach.
- Neutralize the dissociation solution with complete medium.
- Cell Collection and Washing:
 - Transfer the cell suspension to a FACS tube.
 - Centrifuge the cells at a low speed (e.g., 300 x g) for 5 minutes.
 - Discard the supernatant and wash the cell pellet twice with cold FACS buffer.
- Resuspension: Resuspend the final cell pellet in an appropriate volume of FACS buffer for analysis.
- Flow Cytometry Analysis:
 - Analyze the cells on a flow cytometer, detecting the **BODIPY FL C12** signal in the green fluorescence channel (e.g., FITC).
 - Use an unstained cell sample as a negative control to set the baseline fluorescence.

Visualizations

Cellular Fatty Acid Uptake and Metabolism Pathway

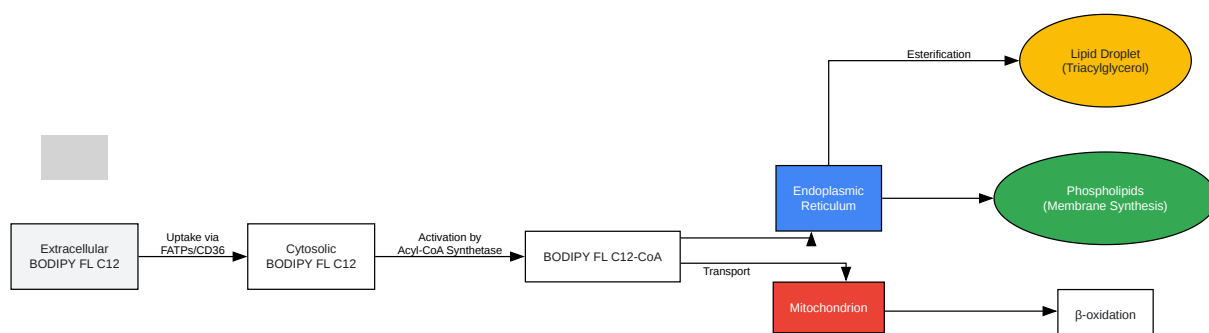

[Click to download full resolution via product page](#)

Caption: Cellular uptake and metabolic fate of **BODIPY FL C12**.

Experimental Workflow for Live-Cell Imaging

Preparation

1. Seed Cells on Imaging Dish

2. Prepare BODIPY FL C12 Stock Solution (DMSO)

3. Prepare Working Solution (1-5 μ M)

Staining

4. Wash Cells (PBS)

5. Incubate with Staining Solution (15-30 min, 37°C)

6. Wash Cells (PBS)

Imaging

7. Add Fresh Medium

8. Fluorescence Microscopy

[Click to download full resolution via product page](#)

Caption: Workflow for live-cell imaging with **BODIPY FL C12**.

Logical Flow for Flow Cytometry Analysis

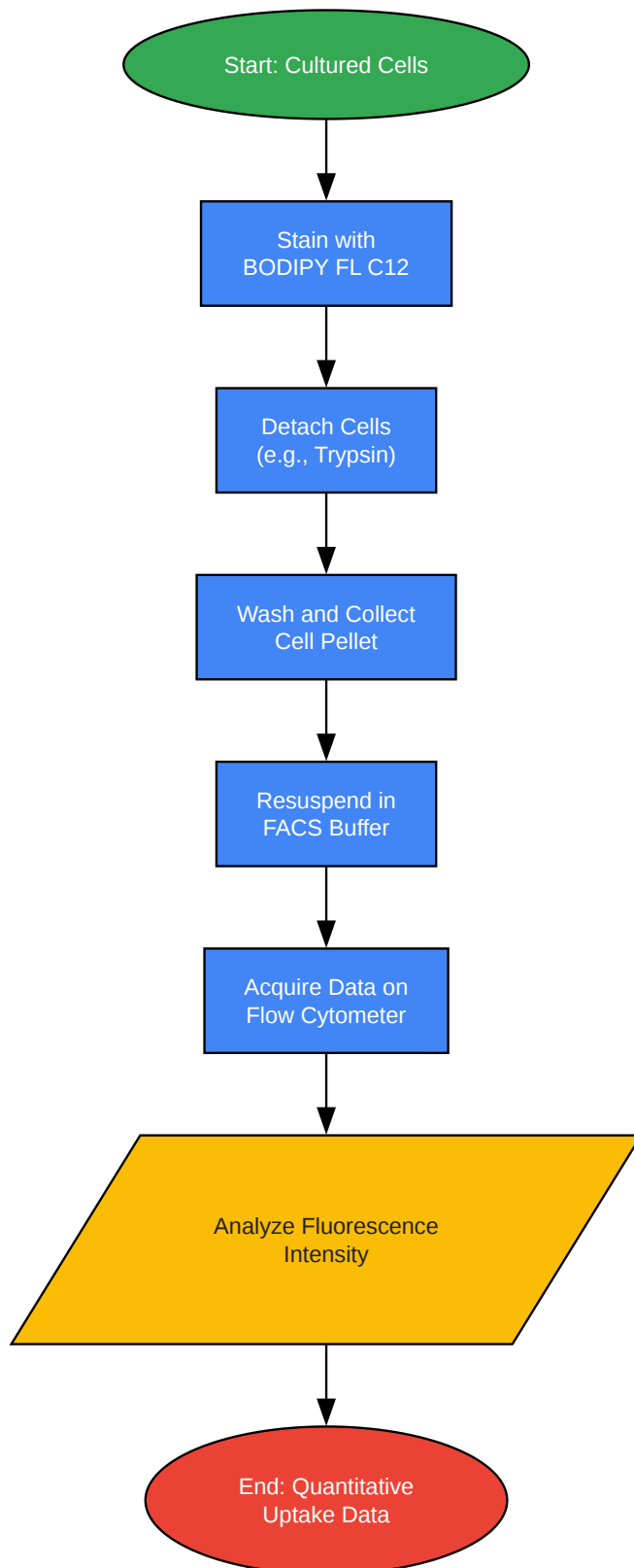

[Click to download full resolution via product page](#)

Caption: Logical flow for quantifying fatty acid uptake via flow cytometry.

Need Custom Synthesis?

BenchChem offers custom synthesis for rare earth carbides and specific isotopic labeling.

Email: info@benchchem.com or [Request Quote Online](#).

References

- [1. probes.bocsci.com \[probes.bocsci.com\]](https://probes.bocsci.com)
- [2. medchemexpress.com \[medchemexpress.com\]](https://medchemexpress.com)
- [3. Real-Time Tracking of BODIPY-C12 Long-Chain Fatty Acid in Human Term Placenta Reveals Unique Lipid Dynamics in Cytotrophoblast Cells - PMC \[pmc.ncbi.nlm.nih.gov\]](https://pubmed.ncbi.nlm.nih.gov/36111111/)
- [4. Real-Time Microscopic Assessment of Fatty Acid Uptake Kinetics in the Human Term Placenta - PMC \[pmc.ncbi.nlm.nih.gov\]](https://pubmed.ncbi.nlm.nih.gov/36111112/)
- [5. Visualizing digestive organ morphology and function using differential fatty acid metabolism in live zebrafish - PMC \[pmc.ncbi.nlm.nih.gov\]](https://pubmed.ncbi.nlm.nih.gov/36111113/)
- [6. probes.bocsci.com \[probes.bocsci.com\]](https://probes.bocsci.com)
- [7. BODIPY | AAT Bioquest \[aatbio.com\]](https://www.aatbio.com)
- [8. BODIPY Dye Series—Section 1.4 | Thermo Fisher Scientific - HK \[thermofisher.com\]](https://www.thermofisher.com)
- [9. scispace.com \[scispace.com\]](https://www.scispace.com)
- To cite this document: BenchChem. [BODIPY FL C12: A Technical Guide for Cellular Lipid Analysis]. BenchChem, [2026]. [Online PDF]. Available at: [\[https://www.benchchem.com/product/b15600025/docs#bodipy-fl-c12-a-technical-guide-for-cellular-lipid-analysis\]](https://www.benchchem.com/product/b15600025/docs#bodipy-fl-c12-a-technical-guide-for-cellular-lipid-analysis)

Disclaimer & Data Validity:

The information provided in this document is for Research Use Only (RUO) and is strictly not intended for diagnostic or therapeutic procedures. While BenchChem strives to provide accurate protocols, we make no warranties, express or implied, regarding the fitness of this product for every specific experimental setup.

Technical Support: The protocols provided are for reference purposes. Unsure if this reagent suits your experiment?

Need Industrial/Bulk Grade? [Request Custom Synthesis Quote](#)

BenchChem

Our mission is to be the trusted global source of essential and advanced chemicals, empowering scientists and researchers to drive progress in science and industry.

Contact

Address: 3281 E Guasti Rd
Ontario, CA 91761, United States
Phone: (601) 213-4426
Email: info@benchchem.com

[Contact our Ph.D. Support Team for a compatibility check](#)