

# The Mechanistic Rationale: Kinetic Isotope Effect (KIE)

**Author:** BenchChem Technical Support Team. **Date:** April 2026

## Compound of Interest

Compound Name: *trans-4-Phenyl-3-buten-2-one-1,1,1,3-d4*  
CAS No.: 130208-38-7  
Cat. No.: B156468

[Get Quote](#)

The primary rationale for deuterating chalcones is to fortify the molecule against rapid Phase I metabolism[1]. The carbon-deuterium (C-D) bond possesses a lower zero-point vibrational energy than the carbon-hydrogen (C-H) bond, making it significantly stronger and more resistant to cleavage by cytochrome P450 enzymes[2].

By selectively deuterating the  $\alpha,\beta$ -unsaturated moiety or metabolically vulnerable aromatic positions, we decelerate oxidative metabolism without altering the molecule's steric or electronic footprint. This targeted stabilization directly translates to an extended elimination half-life ( $t_{1/2}$ ) and a greater Area Under the Curve (AUC)[2].

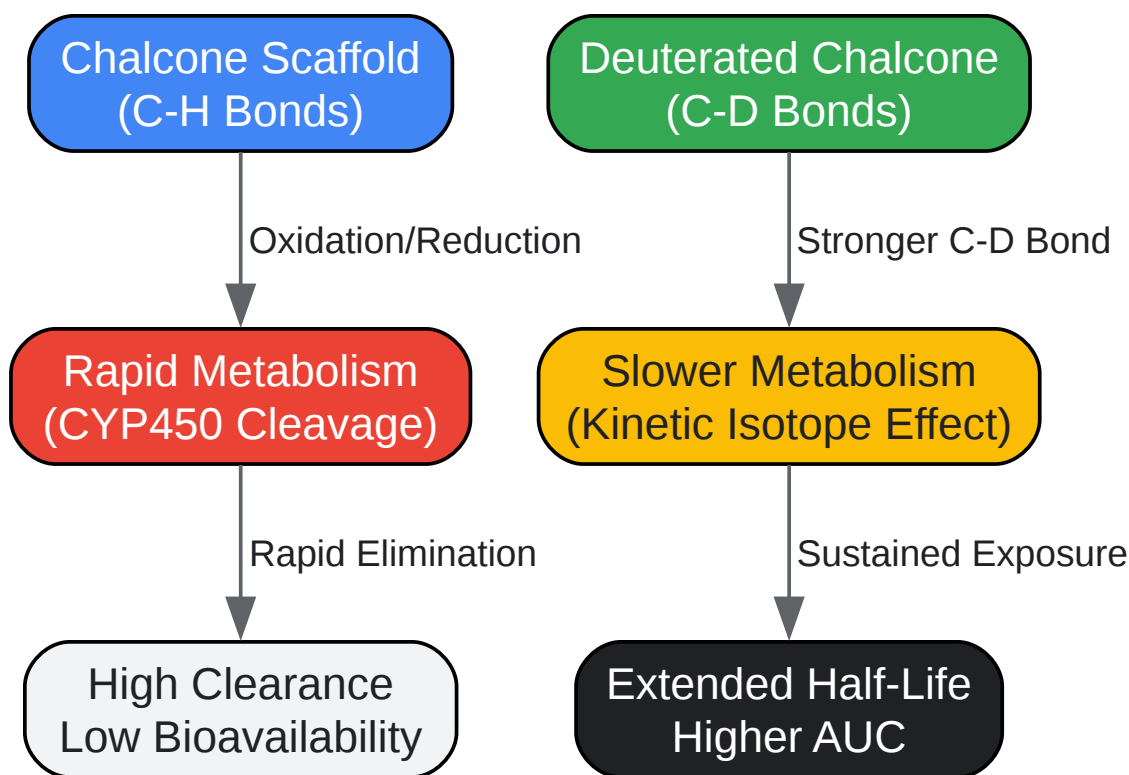

[Click to download full resolution via product page](#)

Caption: Kinetic isotope effect on chalcone metabolism, demonstrating extended half-life and higher AUC.

## Synthetic Methodologies: Overcoming Over-Reduction

Synthesizing deuterated chalcones presents a distinct chemoselectivity challenge. Traditional batch deuteration (e.g., using D<sub>3</sub>PO<sub>4</sub> and AcOD) is effective for incorporating deuterium at the C-3 position of flavanones via enolization[3]. However, when targeting the open-chain chalcone, the  $\alpha,\beta$ -unsaturated carbonyl system is highly prone to over-reduction, often yielding fully saturated ketones or alcohols[4].

To solve this, continuous-flow chemistry has emerged as the definitive standard. Utilizing an electrolytic flow reactor (such as the H-Cube® system), we can achieve highly controlled, partial C≡C bond deuteration of 1,3-diphenylalkynone precursors[4]. This approach generates D<sub>2</sub> gas on-demand via the electrolysis of D<sub>2</sub>O, eliminating the safety hazards of pressurized D<sub>2</sub> cylinders while maximizing isotopic efficiency[4].

## Data Presentation: Optimization of Continuous-Flow Deuteration

The delicate balance between target selectivity and reaction rate is governed by system pressure. Table 1 summarizes the optimization data for the continuous-flow deuteration of antidiabetic alkyne precursors.

Table 1: Continuous-Flow Deuteration of Alkynes (Pd/C Catalyst, 30 °C)

System Pressure	Total Conversion	Dideuteroenone (Target)	Tetradeterone (Side Product)	Pentadeuteroalcohol
10 bar	32%	95%	5%	0%
20 bar	57%	86%	14%	0%

| 50 bar | 89% | 62% | 38% | Trace |

Insight: Operating at 20 bar provides the optimal thermodynamic environment, balancing a practical 57% conversion rate with an excellent 86:14 target-to-side-product ratio, completely avoiding the irreversible formation of pentadeuteroalcohols[4].

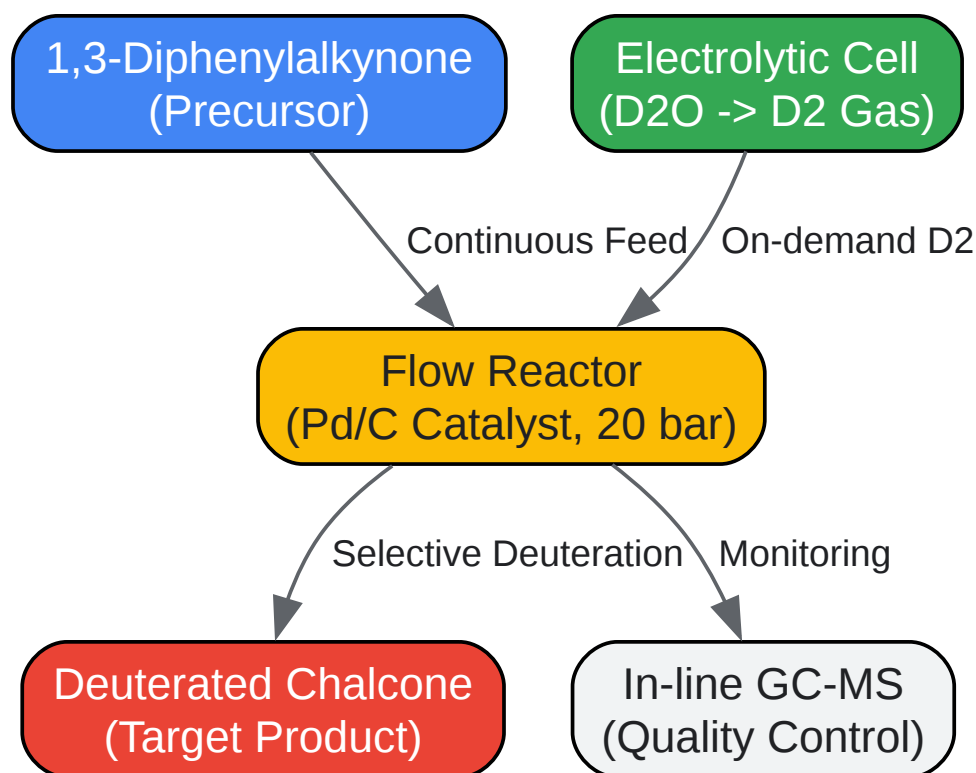

[Click to download full resolution via product page](#)

Caption: Continuous-flow synthesis workflow for selective alkyne deuteration using an electrolytic reactor.

## Self-Validating Experimental Protocols

To ensure absolute reproducibility and scientific rigor, the following protocols are designed as self-validating systems, incorporating mandatory quality control checkpoints.

### Protocol A: Continuous-Flow Synthesis of Dideuterochalcones

Causality: Continuous flow restricts the residence time of the substrate on the catalyst bed, physically preventing the over-reduction cascade that plagues batch reactors[4].

- Precursor Preparation: Dissolve the 1,3-diphenylalkynone precursor in anhydrous ethyl acetate to yield a 0.05 M solution.

- System Initialization: Equip the flow reactor with a 5% Pd/C catalyst cartridge. Fill the electrolytic cell reservoir with high-purity D<sub>2</sub>O (>99.8% D)[4].
- Parameter Setting: Set the system pressure strictly to 20 bar and the temperature to 30 °C. Adjust the liquid flow rate to 1.0 mL/min.
- Execution & In-Line Validation: Pump the precursor solution through the reactor. Divert a 1% fraction of the eluate to an in-line GC-MS to continuously validate the 86:14 (target:byproduct) steady-state ratio.
- Isolation: Collect the main eluate. Note: The heterogeneous catalysis initially forms the (Z)-deuterated chalcone isomer, which will spontaneously undergo thermal/photochemical isomerization to the thermodynamically stable (E)-form upon exposure to ambient light and purification[4].
- Purification: Isolate the pure (E)-dideuteroenone via flash column chromatography to remove the tetradeuteroketone fraction.

## Protocol B: Comparative In Vivo Pharmacokinetic Profiling

Causality: A head-to-head PK study in a rodent model is mandatory to empirically quantify the magnitude of the KIE on systemic clearance[2].

- Subject Preparation: Fast male Sprague-Dawley rats (200-250 g, n=6 per group) overnight to eliminate food-drug absorption variables, ensuring ad libitum access to water[2].
- Formulation: Suspend the non-deuterated and deuterated chalcone analogs separately in a vehicle of 0.5% carboxymethyl cellulose (CMC) in water[2].
- Administration: Administer a single 10 mg/kg dose via oral gavage to Group A (non-deuterated) and Group B (deuterated)[2].
- Sampling: Collect serial blood samples (200 µL) via jugular vein cannulation at 0, 0.25, 0.5, 1, 2, 4, 8, 12, and 24 hours post-dose into heparinized tubes[2].

- Bioanalytical Validation: Centrifuge samples to isolate plasma. Extract analytes via acetonitrile protein precipitation. Quantify using a validated LC-MS/MS method, utilizing a structurally distinct internal standard to validate extraction recovery.
- Data Derivation: Calculate PK parameters (  $C_{max}$ ,  $T_{max}$ , AUC,  $t_{1/2}$ , and  $CL/F$  ) using non-compartmental analysis. A successful "deuterium switch" is validated by a statistically significant decrease in  $CL/F$  and an increase in AUC for Group B[2].

## Conclusion

The strategic deuteration of the chalcone scaffold represents a highly effective methodology for overcoming the inherent metabolic liabilities of this bioactive class. By transitioning from traditional batch methods to advanced continuous-flow electrolytic systems, researchers can achieve precise chemoselectivity, yielding stable, isotopically labeled candidates. When coupled with rigorous, self-validating pharmacokinetic profiling, deuterated chalcones offer a highly promising avenue for next-generation drug development.

## References

- Ötvös, S. B., Hsieh, C.-T., Wu, Y.-C., Li, J.-H., Chang, F.-R., & Fülöp, F. "Continuous-Flow Synthesis of Deuterium-Labeled Antidiabetic Chalcones: Studies towards the Selective Deuteration of the Alkynone Core." *Molecules*, 21(3), 318, 2016. URL:[[Link](#)]
- Kagawa, H., Takahashi, T., Uno, M., Ohta, S., & Harigaya, Y. "Synthesis of Deuterium-Labeled Flavanones." *Chemical and Pharmaceutical Bulletin*, 52(8), 953-956, 2004. URL: [[Link](#)]

### Need Custom Synthesis?

BenchChem offers custom synthesis for rare earth carbides and specific isotopic labeling.

Email: [info@benchchem.com](mailto:info@benchchem.com) or [Request Quote Online](#).

## Sources

- 1. [pdf.benchchem.com](https://pdf.benchchem.com) [[pdf.benchchem.com](https://pdf.benchchem.com)]
- 2. [pdf.benchchem.com](https://pdf.benchchem.com) [[pdf.benchchem.com](https://pdf.benchchem.com)]

- [3. scispace.com \[scispace.com\]](https://scispace.com)
- [4. Continuous-Flow Synthesis of Deuterium-Labeled Antidiabetic Chalcones: Studies towards the Selective Deuteration of the Alkynone Core - PMC \[pmc.ncbi.nlm.nih.gov\]](https://pubmed.ncbi.nlm.nih.gov/)
- To cite this document: BenchChem. [The Mechanistic Rationale: Kinetic Isotope Effect (KIE)]. BenchChem, [2026]. [Online PDF]. Available at: [\[https://www.benchchem.com/product/b156468/docs#the-mechanistic-rationale-kinetic-isotope-effect-kie\]](https://www.benchchem.com/product/b156468/docs#the-mechanistic-rationale-kinetic-isotope-effect-kie)

---

**Disclaimer & Data Validity:**

The information provided in this document is for Research Use Only (RUO) and is strictly not intended for diagnostic or therapeutic procedures. While BenchChem strives to provide accurate protocols, we make no warranties, express or implied, regarding the fitness of this product for every specific experimental setup.

**Technical Support:** The protocols provided are for reference purposes. Unsure if this reagent suits your experiment?

**Need Industrial/Bulk Grade?** [Request Custom Synthesis Quote](#)

## BenchChem

Our mission is to be the trusted global source of essential and advanced chemicals, empowering scientists and researchers to drive progress in science and industry.

### Contact

Address: 3281 E Guasti Rd  
Ontario, CA 91761, United States  
Phone: (601) 213-4426  
Email: [info@benchchem.com](mailto:info@benchchem.com)

[Contact our Ph.D. Support Team for a compatibility check](#)

