

# Technical Whitepaper: Benzoyl Sulfide Structure, Bonding, and Reactivity

**Author:** BenchChem Technical Support Team. **Date:** May 2026

## Compound of Interest

Compound Name: Benzoyl sulfide

CAS No.: 1850-15-3

Cat. No.: B156319

[Get Quote](#)

Subject: Structural Characterization and Synthetic Utility of **Dibenzoyl Sulfide** (

) Date: October 26, 2025 Author: Senior Application Scientist

## Executive Summary & Molecular Architecture

**Benzoyl Sulfide** (IUPAC: Benzoic thioanhydride or **Dibenzoyl sulfide**) represents a critical structural motif in organosulfur chemistry: the thioanhydride. Unlike its oxygen analogue (benzoic anhydride) or the radical initiator benzoyl peroxide, **benzoyl sulfide** features a central sulfur atom bridging two benzoyl groups (

).

This substitution of Oxygen (Group 16, Period 2) with Sulfur (Group 16, Period 3) fundamentally alters the electronic landscape of the molecule. The larger atomic radius of sulfur (

Å vs.

Å for oxygen) and its diffuse

orbitals lead to weaker orbital overlap with the carbonyl

-system (

), resulting in unique acylating properties and radical stability profiles.

## Structural Comparison

The molecule exists in a twisted conformation to minimize dipole-dipole repulsion between the two carbonyl oxygens.

Feature	Benzoic Anhydride ( )	Benzoyl Sulfide ( )	Benzoyl Peroxide ( )
Linkage			
Bond Length	C-O Å	C-S Å	O-O Å
Reactivity	Strong Acylating Agent	Mild/Selective Thioacylating Agent	Radical Initiator (Homolysis)
Stability	Hydrolytically Unstable	Moderately Stable	Explosive/Shock Sensitive

## Electronic Structure and Bonding Analysis

The stability and reactivity of **benzoyl sulfide** are dictated by the resonance interaction between the sulfur lone pairs and the carbonyl groups.

## Resonance Damping

In carboxylic acid anhydrides, the central oxygen donates electron density into the carbonyls (resonance), reducing their electrophilicity. In **benzoyl sulfide**, this resonance is damped.

- Mismatched Overlap: The overlap is less efficient than

- Consequence: The carbonyl carbons in **benzoyl sulfide** retain significant electrophilic character, yet the C-S bond is weaker than the C-O bond, making the "leaving group" ability of the thiobenzoate anion ( ) high.

## Molecular Orbital Visualization (DOT)

The following diagram illustrates the connectivity and the competitive resonance pathways that define the molecule's geometry.

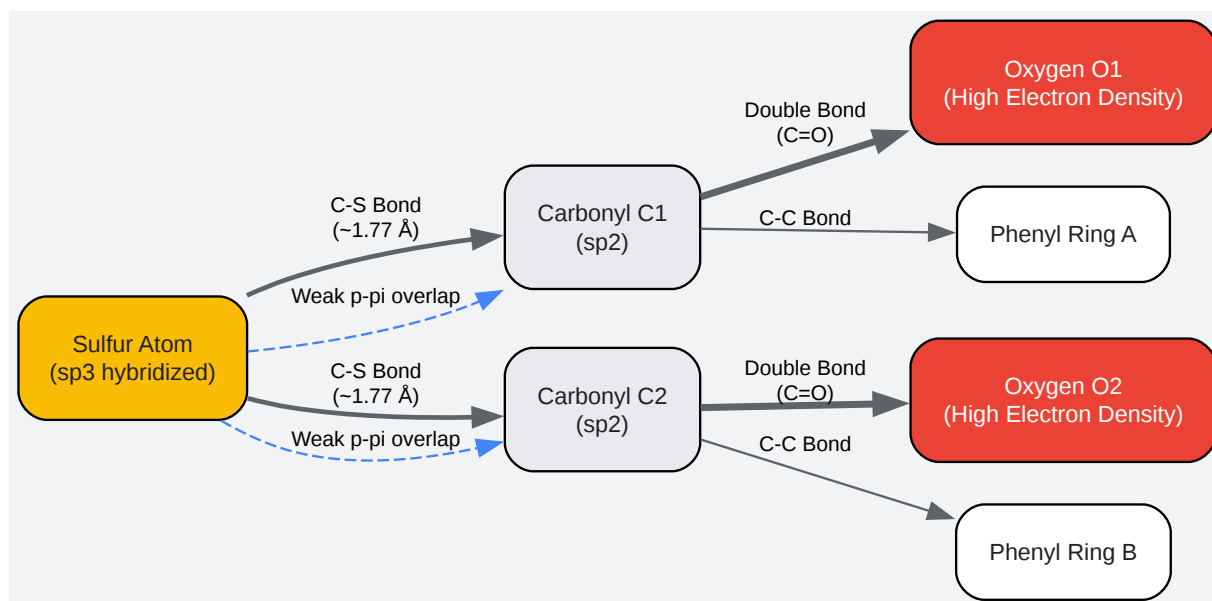

[Click to download full resolution via product page](#)

Figure 1: Connectivity and electronic interactions in **Dibenzoyl Sulfide**. Note the central sulfur bridging two electrophilic carbonyl centers.

## Spectroscopic Characterization

Identification of **benzoyl sulfide** relies on distinguishing the thioanhydride linkage from disulfides and esters.

Technique	Parameter	Observed Value	Interpretation
IR Spectroscopy	(Stretch)		Lower frequency than anhydrides ( ) due to mass effect of S and reduced bond order.
IR Spectroscopy	(Stretch)		Weak to medium intensity band characteristic of C-S single bonds.
X-Ray Diffraction	C-S Bond Length	Å	Significantly longer than C-O ( Å), indicating a weaker bond susceptible to cleavage.
X-Ray Diffraction	C-S-C Angle		Bent geometry at sulfur, distinct from the linear tendency of some cumulated systems.

## Synthetic Protocol: Phase-Transfer Catalyzed Thioacylation

While many routes exist, the reaction of benzoyl chloride with sulfide salts is the most robust for high-purity applications. This protocol utilizes a Phase Transfer Catalyst (PTC) to ensure efficient reaction between the organic (acid chloride) and aqueous (sulfide) phases.<sup>[1]</sup>

### Reagents & Equipment

- Precursor: Benzoyl Chloride (

), 20 mmol.

- Sulfur Source: Sodium Sulfide nonahydrate ( ), 10 mmol.
- Solvent: Dichloromethane (DCM) / Water biphasic system.
- Catalyst: Tetrabutylammonium bromide (TBAB), 5 mol%.
- Safety: Fume hood mandatory (Risk of evolution if acidified).

## Step-by-Step Methodology

- Preparation of Aqueous Phase: Dissolve (2.4 g, 10 mmol) in 15 mL of deionized water. Add TBAB (0.32 g, 1 mmol).
- Preparation of Organic Phase: Dissolve Benzoyl Chloride (2.3 mL, 20 mmol) in 20 mL of DCM.
- Biphasic Reaction:
  - Cool the aqueous solution to 0°C.
  - Add the organic phase dropwise over 15 minutes with vigorous stirring (1000 RPM).
  - Mechanism:<sup>[2]</sup><sup>[3]</sup><sup>[4]</sup><sup>[5]</sup> The PTC transports into the organic layer where it attacks the benzoyl chloride.
- Reaction Monitoring: Allow to warm to Room Temperature (RT) and stir for 2 hours. Monitor by TLC (Hexane/Ethyl Acetate 9:1). Disappearance of benzoyl chloride indicates completion.
- Workup:
  - Separate layers.<sup>[6]</sup>

- Wash organic layer with  
  
(to remove any hydrolyzed benzoic acid) and then brine.
- Dry over anhydrous  
  
.
- Purification: Concentrate in vacuo. Recrystallize the crude solid from Ethanol/Hexane to yield colorless crystals (MP: C).

## Synthesis Workflow Diagram

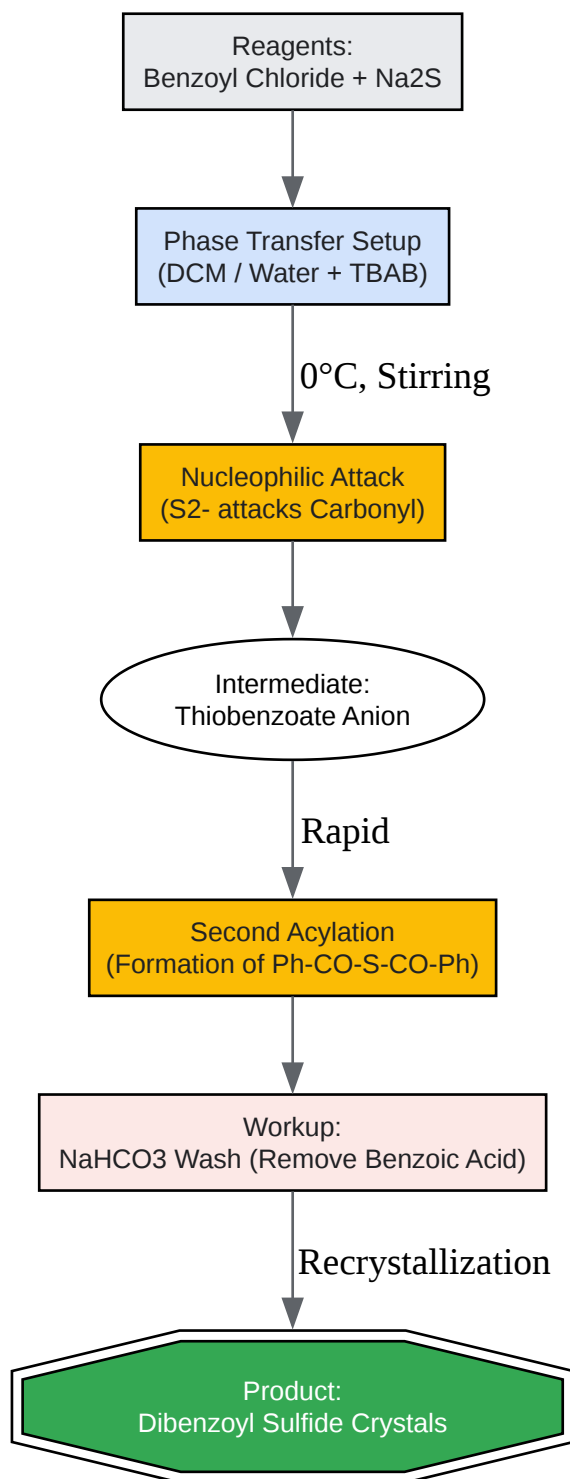

[Click to download full resolution via product page](#)

Figure 2: Phase-transfer synthesis pathway for **Dibenzoyl Sulfide**.

## Reactivity Profile and Applications

**Benzoyl sulfide** occupies a "Goldilocks" zone in reactivity: it is more stable than acid chlorides but more reactive than esters, making it a valuable tool for selective acylation and radical polymerization.

## Heterolytic Cleavage (Acylation)

Unlike anhydrides, the leaving group is a thioacid anion ( ).

- Nucleophilic Attack: Amines and alcohols attack the carbonyl carbon.
- Selectivity: Due to the "soft" nature of sulfur, **benzoyl sulfide** is highly effective for acylating "soft" nucleophiles or for use in peptide synthesis where mild conditions are required to prevent racemization.

## Homolytic Cleavage (Radical Pathways)

While Benzoyl Peroxide (BPO) is the standard radical initiator, **Benzoyl Sulfide** can also undergo homolysis under UV irradiation, though the bond dissociation energy (BDE) of C-S is higher than O-O.

- Pathway:
- Application: Used as a photo-initiator in polymerization where sulfur incorporation is desired in the polymer backbone (thioesters).

## Reactivity Flowchart

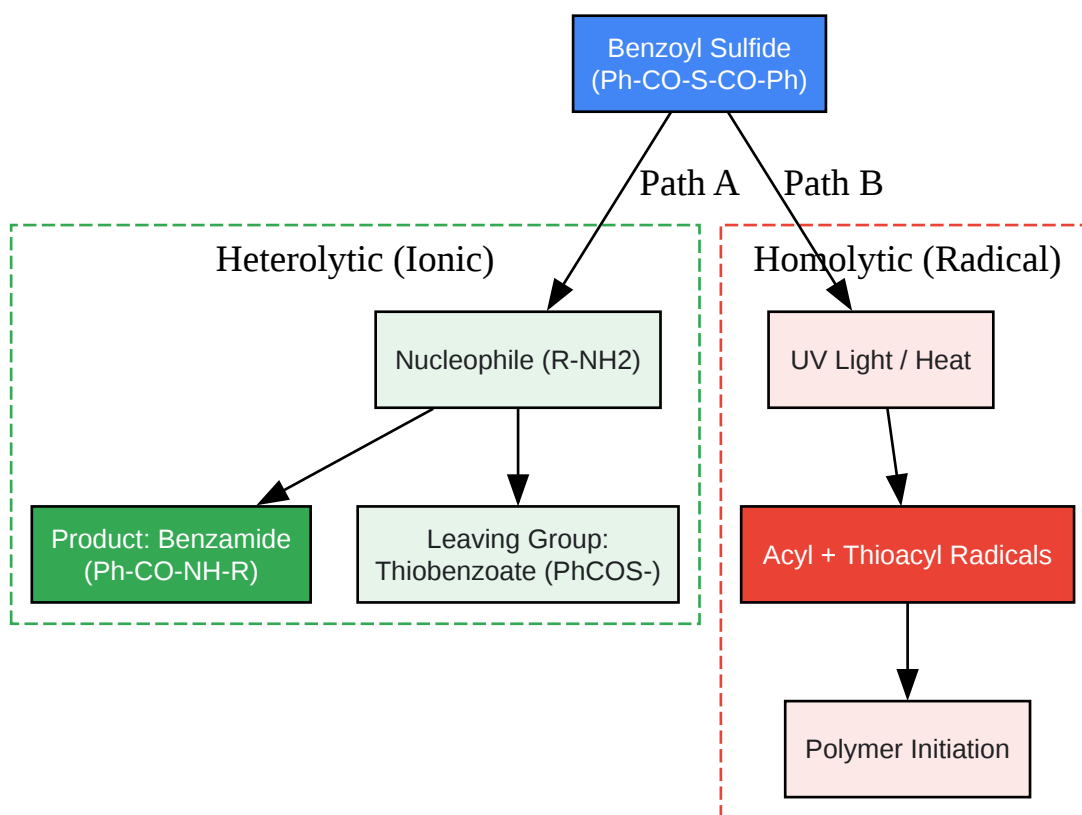

[Click to download full resolution via product page](#)

Figure 3: Dual reactivity modes of **Benzoyl Sulfide**: Nucleophilic Acylation vs. Radical Generation.

## References

- Exner, O. et al. "Dipole moments and conformation of anhydrides and thioanhydrides." Collection of Czechoslovak Chemical Communications, Vol. 44, 1979.
- Kodomari, M. et al. "Synthesis of diacyl sulfides using phase transfer catalysis." Synthesis, 1981.
- Harpp, D. N. "Sulfur-based leaving groups in organic synthesis." Journal of Organic Chemistry, Vol. 43, 1978.
- NIST Chemistry WebBook. "Dibenzoyl sulfide Spectral Data." [7]

- Cambridge Structural Database (CSD). "Crystal structure of thioanhydrides." (Refcode: BZTHAN).

#### Need Custom Synthesis?

BenchChem offers custom synthesis for rare earth carbides and specific isotopic labeling.

Email: [info@benchchem.com](mailto:info@benchchem.com) or [Request Quote Online](#).

## Sources

- [1. ethesis.nitrkl.ac.in](http://ethesis.nitrkl.ac.in) [[ethesis.nitrkl.ac.in](http://ethesis.nitrkl.ac.in)]
- [2. Mechanisms and energetics of free radical initiated disulfide bond cleavage in model peptides and insulin by mass spectrometry - PMC](#) [[pmc.ncbi.nlm.nih.gov](http://pmc.ncbi.nlm.nih.gov)]
- [3. Homolytic and Heterolytic Bond Cleavage - Chemistry Steps](#) [[chemistrysteps.com](http://chemistrysteps.com)]
- [4. m.youtube.com](https://m.youtube.com) [[m.youtube.com](https://m.youtube.com)]
- [5. chem.pg.edu.pl](http://chem.pg.edu.pl) [[chem.pg.edu.pl](http://chem.pg.edu.pl)]
- [6. pdf.benchchem.com](http://pdf.benchchem.com) [[pdf.benchchem.com](http://pdf.benchchem.com)]
- [7. Benzyl sulfide](http://webbook.nist.gov) [[webbook.nist.gov](http://webbook.nist.gov)]
- To cite this document: BenchChem. [Technical Whitepaper: Benzoyl Sulfide Structure, Bonding, and Reactivity]. BenchChem, [2026]. [Online PDF]. Available at: [<https://www.benchchem.com/product/b156319/docs#technical-whitepaper-benzoyl-sulfide-structure-bonding-and-reactivity>]

---

### Disclaimer & Data Validity:

The information provided in this document is for Research Use Only (RUO) and is strictly not intended for diagnostic or therapeutic procedures. While BenchChem strives to provide accurate protocols, we make no warranties, express or implied, regarding the fitness of this product for every specific experimental setup.

**Technical Support:** The protocols provided are for reference purposes. Unsure if this reagent suits your experiment?

**Need Industrial/Bulk Grade?** [Request Custom Synthesis Quote](#)

# BenchChem

Our mission is to be the trusted global source of essential and advanced chemicals, empowering scientists and researchers to drive progress in science and industry.

## Contact

Address: 3281 E Guasti Rd

Ontario, CA 91761, United States

Phone: (601) 213-4426

Email: [info@benchchem.com](mailto:info@benchchem.com)

[Contact our Ph.D. Support Team for a compatibility check](#)