

An In-Depth Technical Guide to the Spectroscopic Characterization of *tert*-Butyldiphenylmethanol

Author: BenchChem Technical Support Team. **Date:** May 2026

Compound of Interest

Compound Name:	<i>tert</i> -Butyldiphenylmethanol
CAS No.:	1657-60-9
Cat. No.:	B156343

[Get Quote](#)

This guide provides a comprehensive analysis of the core spectroscopic techniques used to elucidate and confirm the structure of ***tert*-butyldiphenylmethanol**. Designed for researchers, scientists, and professionals in drug development, this document moves beyond raw data to offer insights into the causal relationships between molecular structure and spectral output. We will explore the principles behind the observed data, establish self-validating experimental protocols, and integrate multi-technique analysis for unambiguous structural confirmation.

Introduction to *tert*-Butyldiphenylmethanol

***Tert*-butyldiphenylmethanol** is a tertiary alcohol characterized by a central carbinol carbon bonded to two phenyl groups and one bulky *tert*-butyl group. This unique sterically hindered structure influences its reactivity and presents a distinct spectroscopic fingerprint. Accurate characterization is paramount for its use in synthesis, mechanistic studies, and as a potential building block in medicinal chemistry. This guide details the expected outcomes from Nuclear Magnetic Resonance (NMR) spectroscopy (^1H and ^{13}C), Infrared (IR) Spectroscopy, and Mass Spectrometry (MS), providing a robust framework for its identification.

Section 1: Nuclear Magnetic Resonance (NMR) Spectroscopy

NMR spectroscopy is the cornerstone of molecular structure elucidation, providing detailed information about the hydrogen and carbon framework. For **tert-butyldiphenylmethanol**, both ^1H and ^{13}C NMR offer unique and complementary data points.

^1H NMR Spectroscopy: Mapping the Proton Environment

The proton NMR spectrum of **tert-butyldiphenylmethanol** is defined by three distinct regions corresponding to the aromatic, hydroxyl, and aliphatic protons. The symmetry of the two phenyl groups and the free rotation of the tert-butyl group simplify the overall pattern.

Data Interpretation and Causality:

- Aromatic Protons (δ ~7.2-7.5 ppm):** The ten protons on the two phenyl rings are electronically similar, resulting in a complex, overlapping multiplet in the typical aromatic region. Their downfield shift is a direct consequence of the deshielding effect of the benzene ring current.
- Hydroxyl Proton (δ ~2.1 ppm):** The chemical shift of the -OH proton is variable and depends on concentration, solvent, and temperature due to hydrogen bonding. It typically appears as a broad singlet. Its integration value of 1H is a key identifier.
- tert-Butyl Protons (δ ~1.1 ppm):** The nine protons of the tert-butyl group are chemically equivalent due to rapid rotation around the C-C single bonds. This equivalence results in a sharp, strong singlet. Its upfield chemical shift is characteristic of shielded, aliphatic protons, and its integration to 9H is an unmistakable marker for the tert-butyl moiety.

Table 1: Summary of ^1H NMR Data for **tert-Butyldiphenylmethanol**

Predicted Chemical Shift (δ , ppm)	Multiplicity	Integration	Assignment
~7.2-7.5	Multiplet	10H	Aromatic (C_6H_5) ₂
~2.1	Singlet (broad)	1H	Hydroxyl (-OH)

| ~1.1 | Singlet | 9H | tert-Butyl (-C(CH₃)₃) |

¹³C NMR Spectroscopy: Probing the Carbon Skeleton

The proton-decoupled ¹³C NMR spectrum provides a count of the unique carbon environments within the molecule. The symmetry of **tert-butyldiphenylmethanol** simplifies the aromatic region.

Data Interpretation and Causality:

- **Aromatic Carbons:** Four distinct signals are expected for the two phenyl groups. The ipso-carbon (the one attached to the carbinol center) is shifted downfield (~147 ppm). The ortho, meta, and para carbons will appear in the typical aromatic window of ~125-128 ppm.
- **Carbinol Carbon (C-OH):** This quaternary carbon is significantly deshielded by the attached oxygen and phenyl groups, causing it to appear downfield (~80 ppm).
- **tert-Butyl Carbons:** Two signals represent the tert-butyl group: the quaternary carbon directly attached to the carbinol center (~39 ppm) and the three equivalent methyl carbons, which appear further upfield (~27 ppm).

Table 2: Summary of ¹³C NMR Data for **tert-Butyldiphenylmethanol**

Predicted Chemical Shift (δ, ppm)	Assignment
~147	ipso-Aromatic C
~128	ortho/meta/para-Aromatic CH
~80	Carbinol C-OH
~39	Quaternary C of tert-butyl

| ~27 | Methyl C of tert-butyl |

Section 2: Infrared (IR) Spectroscopy

IR spectroscopy probes the vibrational frequencies of functional groups. The spectrum of **tert-butyldiphenylmethanol** is dominated by absorptions from the hydroxyl group, the aromatic

rings, and the aliphatic tert-butyl group.

Data Interpretation and Causality:

- **O-H Stretch:** A strong, broad absorption band appears around 3600-3200 cm^{-1} . The broadening is a classic indicator of intermolecular hydrogen bonding between alcohol molecules.
- **C-H Stretches (Aromatic & Aliphatic):** Aromatic C-H stretches appear as a series of sharp bands just above 3000 cm^{-1} (typically 3100-3000 cm^{-1}). Aliphatic C-H stretches from the tert-butyl group appear just below 3000 cm^{-1} (typically 2950-2850 cm^{-1}). This clear demarcation is highly diagnostic.
- **C=C Stretch (Aromatic):** Overtones and combination bands characteristic of aromatic rings are observed in the 1600-1450 cm^{-1} region.
- **C-O Stretch:** A strong band corresponding to the C-O stretching vibration of the tertiary alcohol is expected in the 1200-1100 cm^{-1} region.

Table 3: Key IR Absorption Bands for **tert-Butyldiphenylmethanol**

Wavenumber (cm^{-1})	Intensity	Vibrational Mode	Functional Group
~3500	Strong, Broad	O-H Stretch	Hydroxyl (-OH)
3100-3000	Medium, Sharp	C-H Stretch	Aromatic C-H
2950-2850	Strong, Sharp	C-H Stretch	Aliphatic C-H
1600, 1490, 1450	Medium-Weak	C=C Stretch (in-ring)	Aromatic

| ~1150 | Strong | C-O Stretch | Tertiary Alcohol |

Section 3: Mass Spectrometry (MS)

Electron Ionization Mass Spectrometry (EI-MS) provides information about the molecular weight and fragmentation pattern of a molecule, offering crucial clues to its structure. Due to

the stability of carbocations that can be formed, **tert-butyl diphenylmethanol** exhibits a highly predictable fragmentation pathway.

Data Interpretation and Causality: The molecular ion (M^+) peak is often weak or absent in the EI spectrum of tertiary alcohols due to the ease of fragmentation. The most significant fragmentation event is the α -cleavage, specifically the loss of the bulky tert-butyl group.

- **Loss of tert-Butyl Group:** The cleavage of the bond between the carbinol carbon and the tert-butyl group results in the loss of a tert-butyl radical ($\bullet C(CH_3)_3$, 57 Da). This generates the diphenylmethyl cation ($[(C_6H_5)_2COH]^+$), which is highly stabilized by resonance across the two phenyl rings. This fragment is often the base peak in the spectrum.
- **Other Fragments:** Further fragmentation of the phenyl groups can lead to smaller ions, but the loss of the tert-butyl group is the dominant and most diagnostic pathway.

Table 4: Predicted Mass Spectrometry Data for **tert-Butyl diphenylmethanol** (M.W. = 242.34)

m/z	Proposed Fragment	Significance
242	$[C_{17}H_{20}O]^+$	Molecular Ion (M^+) - May be weak or absent
185	$[(C_6H_5)_2COH]^+$	M - 57 (Loss of $\bullet C(CH_3)_3$) - Often the base peak
105	$[C_6H_5CO]^+$	Benzoyl cation
77	$[C_6H_5]^+$	Phenyl cation

| 57 | $[C(CH_3)_3]^+$ | tert-Butyl cation |

Visualization of Key Fragmentation Pathway

The primary fragmentation pathway is visualized below, highlighting the formation of the resonance-stabilized diphenylmethyl cation.

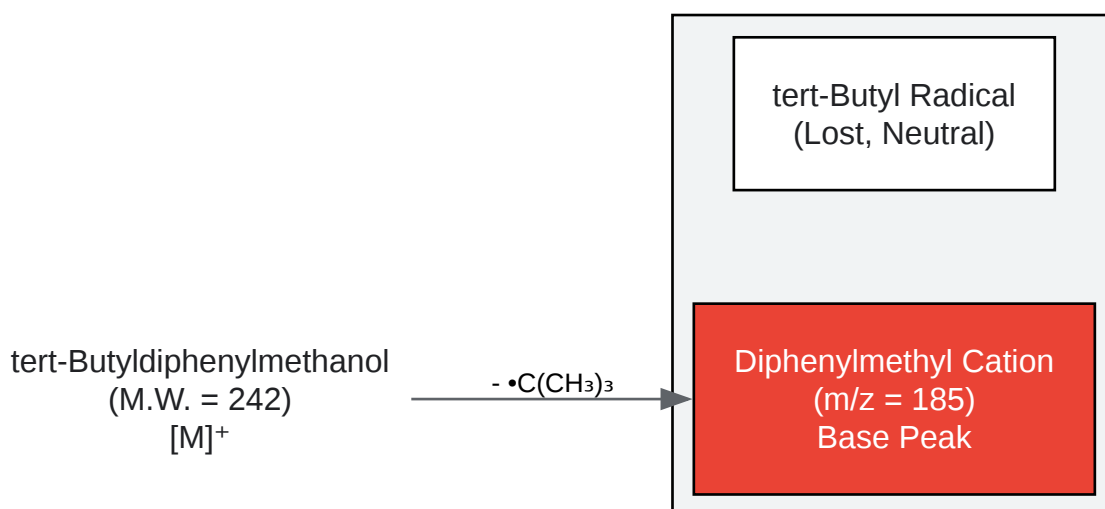

[Click to download full resolution via product page](#)

Caption: Primary EI-MS fragmentation of **tert-butyl diphenylmethanol**.

Section 4: Experimental Protocols & Integrated Workflow

Achieving high-quality, reproducible data requires robust and well-validated experimental protocols. The following are generalized procedures for the spectroscopic analysis of **tert-butyl diphenylmethanol**.

Protocol 1: NMR Sample Preparation and Acquisition

- Objective: To obtain high-resolution ¹H and ¹³C NMR spectra.
- Methodology:
 - Sample Preparation: Accurately weigh 5-10 mg of dry **tert-butyl diphenylmethanol** and dissolve it in ~0.7 mL of a deuterated solvent (e.g., CDCl₃) in a clean, dry NMR tube.
 - Scientist's Note: CDCl₃ is a good first choice as it is aprotic and dissolves many organic compounds. The residual CHCl₃ peak at 7.26 ppm (¹H) and the solvent triplet at 77.16 ppm (¹³C) serve as convenient internal references.

- Add Internal Standard: Add a small amount of tetramethylsilane (TMS) as an internal standard for chemical shift calibration ($\delta = 0.00$ ppm).
- Instrument Setup: Place the sample in the NMR spectrometer. Ensure the instrument is locked onto the deuterium signal of the solvent and properly shimmed to achieve a homogeneous magnetic field.
- ^1H NMR Acquisition: Acquire the spectrum using a standard single-pulse experiment. A spectral width of ~ 12 ppm, an acquisition time of ~ 3 - 4 seconds, and a relaxation delay of 2-5 seconds are typical starting points.
- ^{13}C NMR Acquisition: Acquire the spectrum using a proton-decoupled pulse program (e.g., zgpg30). A wider spectral width (~ 220 ppm) is required. Due to the lower natural abundance and smaller gyromagnetic ratio of ^{13}C , a larger number of scans (from hundreds to thousands) and a longer experiment time will be necessary to achieve a good signal-to-noise ratio.

Protocol 2: FT-IR Spectrum Acquisition (Thin Film)

- Objective: To obtain a transmission IR spectrum to identify functional groups.
- Methodology:
 - Sample Preparation: Dissolve a small amount of **tert-butylidiphenylmethanol** in a volatile solvent (e.g., dichloromethane).
 - Film Creation: Place a drop of the solution onto a salt plate (e.g., NaCl or KBr) and allow the solvent to evaporate completely, leaving a thin, uniform film of the analyte.
 - Scientist's Note: This method is fast and avoids interference from mulling agents (like Nujol) or water in KBr pellets. Ensure the film is not too thick to avoid total absorption (flat-topped peaks).
 - Background Scan: Place an empty salt plate (or the clean, empty sample holder) in the spectrometer and run a background scan. This is crucial to subtract the absorbance of CO_2 , water vapor, and the salt plate itself from the final spectrum.

- Sample Scan: Place the sample plate in the spectrometer and acquire the spectrum. Typically, 16-32 scans are co-added to improve the signal-to-noise ratio.

Integrated Spectroscopic Workflow

Confirming a structure requires the logical integration of all spectroscopic data. No single technique provides the complete picture. The workflow below illustrates how these techniques are synergistically applied for a self-validating conclusion.

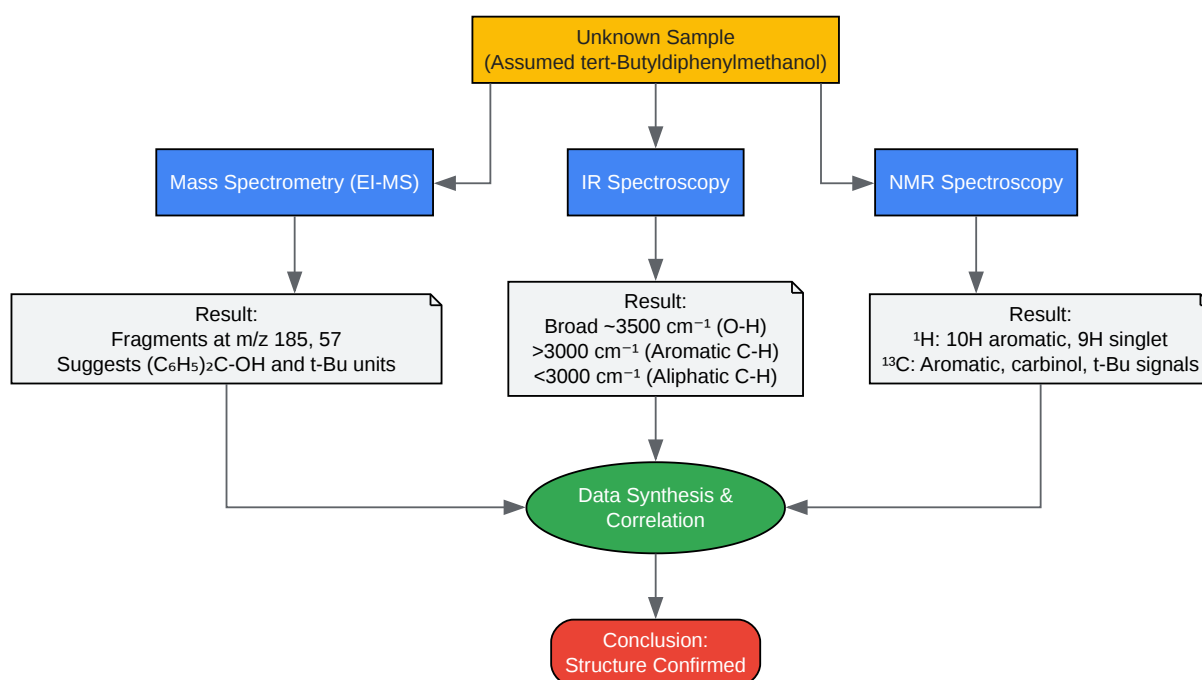

[Click to download full resolution via product page](#)

Caption: Integrated workflow for the structural confirmation of **tert-butylidiphenylmethanol**.

References

For further reading and access to spectral databases, the following resources are recommended:

- Spectral Database for Organic Compounds (SDBS), National Institute of Advanced Industrial Science and Technology (AIST), Japan. URL: [\[Link\]](#)
- Pavia, D.L., Lampman, G.M., Kriz, G.S., & Vyvyan, J.R. (2014). Introduction to Spectroscopy. Cengage Learning.
- Silverstein, R.M., Webster, F.X., Kiemle, D.J., & Bryce, D.L. (2014). Spectrometric Identification of Organic Compounds. John Wiley & Sons.
- [To cite this document: BenchChem. \[An In-Depth Technical Guide to the Spectroscopic Characterization of tert-Butyldiphenylmethanol\]. BenchChem, \[2026\]. \[Online PDF\]. Available at: \[https://www.benchchem.com/product/b156343/docs#an-in-depth-technical-guide-to-the-spectroscopic-characterization-of-tert-butyldiphenylmethanol\]](#)

Disclaimer & Data Validity:

The information provided in this document is for Research Use Only (RUO) and is strictly not intended for diagnostic or therapeutic procedures. While BenchChem strives to provide accurate protocols, we make no warranties, express or implied, regarding the fitness of this product for every specific experimental setup.

Technical Support: The protocols provided are for reference purposes. Unsure if this reagent suits your experiment?

Need Industrial/Bulk Grade? [Request Custom Synthesis Quote](#)

BenchChem

Our mission is to be the trusted global source of essential and advanced chemicals, empowering scientists and researchers to drive progress in science and industry.

Contact

Address: 3281 E Guasti Rd
Ontario, CA 91761, United States
Phone: (601) 213-4426
Email: info@benchchem.com

Contact our Ph.D. Support Team for a compatibility check