

An In-depth Technical Guide to the MAX Protein Core

Author: BenchChem Technical Support Team. **Date:** April 2026

Compound of Interest

Compound Name: MAX8
Cat. No.: B15599402

[Get Quote](#)

For Researchers, Scientists, and Drug Development Professionals

Introduction

The MYC-associated factor X (MAX) protein stands as a pivotal component in the intricate network of transcriptional regulation that governs fundamental cellular processes. As a member of the basic helix-loop-helix leucine zipper (bHLHZ) family of transcription factors, MAX functions as an obligate dimerization partner for the MYC and MAD families of proteins. This central role places MAX at the heart of cellular decision-making, influencing cell proliferation, differentiation, and apoptosis.[1][2] Dysregulation of the network in which MAX operates is a hallmark of many human cancers, making it a subject of intense research and a potential target for therapeutic intervention. This technical guide provides a comprehensive review of the literature on the MAX protein, detailing its signaling pathways, the experimental methodologies used to study it, and the quantitative data that underpins our current understanding.

The MYC/MAX/MAD Network: A Duality of Function

The functional output of MAX is determined by its dimerization partner. It can form homodimers (MAX:MAX) or, more significantly, heterodimers with members of the MYC or MAD protein

families.[1] This dynamic interplay of dimerization partners competing for a finite pool of MAX protein dictates the transcriptional outcome at shared target gene promoters.

- **MYC:MAX Heterodimers:** The oncoprotein MYC, when dimerized with MAX, acts as a potent transcriptional activator. This complex binds to specific DNA sequences known as E-boxes (5'-CACGTG-3') in the promoter regions of target genes, driving the expression of genes involved in cell cycle progression, proliferation, and metabolism.[3][4]
- **MAD:MAX Heterodimers:** In contrast, the MAD family of proteins (including MAD1, MXI1, MAD3, and MAD4) act as antagonists to MYC function.[5] When MAD proteins dimerize with MAX, the resulting complex also binds to E-box sequences but functions as a transcriptional repressor, recruiting co-repressor complexes to silence gene expression.[6][7]
- **MAX:MAX Homodimers:** MAX can also form homodimers which are capable of binding to E-boxes. While initially thought to be transcriptionally inactive or repressive, some studies suggest they may have a modest transcriptional activation potential.[8]

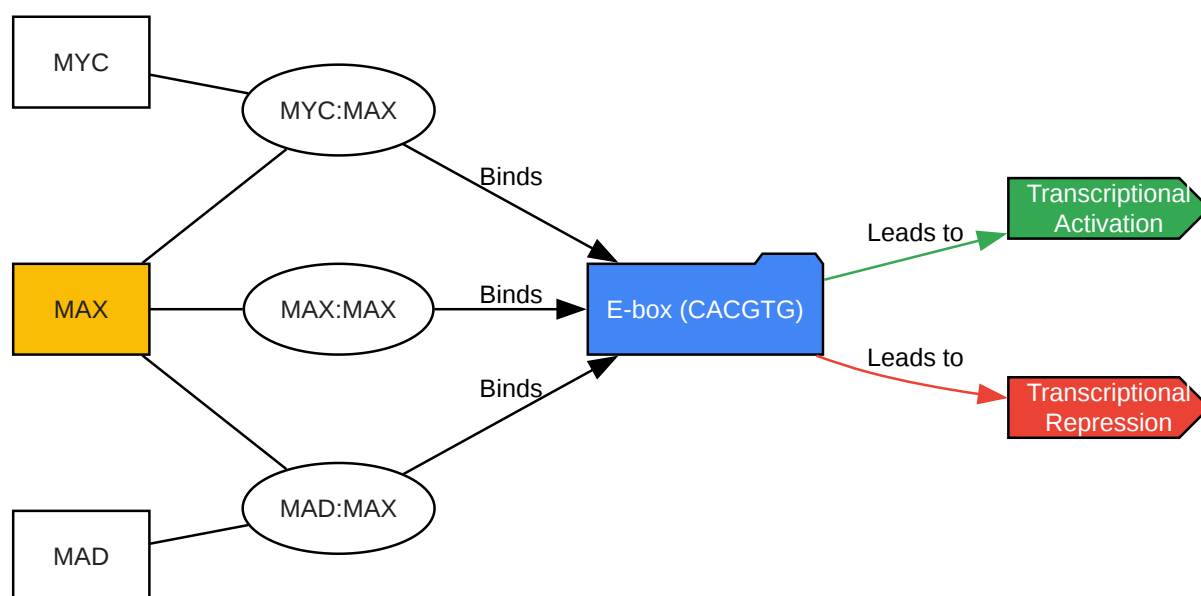

[Click to download full resolution via product page](#)

Figure 1: The MYC/MAX/MAD dimerization network and its impact on transcription.

Upstream Regulation of the Network

The balance between MYC:MAX and MAD:MAX complexes is tightly regulated by a variety of upstream signaling pathways that control the expression and stability of the individual components. The MAX gene itself is constitutively expressed in most cell types, ensuring a constant availability of the MAX protein.[9][10] This places the regulatory emphasis on the levels of MYC and MAD proteins.

- Regulation of MYC: The expression of MYC is induced by numerous mitogenic signaling pathways, including the Receptor Tyrosine Kinase (RTK)-MAPK and WNT/ β -catenin pathways.[3] MYC protein is also subject to post-translational modifications that regulate its stability.
- Regulation of MAD: In contrast, the expression of MAD family genes is often induced during cellular differentiation, leading to a switch from a proliferative (MYC-driven) to a differentiated (MAD-driven) state.[11]
- Regulation of MAX: The SWI/SNF chromatin remodeling complex, specifically the ATPase subunit BRG1, has been shown to directly regulate the expression of MAX by binding to its promoter.[10][12]

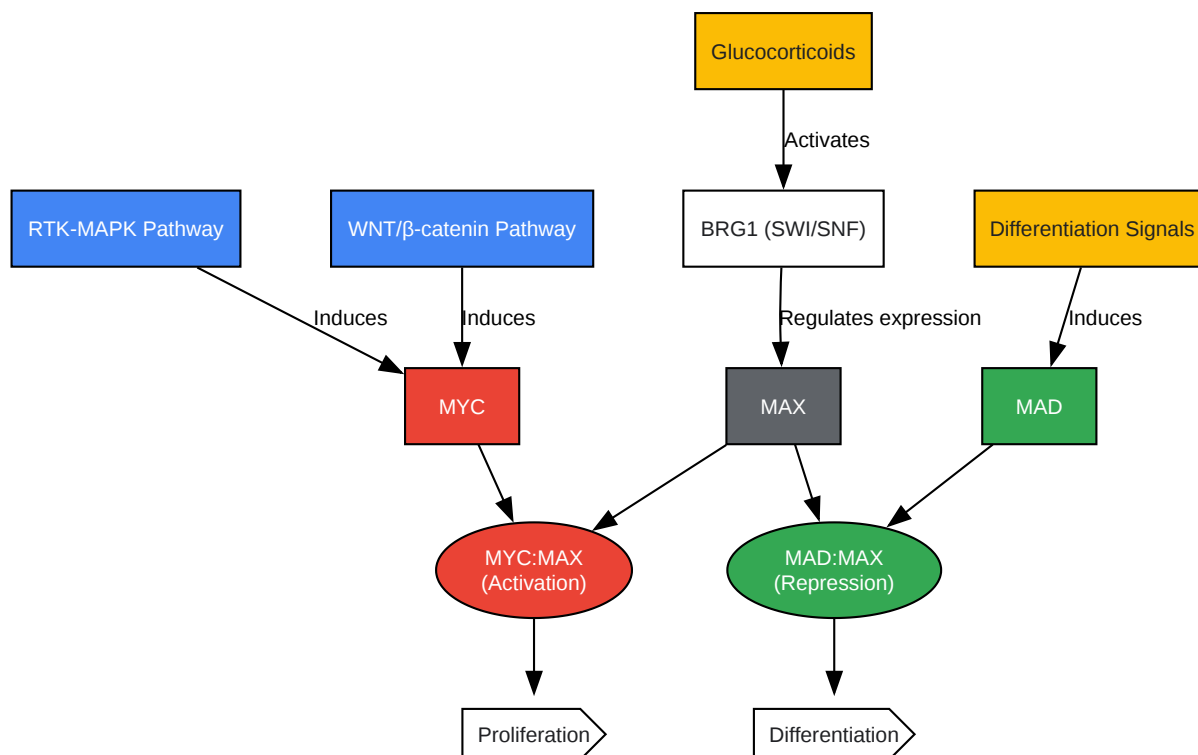

[Click to download full resolution via product page](#)

Figure 2: Upstream signaling pathways regulating the MYC/MAX/MAD network.

Downstream Effects: Gene Regulation and Metabolic Reprogramming

The transcriptional activity of the MYC/MAX/MAD network has profound effects on a wide array of cellular processes.

Transcriptional Activation and Repression

MYC:MAX heterodimers activate a broad spectrum of target genes that promote cell growth and division. Conversely, MAD:MAX heterodimers repress these same genes, often leading to cell cycle arrest and differentiation.

Target Gene	Function	Regulation by MYC:MAX	Regulation by MAD:MAX
ODC1	Ornithine decarboxylase, polyamine biosynthesis	Activation	Repression
CDK4	Cyclin-dependent kinase 4, cell cycle G1 progression	Activation	Repression
CCND2	Cyclin D2, cell cycle G1/S transition	Activation	Repression
TERT	Telomerase reverse transcriptase, telomere maintenance	Activation	Repression
p21 (CDKN1A)	Cyclin-dependent kinase inhibitor 1A, cell cycle arrest	Repression (via Miz-1)	Activation

Metabolic Rewiring in Cancer

A critical function of the MYC/MAX/MAD network is the regulation of cellular metabolism. In certain cancers, such as small cell lung cancer (SCLC), loss-of-function mutations in MAX lead to a metabolic rewiring that promotes tumor growth.[13][14] Specifically, the loss of MAX-mediated repression (likely through MAD:MAX) leads to the upregulation of genes involved in serine and one-carbon metabolism.[13][15] This provides the cancer cells with the necessary building blocks for nucleotide synthesis and redox balance, conferring a survival advantage.[7][16]

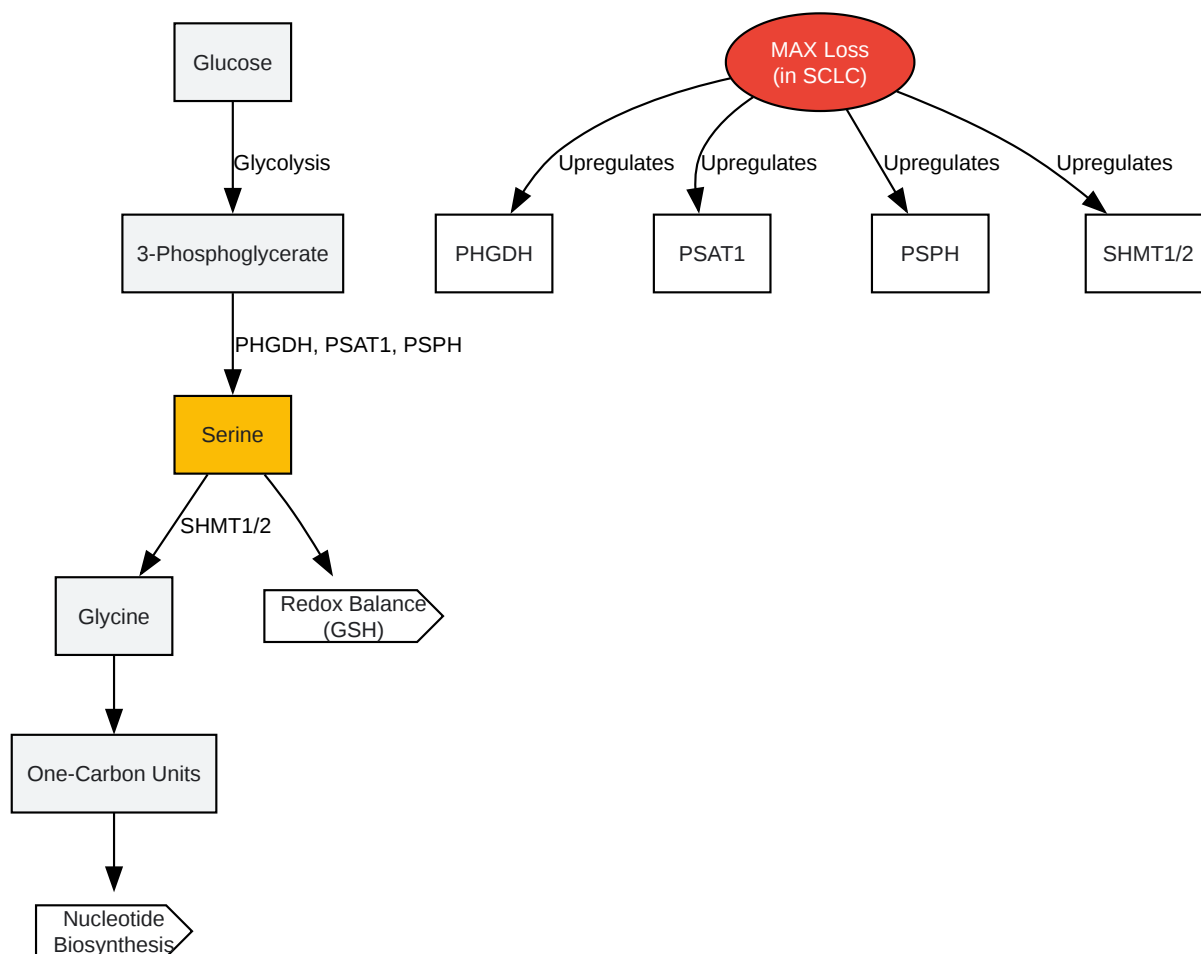

[Click to download full resolution via product page](#)

Figure 3: Upregulation of the serine biosynthesis pathway upon MAX loss in SCLC.

MAX in Disease: A Tumor Suppressor Role

While MYC is a well-established oncogene, MAX has been identified as a tumor suppressor in specific contexts.

- Hereditary Pheochromocytoma and Paraganglioma (PCC/PGL): Germline mutations in the MAX gene are a cause of hereditary PCC/PGL.[1][14][17] These mutations are typically loss-of-function, leading to the development of these neuroendocrine tumors.[1][13] Interestingly,

there appears to be a parent-of-origin effect, with a higher risk of disease when the mutation is inherited from the father.[13][17]

- Small Cell Lung Cancer (SCLC): Inactivating mutations in MAX are also found in SCLC.[10] In this context, loss of MAX disrupts the normal transcriptional programs and contributes to tumor progression through metabolic reprogramming.[13][14] The loss of MAX has been shown to create a dependency on the BRG1 subunit of the SWI/SNF complex, suggesting a potential synthetic lethal therapeutic strategy.[10][18]

MAX Mutation	Associated Phenotype	Inheritance
Germline loss-of-function	Hereditary Pheochromocytoma/Paraganglioma	Autosomal dominant with paternal parent-of-origin effect
Somatic inactivation	Small Cell Lung Cancer	Sporadic

Therapeutic Targeting of the MYC-MAX Interaction

Given the central role of the MYC:MAX heterodimer in driving many cancers, disrupting this protein-protein interaction is a major goal in drug development.[9][19]

- Small Molecule Inhibitors: Several small molecules have been developed that aim to prevent the dimerization of MYC and MAX.[2][9] These compounds are designed to bind to the bHLH-LZ domain of MYC, preventing its association with MAX and subsequent DNA binding.[2]
- Peptide-based Inhibitors: Another strategy involves the use of dominant-negative peptides, such as Omomyc, which can sequester MYC and prevent it from binding to MAX and DNA.[9][20]

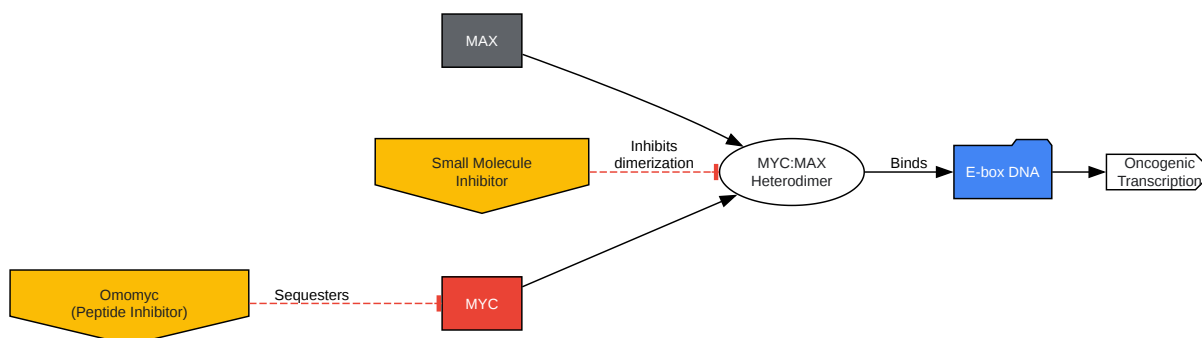

[Click to download full resolution via product page](#)

Figure 4: Therapeutic strategies targeting the MYC-MAX interaction.

Experimental Protocols

Co-immunoprecipitation (Co-IP) for MAX Protein Interactions

This protocol is designed to isolate MAX and its interacting partners from cell lysates.

- Cell Lysis:
 - Harvest cells and wash with ice-cold PBS.
 - Lyse cells in a non-denaturing lysis buffer (e.g., 50 mM Tris-HCl pH 7.4, 150 mM NaCl, 1 mM EDTA, 1% NP-40) supplemented with protease and phosphatase inhibitors.[21][22]
 - Incubate on ice and then centrifuge to pellet cell debris. Collect the supernatant containing the protein lysate.
- Immunoprecipitation:
 - Pre-clear the lysate by incubating with protein A/G beads to reduce non-specific binding.

- Incubate the pre-cleared lysate with a primary antibody specific for MAX overnight at 4°C with gentle rotation.
- Add protein A/G beads to capture the antibody-protein complexes and incubate for 1-2 hours at 4°C.
- Washing and Elution:
 - Pellet the beads by centrifugation and wash several times with lysis buffer to remove non-specifically bound proteins.
 - Elute the protein complexes from the beads by boiling in SDS-PAGE sample buffer.
- Analysis:
 - Separate the eluted proteins by SDS-PAGE and transfer to a membrane for Western blotting.
 - Probe the membrane with antibodies against suspected interacting partners (e.g., MYC, MAD1) to confirm the interaction.

Chromatin Immunoprecipitation Sequencing (ChIP-seq) for MAX Target Gene Identification

This protocol allows for the genome-wide identification of DNA regions bound by MAX.

- Cross-linking and Chromatin Preparation:
 - Cross-link protein-DNA complexes in live cells using formaldehyde.
 - Lyse the cells and isolate the nuclei.
 - Sonify the chromatin to shear the DNA into fragments of 200-500 bp.[\[23\]](#)[\[24\]](#)
- Immunoprecipitation:
 - Incubate the sheared chromatin with an antibody specific for MAX overnight at 4°C.

- Add protein A/G magnetic beads to capture the antibody-chromatin complexes.
- Washing and Elution:
 - Wash the beads extensively to remove non-specifically bound chromatin.
 - Elute the chromatin from the beads and reverse the cross-links by heating.
- DNA Purification and Sequencing:
 - Purify the immunoprecipitated DNA.
 - Prepare a sequencing library from the purified DNA and perform high-throughput sequencing.[\[25\]](#)[\[26\]](#)
- Data Analysis:
 - Align the sequencing reads to a reference genome.
 - Use peak-calling algorithms to identify regions of the genome that are enriched for MAX binding.
 - Annotate the peaks to identify the associated genes, which are potential direct targets of MAX.

Quantitative Data Summary

The following table summarizes key quantitative data related to the interactions within the MYC/MAX/MAD network.

Interacting Proteins	Method	Dissociation Constant (Kd)	Reference
MAX-MAX	Fluorescence Anisotropy	~3.7 x MYC-MAX Kd	[27]
MYC-MAX	Fluorescence Anisotropy	Most stable heterodimer	[27]
MAD-MAX	Fluorescence Anisotropy	~1.4 x MYC-MAX Kd	[27]
MYC-MAX + E-box DNA	Kinetic Analysis	$K(XYD) = (6.9 \pm 2.2) \times 10^6 \text{ M}^{-1}$	[28]
MAX-MAX + E-box DNA	Kinetic Analysis	$K(XXD) = (7.8 \pm 2.6) \times 10^6 \text{ M}^{-1}$	[28]
MAX-MAX + Curcuminoid inhibitor	In vitro expression	9 μM	[28]

Conclusion

The MAX protein is a critical nexus in the regulation of gene expression, acting as a molecular switch that, depending on its dimerization partner, can either promote or inhibit cell proliferation and growth. Its constitutive expression underscores its fundamental role in cellular homeostasis, while its dysregulation through mutations or alterations in its network partners is a key driver in several cancers. The intricate signaling pathways that converge on the MYC/MAX/MAD network, and the downstream consequences on transcription and metabolism, offer a rich field for further investigation. A deeper understanding of these processes, aided by the quantitative and methodological approaches outlined in this guide, will be crucial for the development of novel therapeutic strategies that target this pivotal protein and its associated pathways.

Need Custom Synthesis?

BenchChem offers custom synthesis for rare earth carbides and specific isotopic labeling.

Email: info@benchchem.com or [Request Quote Online](#).

References

- [1. researchgate.net \[researchgate.net\]](#)
- [2. Taking the Myc out of cancer: toward therapeutic strategies to directly inhibit c-Myc - PMC \[pmc.ncbi.nlm.nih.gov\]](#)
- [3. pubs.acs.org \[pubs.acs.org\]](#)
- [4. m.youtube.com \[m.youtube.com\]](#)
- [5. Visualization of Myc/Max/Mad Family Dimers and the Competition for Dimerization in Living Cells - PMC \[pmc.ncbi.nlm.nih.gov\]](#)
- [6. scholars.mssm.edu \[scholars.mssm.edu\]](#)
- [7. Serine Metabolic Reprogramming in Tumorigenesis, Tumor Immunity, and Clinical Treatment - PMC \[pmc.ncbi.nlm.nih.gov\]](#)
- [8. oncotarget.com \[oncotarget.com\]](#)
- [9. Strategically targeting MYC in cancer - PMC \[pmc.ncbi.nlm.nih.gov\]](#)
- [10. aacrjournals.org \[aacrjournals.org\]](#)
- [11. researchgate.net \[researchgate.net\]](#)
- [12. Proteomics strategy for quantitative protein interaction profiling in cell extracts | Springer Nature Experiments \[experiments.springernature.com\]](#)
- [13. services.myriad.com \[services.myriad.com\]](#)
- [14. MAX mutations cause hereditary and sporadic pheochromocytoma and paraganglioma - PubMed \[pubmed.ncbi.nlm.nih.gov\]](#)
- [15. Reprogramming of Serine, Glycine and One-Carbon Metabolism in Cancer - PMC \[pmc.ncbi.nlm.nih.gov\]](#)
- [16. Increased serine synthesis provides an advantage for tumors arising in tissues where serine levels are limiting - PMC \[pmc.ncbi.nlm.nih.gov\]](#)
- [17. s3-us-west-2.amazonaws.com \[s3-us-west-2.amazonaws.com\]](#)
- [18. MAX inactivation in small cell lung cancer disrupts MYC-SWI/SNF programs and is synthetic lethal with BRG1 - PubMed \[pubmed.ncbi.nlm.nih.gov\]](#)
- [19. graphyonline.com \[graphyonline.com\]](#)
- [20. Frontiers | Strategies to target the cancer driver MYC in tumor cells \[frontiersin.org\]](#)
- [21. assaygenie.com \[assaygenie.com\]](#)

- [22. Co-IP Protocol-How To Conduct A Co-IP - Creative Proteomics \[creative-proteomics.com\]](#)
- [23. Visualization of Myc/Max/Mad family dimers and the competition for dimerization in living cells - PubMed \[pubmed.ncbi.nlm.nih.gov\]](#)
- [24. Practical Guidelines for the Comprehensive Analysis of CHIP-seq Data - PMC \[pmc.ncbi.nlm.nih.gov\]](#)
- [25. A New Way to Target Cancers Using 'Synthetic Lethality' \[today.ucsd.edu\]](#)
- [26. sopachem.com \[sopachem.com\]](#)
- [27. Thermodynamics of Protein–Protein Interactions of cMyc, Max, and Mad: Effect of Polyions on Protein Dimerization - PMC \[pmc.ncbi.nlm.nih.gov\]](#)
- [28. Determination of binding constant of transcription factor myc-max/max-max and E-box DNA: the effect of inhibitors on the binding - PubMed \[pubmed.ncbi.nlm.nih.gov\]](#)
- To cite this document: BenchChem. [An In-depth Technical Guide to the MAX Protein Core]. BenchChem, [2026]. [Online PDF]. Available at: [\[https://www.benchchem.com/product/b15599402/docs#an-in-depth-technical-guide-to-the-max-protein-core\]](https://www.benchchem.com/product/b15599402/docs#an-in-depth-technical-guide-to-the-max-protein-core)

Disclaimer & Data Validity:

The information provided in this document is for Research Use Only (RUO) and is strictly not intended for diagnostic or therapeutic procedures. While BenchChem strives to provide accurate protocols, we make no warranties, express or implied, regarding the fitness of this product for every specific experimental setup.

Technical Support: The protocols provided are for reference purposes. Unsure if this reagent suits your experiment?

Need Industrial/Bulk Grade? [Request Custom Synthesis Quote](#)

BenchChem

Our mission is to be the trusted global source of essential and advanced chemicals, empowering scientists and researchers to drive progress in science and industry.

Contact

Address: 3281 E Guasti Rd

Ontario, CA 91761, United States

Phone: (601) 213-4426

Email: info@benchchem.com

[Contact our Ph.D. Support Team for a compatibility check](#)