

# diSulfo-Cy3 Alkyne: A Comprehensive Technical Guide

**Author:** BenchChem Technical Support Team. **Date:** April 2026

## Compound of Interest

Compound Name: *diSulfo-Cy3 alkyne*

Cat. No.: *B15598285*

[Get Quote](#)

For Researchers, Scientists, and Drug Development Professionals

## Introduction

**diSulfo-Cy3 alkyne** is a water-soluble, orange-fluorescent dye that plays a critical role in modern bioconjugation and cellular imaging.<sup>[1][2][3]</sup> As a member of the cyanine dye family, it exhibits bright and stable fluorescence.<sup>[4][5]</sup> Its key feature is a terminal alkyne group, which allows it to readily participate in copper(I)-catalyzed azide-alkyne cycloaddition (CuAAC) click chemistry.<sup>[3][6]</sup> This reaction enables the precise and efficient labeling of azide-modified biomolecules, such as proteins, peptides, and nucleic acids, even in complex biological samples.<sup>[7][8]</sup> The presence of two sulfonate groups imparts excellent water solubility, minimizing the need for organic co-solvents and making it highly compatible with aqueous biological systems.<sup>[4][5]</sup>

## Core Properties and Specifications

The physicochemical and spectroscopic properties of **diSulfo-Cy3 alkyne** are summarized below. These parameters are essential for designing and executing labeling experiments and for selecting appropriate instrumentation for fluorescence detection.

## Physicochemical Properties

Property	Value	Reference
Molecular Formula	C <sub>33</sub> H <sub>38</sub> N <sub>3</sub> NaO <sub>7</sub> S <sub>2</sub> / C <sub>35</sub> H <sub>43</sub> N <sub>3</sub> O <sub>10</sub> S <sub>3</sub> (free acid)	[1][9]
Molecular Weight	675.8 g/mol / 761.93 g/mol (free acid)	[1][9]
CAS Number	2055138-88-8	[1][2]
Purity	≥90-95% (HPLC)	[1][9]
Appearance	Solid, pink/dark red	[9][10]
Solubility	Water, DMSO, DMF, DCM, MeOH	[1][3][9]
Storage Conditions	-20°C, in the dark, desiccated	[1][9][11]

## Spectroscopic Properties

Property	Value	Reference
Excitation Maximum (λ <sub>abs</sub> )	548 - 555 nm	[1][3][9]
Emission Maximum (λ <sub>em</sub> )	566 - 572 nm	[3][9]
Extinction Coefficient (ε)	150,000 - 162,000 cm <sup>-1</sup> M <sup>-1</sup>	[1][3]
Fluorescence Quantum Yield (Φ)	0.15	[1]

## Mechanism of Action: Copper-Catalyzed Azide-Alkyne Cycloaddition (CuAAC)

**diSulfo-Cy3 alkyne** is primarily utilized in CuAAC, a cornerstone of click chemistry. This reaction forms a stable triazole linkage between the alkyne-functionalized dye and an azide-modified target molecule.[3][7] The reaction is highly specific, efficient, and biocompatible, proceeding readily in aqueous buffers over a wide pH range (4-11) and at room temperature.[6][12]

The copper(I) catalyst, typically generated in situ from a copper(II) salt (e.g.,  $\text{CuSO}_4$ ) and a reducing agent (e.g., sodium ascorbate), is crucial for accelerating the reaction.[12]

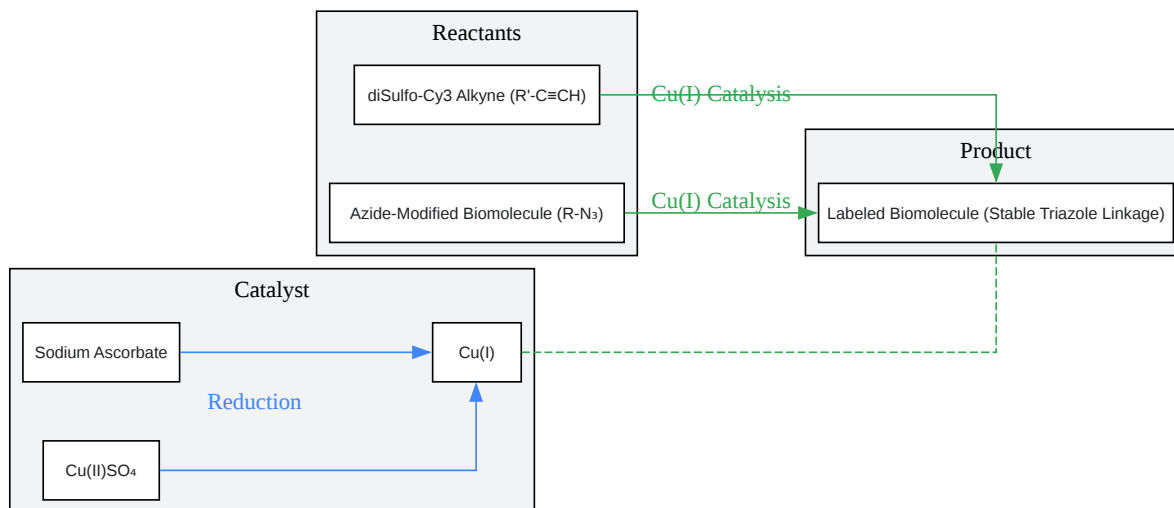

[Click to download full resolution via product page](#)

Copper-Catalyzed Azide-Alkyne Cycloaddition (CuAAC) Pathway.

## Experimental Protocols

The following protocols provide a general framework for labeling azide-modified biomolecules with **diSulfo-Cy3 alkyne**. Optimization may be required depending on the specific application and biomolecules involved.

### Labeling of Azide-Modified Proteins

This protocol is adapted from standard click chemistry procedures.

Materials:

- **diSulfo-Cy3 alkyne**
- Azide-modified protein in a suitable buffer (e.g., PBS)
- Copper(II) sulfate ( $\text{CuSO}_4$ ) stock solution (e.g., 50 mM in water)
- Sodium ascorbate stock solution (e.g., 500 mM in water, freshly prepared)
- DMSO (optional, for dissolving reagents)
- Purification column (e.g., size-exclusion chromatography)

Procedure:

- Prepare the reaction mixture in the following order:
  - Azide-modified protein (final concentration: 1-10 mg/mL)
  - **diSulfo-Cy3 alkyne** (2-5 molar excess over the protein)
  - Copper(II) sulfate (final concentration: 1-2.5 mM)
  - Sodium ascorbate (final concentration: 5-10 mM)
- Incubate the reaction mixture for 1-2 hours at room temperature, protected from light.
- Purify the labeled protein from excess dye and catalyst using a size-exclusion chromatography column appropriate for the protein's molecular weight.
- Verify labeling efficiency using SDS-PAGE with in-gel fluorescence scanning and/or UV-Vis spectroscopy.

## Labeling of Azide-Modified Oligonucleotides

This protocol is based on established methods for nucleic acid labeling.[\[13\]](#)

Materials:

- **diSulfo-Cy3 alkyne**

- Alkyne-modified oligonucleotide
- Triethylammonium acetate (TEAA) buffer (2 M, pH 7.0)
- DMSO
- Copper(II)-TBTA complex stock solution (10 mM in 55% DMSO)
- Ascorbic acid stock solution (5 mM in water, freshly prepared)
- Reagents for precipitation (e.g., lithium perchlorate in acetone or sodium acetate and ethanol)

Procedure:

- Dissolve the alkyne-modified oligonucleotide in water.
- Add TEAA buffer to a final concentration of 0.2 M.
- Add DMSO to 50% of the final volume.
- Add **diSulfo-Cy3 alkyne** (typically 1.5x molar excess over the oligonucleotide).[\[13\]](#)
- Add ascorbic acid to a final concentration of 0.5 mM.[\[13\]](#)
- Degas the solution by bubbling with an inert gas (e.g., argon) for 30 seconds.[\[13\]](#)
- Add the Copper(II)-TBTA complex to a final concentration of 0.5 mM.[\[13\]](#)
- Incubate at room temperature overnight, protected from light.
- Precipitate the labeled oligonucleotide to remove unreacted dye. For example, add a 4-fold excess volume of 3% lithium perchlorate in acetone, centrifuge, wash the pellet with acetone, and dry.[\[13\]](#)
- Purify the conjugate by RP-HPLC or PAGE.

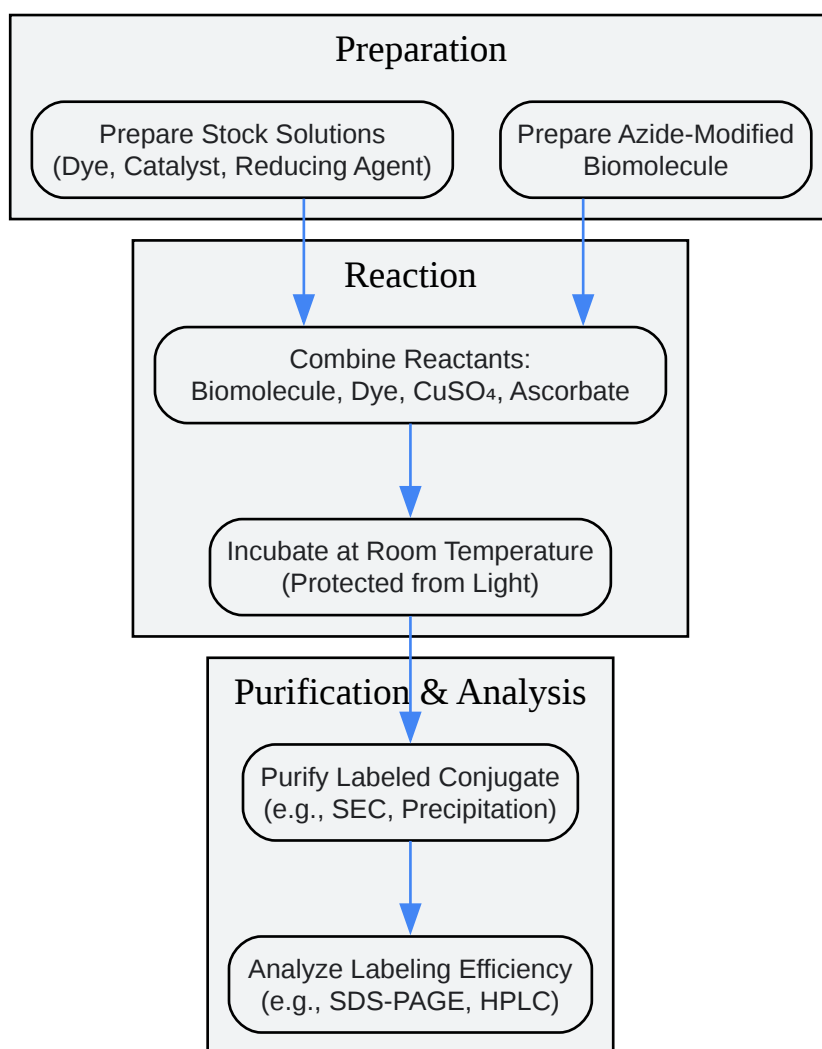

[Click to download full resolution via product page](#)

General Experimental Workflow for Biomolecule Labeling.

## Applications in Research and Drug Development

The versatility and reliability of **diSulfo-Cy3 alkyne** make it a valuable tool in numerous applications:

- **Fluorescence Imaging:** Its bright and photostable signal is ideal for visualizing labeled biomolecules in fixed and living cells using techniques like immunocytochemistry and fluorescence microscopy.<sup>[4][8]</sup>

- Protein and Peptide Labeling: Enables the tracking and quantification of proteins and peptides in various biological assays.[1][8]
- Nucleic Acid Labeling: Facilitates the detection of DNA and RNA in applications such as fluorescence in situ hybridization (FISH) and microarray analysis.[8]
- Drug Delivery and Therapeutics: The dye can be conjugated to drug delivery systems to monitor their biodistribution and cellular uptake in real-time.[4]
- Biosensing and Diagnostics: Used in the development of fluorescent biosensors and diagnostic assays for the detection of specific biomarkers.[4]

## Conclusion

**diSulfo-Cy3 alkyne** is a high-performance fluorescent probe that combines the excellent spectral properties of the Cy3 fluorophore with the versatility of click chemistry. Its high water solubility, bright fluorescence, and specific reactivity make it an indispensable tool for researchers and scientists in molecular biology, cell biology, and drug development. The robust and straightforward labeling protocols enable the covalent attachment of a bright, stable fluorophore to a wide range of biomolecules, facilitating advanced imaging and detection applications.

### *Need Custom Synthesis?*

*BenchChem offers custom synthesis for rare earth carbides and specific isotopic labeling.*

*Email: [info@benchchem.com](mailto:info@benchchem.com) or [Request Quote Online](#).*

## References

- [1. diSulfo-Cy3 alkyne, 2055138-88-8 | BroadPharm \[broadpharm.com\]](#)
- [2. medchemexpress.com \[medchemexpress.com\]](#)
- [3. Sulfo Cy3 Alkyne | AxisPharm \[axispharm.com\]](#)
- [4. alfa-chemistry.com \[alfa-chemistry.com\]](#)
- [5. lumiprobe.com \[lumiprobe.com\]](#)

- [6. interchim.fr \[interchim.fr\]](#)
- [7. interchim.fr \[interchim.fr\]](#)
- [8. Sulfo-Cyanine3 Alkyne | CAS:2055138-88-8 | AxisPharm \[axispharm.com\]](#)
- [9. Sulfo-Cy3-Alkyne, Alkyne-containing Fluorescent Dyes - Jena Bioscience \[jenabioscience.com\]](#)
- [10. interchim.fr \[interchim.fr\]](#)
- [11. lumiprobe.com \[lumiprobe.com\]](#)
- [12. Click Chemistry \[organic-chemistry.org\]](#)
- [13. lumiprobe.com \[lumiprobe.com\]](#)
- [To cite this document: BenchChem. \[diSulfo-Cy3 Alkyne: A Comprehensive Technical Guide\]. BenchChem, \[2026\]. \[Online PDF\]. Available at: \[https://www.benchchem.com/product/b15598285/docs#disulfo-cy3-alkyne-a-comprehensive-technical-guide\]](#)

---

#### Disclaimer & Data Validity:

The information provided in this document is for Research Use Only (RUO) and is strictly not intended for diagnostic or therapeutic procedures. While BenchChem strives to provide accurate protocols, we make no warranties, express or implied, regarding the fitness of this product for every specific experimental setup.

**Technical Support:** The protocols provided are for reference purposes. Unsure if this reagent suits your experiment?

**Need Industrial/Bulk Grade?** [Request Custom Synthesis Quote](#)

## BenchChem

Our mission is to be the trusted global source of essential and advanced chemicals, empowering scientists and researchers to drive progress in science and industry.

#### Contact

Address: 3281 E Guasti Rd

Ontario, CA 91761, United States

Phone: (601) 213-4426

Email: [info@benchchem.com](mailto:info@benchchem.com)

Contact our Ph.D. Support Team for a compatibility check