

Verifying Covalent Bond Formation with DiSulfo-Cy5 Alkyne: A Comparative Guide

Author: BenchChem Technical Support Team. **Date:** April 2026

Compound of Interest

Compound Name: DiSulfo-Cy5 alkyne TEA

Cat. No.: B15598582

[Get Quote](#)

For researchers, scientists, and drug development professionals, the precise and verifiable covalent labeling of biomolecules is paramount. The copper(I)-catalyzed azide-alkyne cycloaddition (CuAAC), a cornerstone of "click chemistry," offers a robust method for this purpose. **DiSulfo-Cy5 Alkyne TEA** is a fluorescent probe designed for this reaction, enabling the attachment of a bright, far-red fluorophore to azide-modified targets such as proteins, nucleic acids, and other biomolecules.^{[1][2]} Its two sulfonate groups enhance water solubility, which is crucial for biological applications.^[1]

This guide provides an objective comparison of DiSulfo-Cy5 Alkyne with alternative fluorescent alkyne dyes and details the experimental methods required to confidently verify successful covalent bond formation.

Comparison of Alkyne-Functionalized Fluorophores

The choice of a fluorescent dye depends on the specific experimental requirements, including the available excitation sources, desired emission wavelength, and the chemical environment of the reaction. While DiSulfo-Cy5 offers excellent brightness and solubility, several alternatives provide a range of spectral and chemical properties.

Property	DiSulfo-Cy5 Alkyne	AZDye 647 Alkyne (Alexa Fluor 647 analog)	DyLight 650 Alkyne	Sulfo-Cy3 Alkyne	5-TAMRA Alkyne
Excitation Max (nm)	~646	~648	~652	~555	~541-556
Emission Max (nm)	~662	~671	~672	~572	~563-575
Molar Extinction Coefficient (ϵ , $M^{-1}cm^{-1}$)	271,000	270,000	250,000	150,000	~84,000
Fluorescence Quantum Yield (Φ)	0.28	Not specified	Not specified	Not specified	0.1
Solubility	High (Water, DMSO, DMF) [1]	Water, DMSO, DMF[3]	Not specified	Water, DMSO, DMF[4]	DMSO, DMF[5]
Key Features	Highly water-soluble due to two sulfonate groups; bright far-red fluorescence. [1]	Spectrally almost identical to Cy5 and Alexa Fluor 647; photostable. [3][6]	Bright, far-red dye; spectrally similar to Cy5 and Alexa Fluor 647. [7]	Bright orange fluorescence; less background than TAMRA. [4]	Common FRET pair with fluorescein; lower quantum yield. [8][9]

Note: Spectral properties can vary slightly depending on the solvent and conjugation state. Data is compiled from multiple sources. [1][3][4][5][6][7][8]

Verifying Covalent Conjugation

Confirmation of a stable, covalent bond between the dye and the target biomolecule is a critical step. Several methods can be employed, each providing a different level of evidence.

Gel Electrophoresis (SDS-PAGE)

Sodium Dodecyl Sulfate-Polyacrylamide Gel Electrophoresis (SDS-PAGE) is one of the most common methods to verify protein labeling. The successful conjugation of a dye to a protein results in an increase in its molecular weight, which can be observed as a shift in the protein's migration on the gel. More importantly, the protein band itself will be fluorescent.

Advantages:

- Directly visualizes that the fluorescence is associated with the target protein band.
- Allows for an estimation of labeling efficiency by comparing the fluorescent signal to a total protein stain (e.g., Coomassie Blue).
- Relatively simple and widely accessible technique.

Disadvantages:

- Small molecular weight shifts may be difficult to resolve.
- Does not confirm the exact site of labeling.

Mass Spectrometry (MS)

Mass spectrometry provides definitive evidence of covalent bond formation by measuring the precise mass of the modified biomolecule. An increase in mass corresponding to the exact molecular weight of the alkyne dye confirms a successful reaction.^[10]

Advantages:

- Unambiguously confirms the mass of the conjugate, providing direct proof of covalent labeling.^[10]
- Can be used to determine the stoichiometry of labeling (i.e., the number of dye molecules per protein).^[10]

- Tandem MS (MS/MS) techniques can identify the specific amino acid residue(s) where the dye has been attached.

Disadvantages:

- Requires specialized equipment and expertise.
- Can be challenging for large, complex, or hydrophobic proteins.[\[10\]](#)

High-Performance Liquid Chromatography (HPLC)

HPLC separates molecules based on properties like size, charge, or hydrophobicity. A successful conjugation reaction will result in a new peak in the chromatogram with a different retention time compared to the unlabeled biomolecule and the free dye. The new peak should exhibit both the absorbance profile of the protein and the dye.

Advantages:

- Provides quantitative data on the purity of the conjugate.
- Can be used to separate the labeled product from unreacted starting materials.
- High sensitivity and resolution.

Disadvantages:

- Requires method development to achieve optimal separation.
- Does not provide information on the location of the label.

Experimental Protocols

Protocol 1: Labeling an Azide-Modified Protein with DiSulfo-Cy5 Alkyne

This protocol outlines a general procedure for the copper-catalyzed click reaction (CuAAC) to label a protein containing an azide group.

Materials:

- Azide-modified protein in a copper-free buffer (e.g., PBS, HEPES).
- **DiSulfo-Cy5 Alkyne TEA** (or alternative alkyne dye).
- Click Reaction Buffer Components:
 - Copper (II) Sulfate (CuSO_4) stock solution (e.g., 20 mM in water).
 - Copper-chelating ligand, e.g., THPTA (100 mM in water).
 - Reducing agent, e.g., Sodium Ascorbate (300 mM in water, freshly prepared).
- DMSO for dissolving the dye.
- Purification column (e.g., desalting spin column) to remove excess dye.

Procedure:

- Prepare Reagents:
 - Dissolve DiSulfo-Cy5 Alkyne in DMSO to create a 10 mM stock solution.
 - Prepare fresh Sodium Ascorbate solution.
- Prepare Protein:
 - To a microcentrifuge tube, add your azide-modified protein to a final concentration of 1-5 mg/mL.
- Set up the Reaction: For a 100 μL final reaction volume:
 - Add 50 μL of the protein solution.
 - Add 2 μL of the 10 mM DiSulfo-Cy5 Alkyne stock (final concentration: 200 μM).
 - Add 10 μL of the 100 mM THPTA solution.
 - Add 10 μL of the 20 mM CuSO_4 solution and vortex briefly.

- To initiate the reaction, add 10 μ L of the 300 mM Sodium Ascorbate solution. Vortex briefly.
- Incubation:
 - Protect the reaction from light and incubate at room temperature for 30-60 minutes.
- Purification:
 - Remove unreacted dye and catalyst components using a desalting spin column appropriate for the molecular weight of your protein, following the manufacturer's instructions.

Protocol 2: Verification of Labeling by Fluorescent SDS-PAGE

Procedure:

- Sample Preparation:
 - Mix a small aliquot (e.g., 5-10 μ g) of your purified, labeled protein with SDS-PAGE loading buffer containing a reducing agent (like DTT or β -mercaptoethanol).
 - Include controls: an unlabeled version of your protein and a lane with pre-stained molecular weight markers.
 - Heat the samples at 95°C for 5 minutes to denature the proteins.
- Electrophoresis:
 - Load the samples onto a polyacrylamide gel.
 - Run the gel according to standard procedures until the dye front reaches the bottom.
- Visualization:
 - Carefully remove the gel from the cassette. Do not proceed to Coomassie or silver staining yet.

- Place the gel on a fluorescence gel imager equipped with filters appropriate for Cy5 (e.g., ~635 nm excitation, ~670 nm emission).
- Capture the fluorescent image. A fluorescent band should appear at the molecular weight of your target protein.
- (Optional) Total Protein Staining:
 - After fluorescence imaging, the same gel can be stained with a total protein stain like Coomassie Blue to visualize all protein bands, including the unlabeled control and molecular weight markers.
 - Compare the fluorescent image with the total protein stain to confirm the signal corresponds to your protein of interest and to assess labeling efficiency.[\[11\]](#)

Visualizations

The following diagrams illustrate the chemical reaction and a typical experimental workflow.

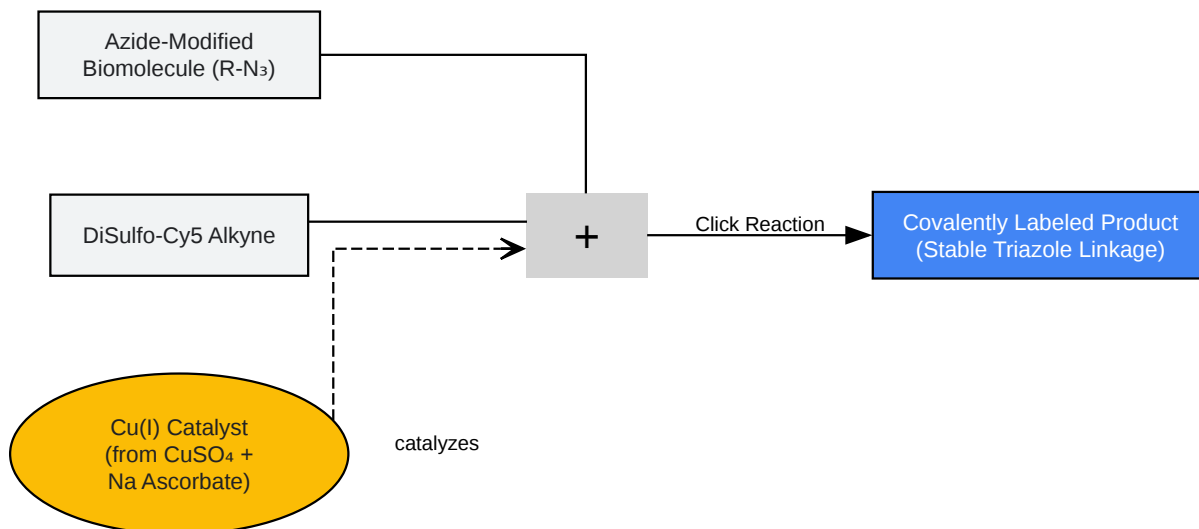

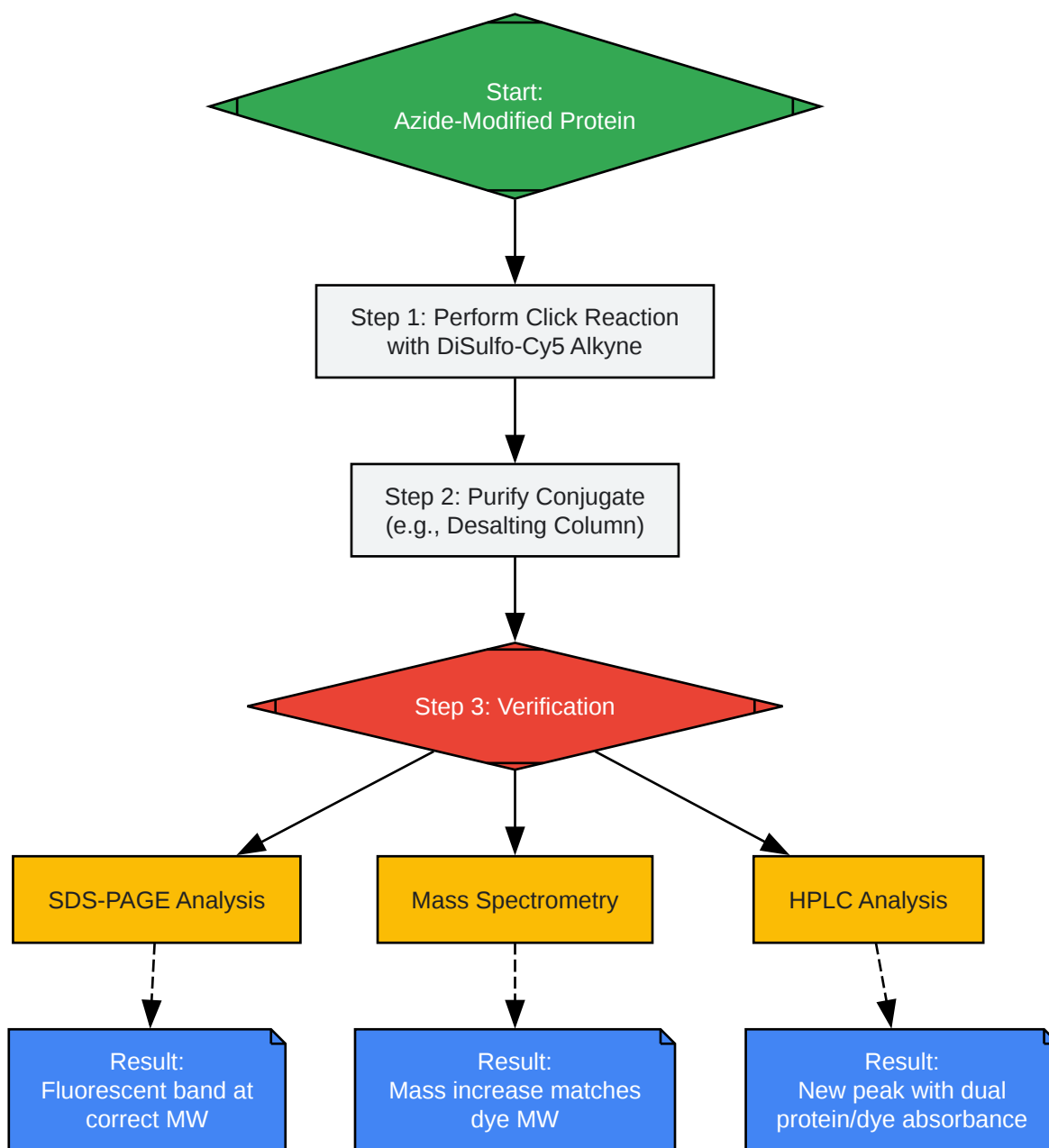

[Click to download full resolution via product page](#)

Need Custom Synthesis?

BenchChem offers custom synthesis for rare earth carbides and specific isotopic labeling.

Email: info@benchchem.com or [Request Quote Online](#).

References

- 1. 5-TAMRA-Alkyne, Alkyne-containing Fluorescent Dyes - Jena Bioscience [[jenabioscience.com](https://www.jenabioscience.com)]
- 2. documents.thermofisher.com [documents.thermofisher.com]
- 3. vectorlabs.com [vectorlabs.com]
- 4. Sulfo Cy3 Alkyne | AxisPharm [axispharm.com]
- 5. abpbio.com [abpbio.com]
- 6. AZDye647-Alkyne, Alkyne-containing Fluorescent Dyes - Jena Bioscience [[jenabioscience.com](https://www.jenabioscience.com)]
- 7. FluoroFinder [app.fluorofinder.com]
- 8. lumiprobe.com [lumiprobe.com]
- 9. TAMRA Dye - ADC Linkers | AxisPharm [axispharm.com]
- 10. Click chemistry reagent for identification of sites of covalent ligand incorporation in integral membrane proteins - PMC [pubmed.ncbi.nlm.nih.gov]
- 11. Fluorescent labeling of proteins and its application to SDS-PAGE and western blotting - PubMed [pubmed.ncbi.nlm.nih.gov]
- To cite this document: BenchChem. [Verifying Covalent Bond Formation with DiSulfo-Cy5 Alkyne: A Comparative Guide]. BenchChem, [2026]. [Online PDF]. Available at: [<https://www.benchchem.com/product/b15598582/docs#verifying-covalent-bond-formation-with-disulfo-cy5-alkyne-a-comparative-guide>]

Disclaimer & Data Validity:

The information provided in this document is for Research Use Only (RUO) and is strictly not intended for diagnostic or therapeutic procedures. While BenchChem strives to provide accurate protocols, we make no warranties, express or implied, regarding the fitness of this product for every specific experimental setup.

Technical Support: The protocols provided are for reference purposes. Unsure if this reagent suits your experiment?

Need Industrial/Bulk Grade? [Request Custom Synthesis Quote](#)

BenchChem

Our mission is to be the trusted global source of essential and advanced chemicals, empowering scientists and researchers to drive progress in science and industry.

Contact

Address: 3281 E Guasti Rd

Ontario, CA 91761, United States

Phone: (601) 213-4426

Email: info@benchchem.com

[Contact our Ph.D. Support Team for a compatibility check](#)