

Validation of a new Factor Xa assay using a chromogenic substrate

Author: BenchChem Technical Support Team. **Date:** April 2026

Compound of Interest

Compound Name: *Tos-Gly-Pro-Arg-ANBA-IPA
acetate*

Cat. No.: *B15598042*

[Get Quote](#)

A Comparative Guide to a New Chromogenic Factor Xa Assay

For Researchers, Scientists, and Drug Development Professionals

This guide provides an objective comparison of the performance of a new chromogenic Factor Xa (FXa) assay against an established alternative, supported by experimental data. Detailed methodologies for key validation experiments are included to enable a comprehensive evaluation for your laboratory's needs.

Principle of the Chromogenic Factor Xa Assay

The chromogenic Factor Xa assay is a functional test that measures the activity of Factor Xa. The core principle involves a synthetic peptide substrate that mimics the natural target of Factor Xa and is conjugated to a chromophore, typically para-nitroaniline (pNA). When Factor Xa cleaves this substrate, the pNA is released, producing a yellow color. The rate of color change, measured spectrophotometrically at 405 nm, is directly proportional to the Factor Xa activity in the sample.^{[1][2][3]}

Performance Comparison

This section compares the performance of a new, validated chromogenic FXa assay with an established chromogenic assay method. The data presented is synthesized from published validation studies to provide a representative comparison.

Table 1: Performance Characteristics of the New Chromogenic FXa Assay

Parameter	Result
Linearity (Correlation Coefficient, r^2)	0.9987
Range	0.054–0.192 IU/mL
Precision (RSD)	< 2.0%
Accuracy (Recovery)	98.0% to 102.0%
Limit of Detection (LOD)	0.011 IU/mL
Limit of Quantitation (LOQ)	0.037 IU/mL

Data synthesized from a validation study of a new anti-Xa factor potency assay.[\[1\]](#)[\[4\]](#)

Table 2: Comparison with an Established Chromogenic FXa Assay

Parameter	New Chromogenic FXa Assay	Established Chromogenic FXa Assay (BIOPHEN™ DiXal)
Linearity (Correlation Coefficient, r^2)	0.9987	0.95
Precision (Repeatability CV)	< 2.0%	< 8.0%
Precision (Reproducibility CV)	< 2.0%	< 10.0%
Limit of Quantitation	0.037 IU/mL	30 ng/mL (for Rivaroxaban)

Performance data for the established assay is based on the BIOPHEN™ DiXal kit and a comparative study.[\[3\]](#)[\[5\]](#)

Experimental Protocols

Detailed methodologies for the validation of the new chromogenic Factor Xa assay are provided below.

General Chromogenic Factor Xa Assay Protocol

This protocol outlines the fundamental steps for measuring Factor Xa activity.

- **Sample Preparation:** Prepare human citrated plasma samples. For validation purposes, samples may be spiked with known concentrations of Factor Xa or a specific inhibitor.
- **Reagent Preparation:** Reconstitute lyophilized Factor Xa, antithrombin (if applicable for anti-Xa activity), and the chromogenic substrate according to the manufacturer's instructions. A common substrate is S-2765.[2]
- **Reaction Initiation:** In a 96-well microplate, add the plasma sample to a reaction buffer.
- **Incubation with FXa:** Add a known excess amount of Factor Xa to the wells and incubate for a specific time at 37°C.
- **Chromogenic Substrate Addition:** Add the chromogenic substrate to initiate the color development reaction.
- **Absorbance Measurement:** Measure the absorbance at 405 nm using a microplate reader. The reading can be kinetic (measuring the rate of change) or endpoint (stopping the reaction with an acid and measuring the final absorbance).
- **Calculation:** Determine the Factor Xa activity by comparing the sample's absorbance to a standard curve generated with known concentrations of Factor Xa.

Validation Experiment Protocols

a) Linearity Assessment

- Prepare a series of at least five dilutions of a Factor Xa standard to cover the expected working range of the assay.

- Run each dilution in the chromogenic Factor Xa assay as described above.
- Plot the absorbance values against the known concentrations of Factor Xa.
- Perform a linear regression analysis and determine the correlation coefficient (r^2). An r^2 value close to 1.0 indicates a high degree of linearity.[1]

b) Precision (Repeatability and Reproducibility)

- Repeatability (Intra-assay precision):
 - Prepare low, medium, and high concentration samples of Factor Xa.
 - Analyze each sample multiple times (e.g., $n=10$) within the same assay run.
 - Calculate the mean, standard deviation, and coefficient of variation (CV%) for each concentration.
- Reproducibility (Inter-assay precision):
 - Analyze the same low, medium, and high concentration samples on different days, with different operators, and/or with different batches of reagents.
 - Calculate the overall mean, standard deviation, and CV% for each concentration across all runs. A lower CV% indicates higher precision.[1]

c) Accuracy (Recovery)

- Prepare a plasma sample with a known baseline Factor Xa activity.
- Spike the sample with known concentrations of a Factor Xa standard at low, medium, and high levels.
- Measure the Factor Xa activity in both the spiked and non-spiked samples.
- Calculate the percentage recovery using the following formula: $(\text{Measured Concentration in Spiked Sample} - \text{Measured Concentration in Non-spiked Sample}) / \text{Spiked Concentration} * 100\%$

- Recovery values close to 100% indicate high accuracy.[1]

Visualizing the Coagulation Cascade and Assay Workflow

To better understand the context and procedure of the Factor Xa assay, the following diagrams illustrate the coagulation pathway and the experimental workflow.

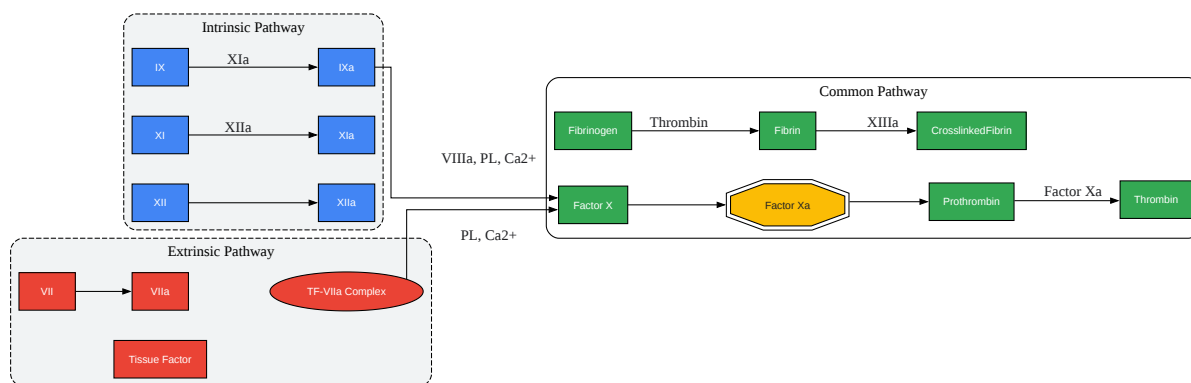

[Click to download full resolution via product page](#)

Coagulation Cascade Highlighting Factor Xa's Central Role

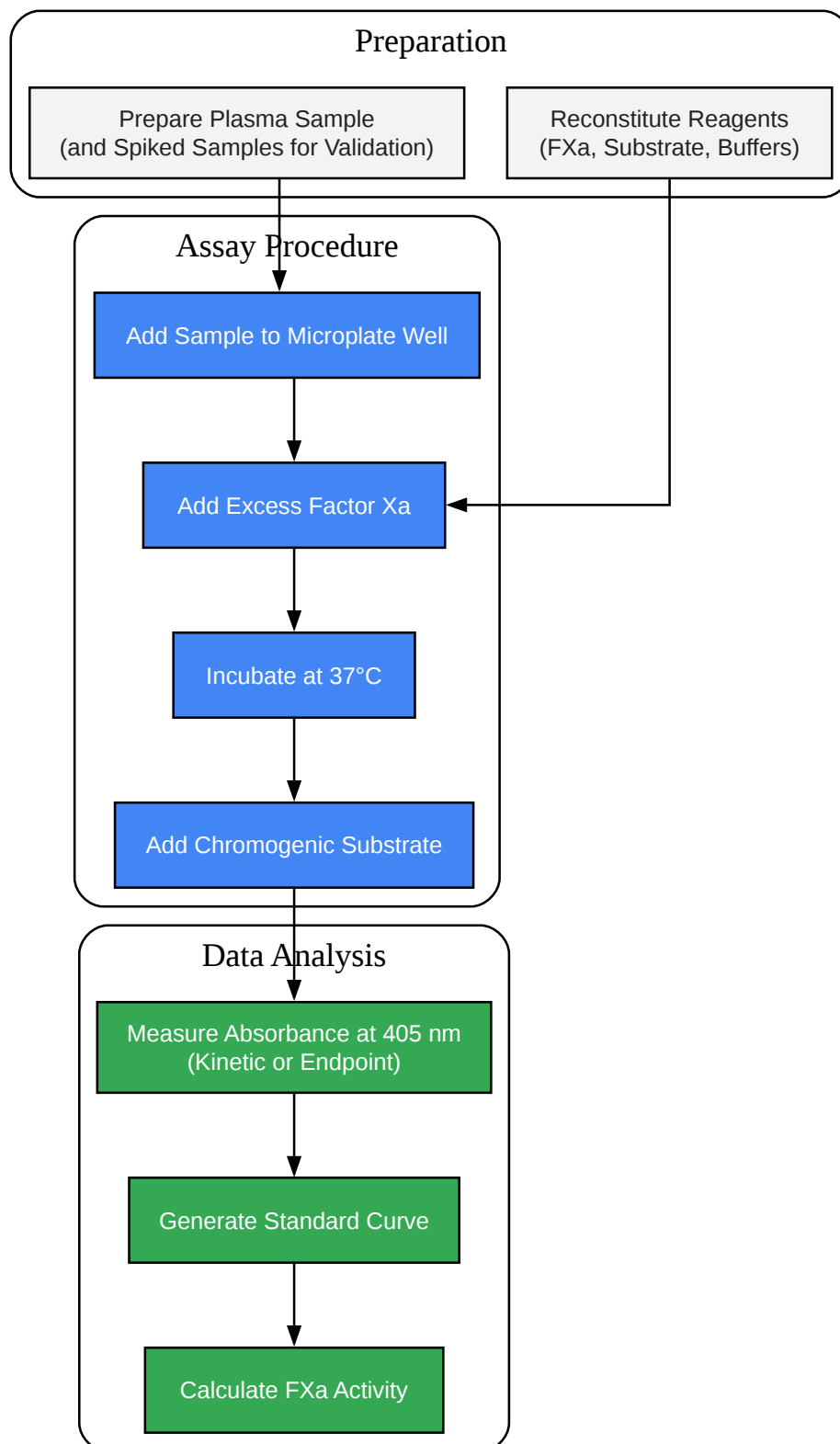

[Click to download full resolution via product page](#)

Experimental Workflow for a Chromogenic Factor Xa Assay

Need Custom Synthesis?

BenchChem offers custom synthesis for rare earth carbides and specific isotopic labeling.

Email: info@benchchem.com or [Request Quote Online](#).

References

- [1. Establishment and validation of a method for determining anti-Xa factor potency of enoxaparin sodium - PMC \[pmc.ncbi.nlm.nih.gov\]](#)
- [2. researchgate.net \[researchgate.net\]](#)
- [3. coachrom.com \[coachrom.com\]](#)
- [4. academic.oup.com \[academic.oup.com\]](#)
- [5. Comparison of calibrated chromogenic anti-Xa assay and PT tests with LC-MS/MS for the therapeutic monitoring of patients treated with rivaroxaban - PubMed \[pubmed.ncbi.nlm.nih.gov\]](#)
- To cite this document: BenchChem. [Validation of a new Factor Xa assay using a chromogenic substrate]. BenchChem, [2026]. [Online PDF]. Available at: [<https://www.benchchem.com/product/b15598042/docs#validation-of-a-new-factor-xa-assay-using-a-chromogenic-substrate>]

Disclaimer & Data Validity:

The information provided in this document is for Research Use Only (RUO) and is strictly not intended for diagnostic or therapeutic procedures. While BenchChem strives to provide accurate protocols, we make no warranties, express or implied, regarding the fitness of this product for every specific experimental setup.

Technical Support: The protocols provided are for reference purposes. Unsure if this reagent suits your experiment?

Need Industrial/Bulk Grade? [Request Custom Synthesis Quote](#)

BenchChem

Our mission is to be the trusted global source of essential and advanced chemicals, empowering scientists and researchers to drive progress in science and industry.

Contact

Address: 3281 E Guasti Rd

Ontario, CA 91761, United States

Phone: (601) 213-4426

Email: info@benchchem.com

[Contact our Ph.D. Support Team for a compatibility check](#)