

Application Notes and Protocols for Studying GroES Mobile Loop Dynamics in Solution

Author: BenchChem Technical Support Team. **Date:** April 2026

Compound of Interest

Compound Name: GroES mobile loop

Cat. No.: B15598232

[Get Quote](#)

Audience: Researchers, scientists, and drug development professionals.

Introduction: The chaperonin GroES, in conjunction with GroEL, plays a crucial role in assisting protein folding. A key structural element of GroES is its "mobile loop," a segment of approximately 16-20 amino acids that is intrinsically disordered in the free heptamer but adopts a defined β -hairpin conformation upon binding to GroEL. This dynamic transition is fundamental to the chaperonin mechanism, involving the capture and release of substrate proteins. Understanding the dynamics of this mobile loop in solution is therefore critical for elucidating the mechanism of action of the GroEL/GroES system and for the development of potential therapeutic modulators.

This document provides detailed application notes and protocols for three powerful biophysical techniques to study the dynamics of the **GroES mobile loop** in solution: Nuclear Magnetic Resonance (NMR) Spectroscopy, Fluorescence Resonance Energy Transfer (FRET), and Hydrogen-Deuterium Exchange Mass Spectrometry (HDX-MS).

Nuclear Magnetic Resonance (NMR) Spectroscopy

NMR spectroscopy is a versatile and powerful technique for characterizing protein structure and dynamics at atomic resolution. For the **GroES mobile loop**, NMR can provide information

on its conformational states, flexibility, and interactions with GroEL.

Application Note: Transferred Nuclear Overhauser Effect (trNOE) for Bound Conformation

The mobile loop of GroES is highly flexible in its free state, leading to averaged NMR signals that do not represent a single conformation. However, when bound to the large GroEL complex, the loop's tumbling rate is effectively that of the entire ~800 kDa complex. This allows for the use of transferred Nuclear Overhauser Effect (trNOE) experiments to determine the conformation of the **GroES mobile loop** when it is bound to GroEL.[1] In this technique, NOEs, which are distance-dependent effects between protons, are generated in the bound state and transferred to the free state via chemical exchange, allowing their detection. This has been instrumental in demonstrating that the mobile loop adopts a β -hairpin structure upon binding.[1]

Application Note: NMR Relaxation for Quantifying Flexibility

NMR spin relaxation experiments can provide quantitative information about the dynamics of the protein backbone on a residue-by-residue basis. By measuring relaxation rates (R_1 , R_2) and the heteronuclear NOE, one can calculate the squared generalized order parameter (S^2). The S^2 value is a measure of the spatial restriction of the N-H bond vector, with a value of 1 indicating a completely rigid bond and a value of 0 indicating unrestricted motion. For the **GroES mobile loop**, a significant change in S^2 values is expected upon binding to GroEL, reflecting the transition from a disordered to a structured state.

Quantitative Data Summary

Table 1: Representative Transferred NOE-Derived Distance Restraints for the **GroES Mobile Loop** Peptide Bound to GroEL.

Data would be derived from the analysis of trNOESY spectra and are represented here as typical examples. The actual restraints are available in the Protein Data Bank (PDB) deposition for entry 1EGS.

Residue Pair	NOE Type	Distance Restraint (Å)
Ile22 (H α) - Val26 (H α)	Intra-residue	< 3.5
Gly23 (H α) - Thr24 (H β)	Sequential	< 4.0
Val21 (H γ) - Ala27 (H β)	Long-range	< 5.0
Lys20 (H δ) - Gly28 (H α)	Long-range	< 5.5

Table 2: Representative NMR Relaxation Parameters (S^2 Order Parameter) for **GroES Mobile Loop** Residues.

These are hypothetical values to illustrate the expected trend. Actual values would be obtained from ^{15}N relaxation experiments.

Residue	S^2 (Free GroES)	S^2 (GroEL-bound GroES)	Interpretation
Gly18	0.45	0.85	Increased rigidity upon binding
Ala19	0.42	0.88	Increased rigidity upon binding
Lys20	0.38	0.90	Increased rigidity upon binding
Val21	0.40	0.91	Increased rigidity upon binding
Ile22	0.35	0.92	Increased rigidity upon binding
Gly23	0.30	0.89	Increased rigidity upon binding
Thr24	0.41	0.87	Increased rigidity upon binding

Experimental Protocol: Transferred NOE Spectroscopy

- Sample Preparation:
 - Prepare a sample of uniformly ^{15}N -labeled GroES at a concentration of 0.5-1.0 mM in a suitable NMR buffer (e.g., 20 mM phosphate, 50 mM NaCl, pH 7.0) in 90% H_2O /10% D_2O .
 - Prepare a sample of unlabeled GroEL at a concentration that gives a molar ratio of GroES:GroEL of approximately 20:1. The high excess of GroES ensures that the observed signals are predominantly from the free/exchanging species.
- NMR Data Acquisition:
 - Acquire a series of 2D ^1H - ^1H NOESY or ^{15}N -edited NOESY-HSQC spectra on a high-field NMR spectrometer (≥ 600 MHz) equipped with a cryoprobe.
 - Use a range of mixing times (e.g., 50, 100, 150, 200 ms) to monitor the build-up of NOE cross-peaks.
 - The observation of negative cross-peaks is indicative of transferred NOEs from the high molecular weight complex.
- Data Analysis:
 - Process the spectra using appropriate software (e.g., NMRPipe, Sparky).
 - Assign the resonances of the **GroES mobile loop** in the free state using standard triple-resonance experiments if necessary.
 - Integrate the volumes of the trNOE cross-peaks at different mixing times.
 - Convert the cross-peak volumes to distance restraints using the isolated spin-pair approximation, calibrating with known distances (e.g., sequential $\text{H}\alpha$ -HN).
 - Use the derived distance restraints in a structure calculation protocol (e.g., using Xplor-NIH or CYANA) to determine the three-dimensional structure of the GroEL-bound mobile loop.

Visualization of Experimental Workflow

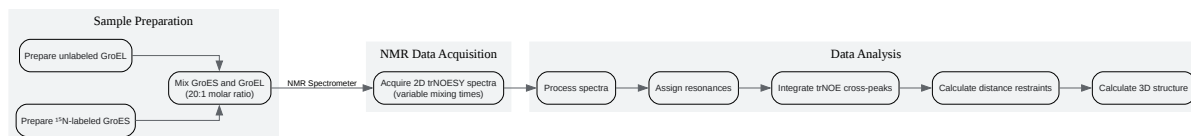

[Click to download full resolution via product page](#)

Caption: Workflow for determining the bound structure of the **GroES mobile loop** using transferred NOE NMR.

Fluorescence Resonance Energy Transfer (FRET)

FRET is a spectroscopic technique that can measure the distance between two fluorescent probes (a donor and an acceptor) when they are in close proximity (typically 1-10 nm). By labeling specific sites on GroES and/or GroEL, FRET can be used to monitor conformational changes and the dynamics of their interaction.

Application Note: Monitoring GroEL-GroES Interaction Dynamics

While placing FRET probes directly on the mobile loop is challenging due to its flexibility and the potential for the probes to interfere with binding, placing them at strategic locations on the bodies of GroES and GroEL can report on the association and dissociation of the complex, which is directly mediated by the mobile loop. Single-molecule FRET (smFRET) is particularly powerful in this context as it can reveal the dynamics of individual complexes, avoiding the ensemble averaging of traditional FRET measurements.

Quantitative Data Summary

Table 3: Representative FRET Efficiency and Calculated Distances for GroEL-GroES Interaction.

These values are illustrative and depend on the specific location of the donor and acceptor probes.

State	Donor Location	Acceptor Location	FRET Efficiency (E)	Apparent Distance (R) (Å)	Interpretation
Unbound	GroEL (apical domain)	GroES (body)	~0.1	> 70	GroEL and GroES are separated
ATP-bound Complex	GroEL (apical domain)	GroES (body)	~0.6	~50	GroEL and GroES are in close proximity

Experimental Protocol: Ensemble FRET

- Protein Engineering and Labeling:
 - Introduce single cysteine mutations at desired locations on GroEL and GroES for site-specific labeling. For example, a site on the apical domain of GroEL and a site on the body of GroES.
 - Purify the mutant proteins.
 - Label one protein with a donor fluorophore (e.g., Alexa Fluor 488 C5 maleimide) and the other with an acceptor fluorophore (e.g., Alexa Fluor 594 C5 maleimide).
 - Remove excess dye by size-exclusion chromatography.
- FRET Measurement:
 - In a fluorometer, mix the labeled GroEL and GroES in a suitable buffer (e.g., 50 mM Tris-HCl, 10 mM MgCl₂, 10 mM KCl, pH 7.5).

- Record the emission spectrum of the donor fluorophore upon excitation at its excitation wavelength.
- Add ATP to induce complex formation and record the emission spectrum again.
- A decrease in donor fluorescence intensity and an increase in acceptor fluorescence intensity (sensitized emission) indicates FRET.
- Data Analysis:
 - Calculate the FRET efficiency (E) using the formula: $E = 1 - (F_{DA} / F_D)$, where F_{DA} is the donor fluorescence in the presence of the acceptor and F_D is the donor fluorescence in the absence of the acceptor.
 - Calculate the apparent distance (R) between the probes using the Förster equation: $R = R_0 * [(1/E) - 1]^{(1/6)}$, where R_0 is the Förster distance for the specific dye pair.

Visualization of Signaling Pathway

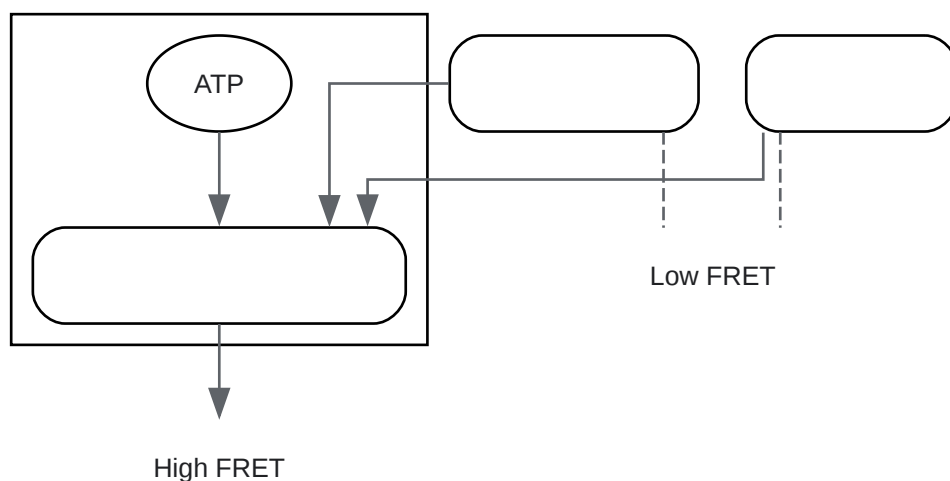

[Click to download full resolution via product page](#)

Caption: FRET signaling pathway for GroEL-GroES interaction.

Hydrogen-Deuterium Exchange Mass Spectrometry (HDX-MS)

HDX-MS measures the rate of exchange of backbone amide hydrogens with deuterium from the solvent. The exchange rate is dependent on the solvent accessibility and hydrogen bonding of the amide protons. This technique can map protein-protein interaction interfaces and detect conformational changes.

Application Note: Mapping the Mobile Loop Binding Interface and Conformational Changes

Upon binding to GroEL, the mobile loop of GroES becomes structured and protected from the solvent. This will result in a significant decrease in the rate of deuterium uptake for peptides within the mobile loop. By comparing the deuterium uptake of GroES in its free and GroEL-bound states, the residues involved in the binding interface and the regions that undergo a disorder-to-order transition can be identified.

Quantitative Data Summary

Table 4: Representative Deuterium Uptake Data for a **GroES Mobile Loop** Peptide.

Time (min)	Deuterium Uptake (Da) - Free GroES	Deuterium Uptake (Da) - GroEL-bound GroES	Difference (Da)	Interpretation
1	4.5	1.2	3.3	Protection upon binding
10	8.2	2.5	5.7	Significant protection
60	12.1	4.8	7.3	Sustained protection

Experimental Protocol: HDX-MS

- Sample Preparation:
 - Prepare solutions of GroES and the GroEL-GroES complex at a concentration of ~10 μM in a suitable H₂O-based buffer (e.g., 20 mM Tris, 150 mM NaCl, pH 7.4).

- Deuterium Labeling:
 - Initiate the exchange reaction by diluting the protein sample 1:10 into a D₂O-based buffer with the same composition.
 - Incubate the reaction for various time points (e.g., 10s, 1 min, 10 min, 1 hr).
- Quenching:
 - Stop the exchange reaction by adding a quench buffer (e.g., 100 mM phosphate, pH 2.5) to lower the pH and temperature (on ice).
- Digestion and LC-MS/MS:
 - Inject the quenched sample into an LC-MS system with an in-line protease column (e.g., pepsin) maintained at low temperature (~0 °C).
 - The protein is rapidly digested into peptides, which are then separated by reverse-phase chromatography and analyzed by mass spectrometry.
 - Perform MS/MS on a non-deuterated sample to identify the peptide sequences.
- Data Analysis:
 - Determine the centroid mass of each peptide at each time point.
 - Calculate the deuterium uptake for each peptide by subtracting the mass of the non-deuterated peptide.
 - Plot the deuterium uptake versus time for each peptide.
 - Compare the uptake plots for free GroES and the GroEL-bound GroES to identify regions of protection.

Visualization of Experimental Workflow

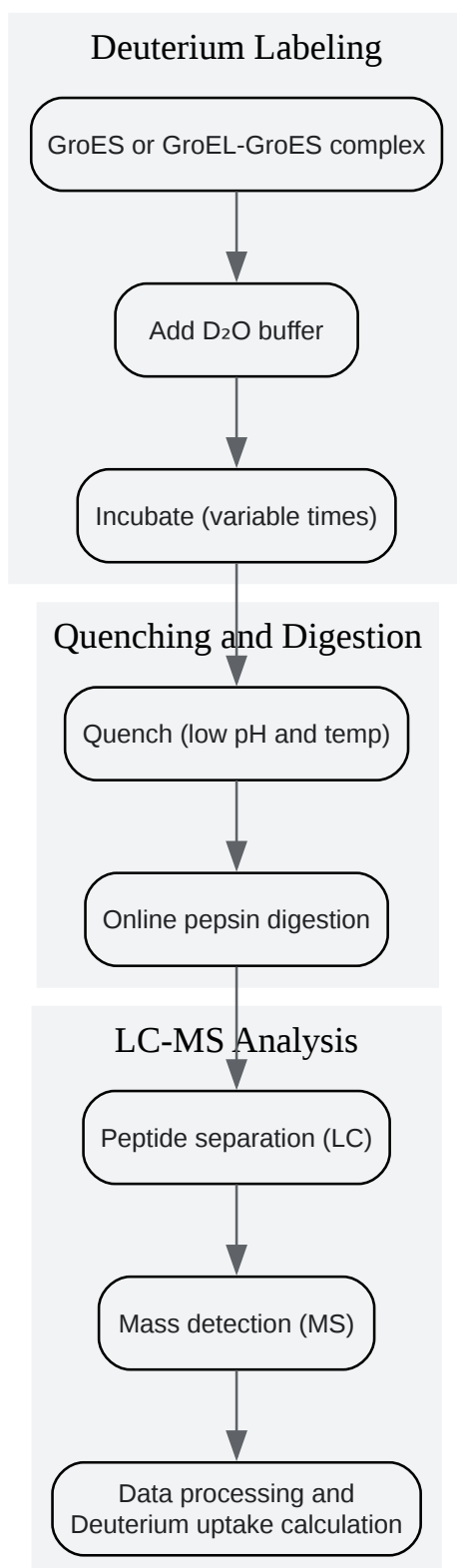

[Click to download full resolution via product page](#)

Caption: Workflow for HDX-MS analysis of **GroES mobile loop** dynamics.

Need Custom Synthesis?

BenchChem offers custom synthesis for rare earth carbides and specific isotopic labeling.

Email: info@benchchem.com or [Request Quote Online](#).

References

- 1. The disordered mobile loop of GroES folds into a defined beta-hairpin upon binding GroEL - PubMed [pubmed.ncbi.nlm.nih.gov]
- To cite this document: BenchChem. [Application Notes and Protocols for Studying GroES Mobile Loop Dynamics in Solution]. BenchChem, [2026]. [Online PDF]. Available at: [<https://www.benchchem.com/product/b15598232/docs#application-notes-and-protocols-for-studying-groes-mobile-loop-dynamics-in-solution>]

Disclaimer & Data Validity:

The information provided in this document is for Research Use Only (RUO) and is strictly not intended for diagnostic or therapeutic procedures. While BenchChem strives to provide accurate protocols, we make no warranties, express or implied, regarding the fitness of this product for every specific experimental setup.

Technical Support: The protocols provided are for reference purposes. Unsure if this reagent suits your experiment?

Need Industrial/Bulk Grade? [Request Custom Synthesis Quote](#)

BenchChem

Our mission is to be the trusted global source of essential and advanced chemicals, empowering scientists and researchers to drive progress in science and industry.

Contact

Address: 3281 E Guasti Rd
Ontario, CA 91761, United States
Phone: (601) 213-4426
Email: info@benchchem.com

Contact our Ph.D. Support Team for a compatibility check