

Application Note: Characterization of H-(Phe)₅-OH using Mass Spectrometry

Author: BenchChem Technical Support Team. **Date:** April 2026

Compound of Interest

Compound Name: *H-Phe-Phe-Phe-Phe-Phe-OH*

Cat. No.: *B15598636*

[Get Quote](#)

For Researchers, Scientists, and Drug Development Professionals

Introduction

H-(Phe)₅-OH, a pentapeptide composed of five phenylalanine residues, serves as a model peptide in various research and development settings, including drug delivery and biomaterial science. Accurate characterization of its molecular weight and primary structure is crucial for ensuring its identity, purity, and functionality. Mass spectrometry is a powerful analytical technique for this purpose, offering high sensitivity and detailed structural information. This application note provides a detailed protocol for the characterization of H-(Phe)₅-OH using Electrospray Ionization Mass Spectrometry (ESI-MS) and Tandem Mass Spectrometry (MS/MS).

Experimental Protocols

Sample Preparation

A stock solution of H-(Phe)₅-OH is prepared by dissolving the lyophilized peptide in a suitable solvent system.

- Materials:

- H-(Phe)5-OH peptide standard
- HPLC-grade water
- HPLC-grade acetonitrile (ACN)
- Formic acid (FA)
- Protocol:
 - Prepare a 1 mg/mL stock solution of H-(Phe)5-OH in 50% acetonitrile/water.
 - For direct infusion analysis, dilute the stock solution to a final concentration of 1-10 μM using a solvent mixture of 50:50 (v/v) acetonitrile:water with 0.1% formic acid. The formic acid aids in the protonation of the peptide, which is essential for positive ion mode ESI-MS.
 - For LC-MS analysis, the sample can be diluted to a similar concentration in the initial mobile phase conditions.

Mass Spectrometry Analysis

The analysis is performed using a high-resolution mass spectrometer equipped with an electrospray ionization source.

- Instrumentation: A quadrupole time-of-flight (Q-TOF) or Orbitrap mass spectrometer is recommended for accurate mass measurements.
- Method:
 - Full Scan MS (MS1): To determine the molecular weight of the intact peptide, a full scan is acquired.
 - Ionization Mode: Positive Electrospray Ionization (ESI+).[1] ESI is a soft ionization technique suitable for analyzing biological macromolecules without fragmentation.[2]
 - Scan Range: m/z 400-1200. This range is selected to encompass the expected protonated molecular ions of the pentapeptide.

- Capillary Voltage: 3.5 - 4.5 kV.
- Source Temperature: 100 - 150 °C.
- Tandem MS (MS/MS): To confirm the amino acid sequence, the protonated molecular ion ($[M+H]^+$) is selected and fragmented.
 - Precursor Ion Selection: The most abundant isotopic peak of the $[M+H]^+$ ion is isolated.
 - Collision Gas: Argon or Nitrogen.
 - Collision Energy: A ramp of collision energies (e.g., 10-40 eV) should be applied to generate a comprehensive fragmentation spectrum. Collision-induced dissociation (CID) is a common method for peptide fragmentation.[3]

Data Presentation

The expected and observed mass spectrometry data for H-(Phe)₅-OH are summarized below.

The theoretical monoisotopic mass of H-(Phe)₅-OH (C₄₅H₄₇N₅O₆) is 765.3527 Da.

| Analysis | Ion | Theoretical m/z | Observed m/z (Example) |
|--|----------------------|-----------------|---------------------------|
| Full Scan MS | [M+H] ⁺ | 766.3600 | 766.3605 |
| | [M+Na] ⁺ | 788.3419 | 788.3423 |
| | [M+2H] ²⁺ | 383.6836 | 383.6839 |
| Tandem MS (Fragmentation of [M+H] ⁺) | y1 | 166.0863 | 166.0865 |
| | b1 | 148.0757 | 148.0759 |
| | y2 | 313.1547 | 313.1550 |
| | b2 | 295.1441 | 295.1443 |
| | y3 | 460.2231 | 460.2235 |
| | b3 | 442.2125 | 442.2128 |
| | y4 | 607.2915 | 607.2919 |
| | b4 | 589.2809 | 589.2812 |

Note: Observed m/z values are hypothetical and will vary slightly based on instrument calibration and resolution.

The fragmentation of peptides in MS/MS typically occurs at the amide bonds, leading to the formation of b- and y-ions, which are diagnostic for the amino acid sequence.^[1] The presence of phenylalanine can influence fragmentation, with potential for neutral losses from the benzyl side chain.^[4]

Diagrams

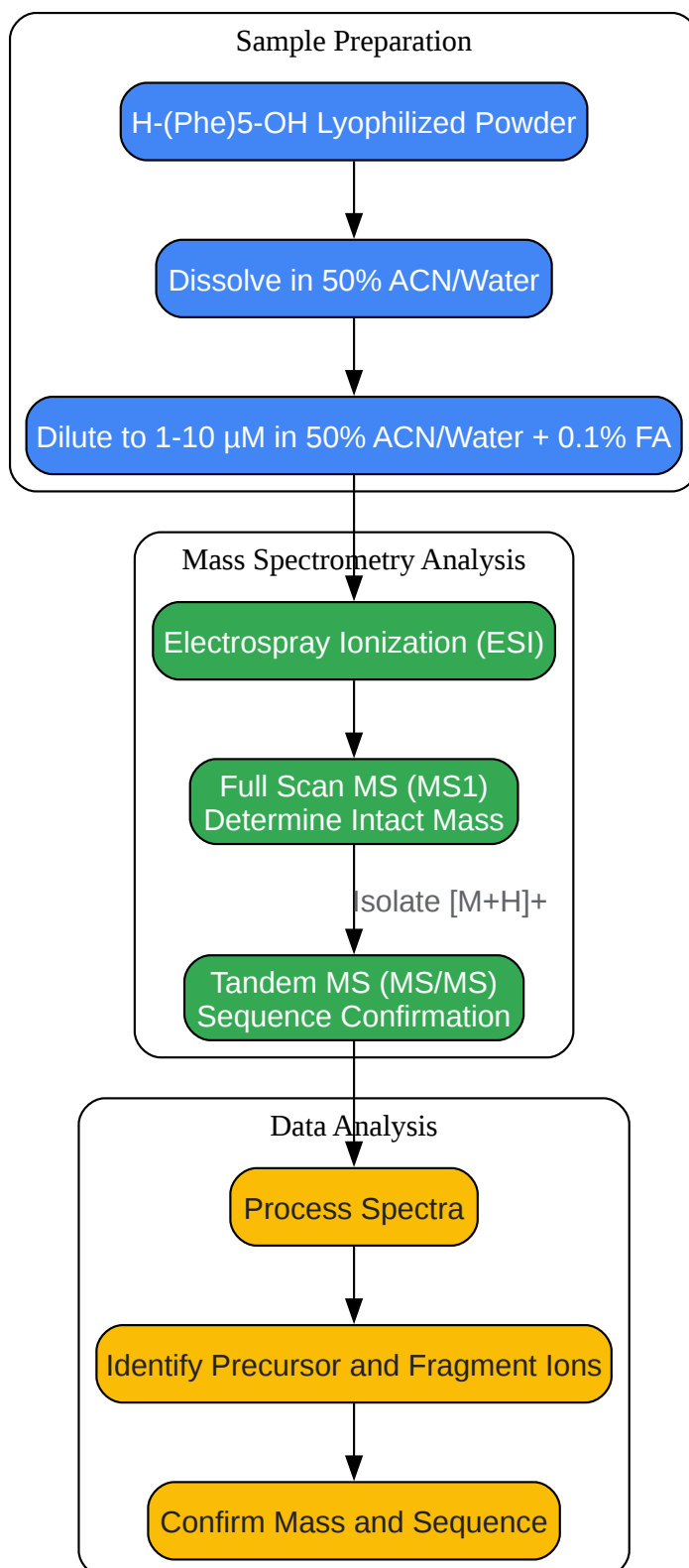

[Click to download full resolution via product page](#)

Caption: Experimental workflow for H-(Phe)5-OH characterization.

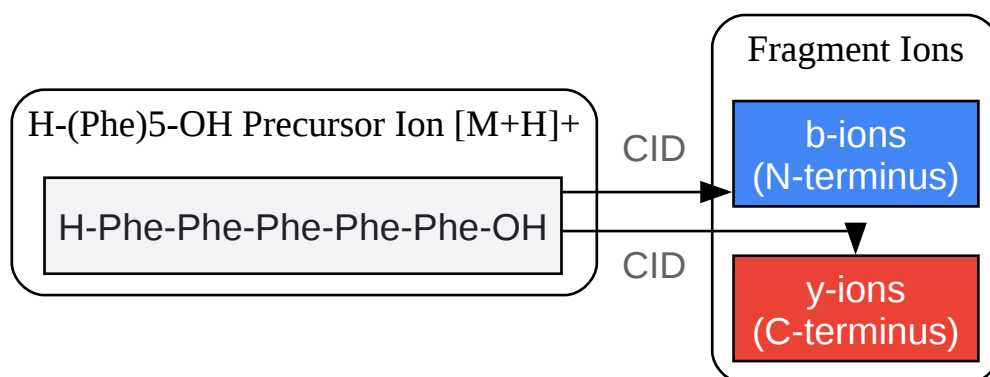

[Click to download full resolution via product page](#)

Caption: Fragmentation of H-(Phe)5-OH into b- and y-ions.

Conclusion

This application note provides a straightforward and reliable protocol for the characterization of the pentapeptide H-(Phe)5-OH using ESI-MS and MS/MS. The detailed methodology for sample preparation and mass spectrometry analysis, along with the expected data, offers a comprehensive guide for researchers. The presented workflow ensures accurate determination of the molecular weight and confirmation of the primary amino acid sequence, which are critical quality attributes for synthetic peptides used in research and development.

Need Custom Synthesis?

BenchChem offers custom synthesis for rare earth carbides and specific isotopic labeling.

Email: info@benchchem.com or [Request Quote Online](#).

References

- [1. benchchem.com \[benchchem.com\]](https://www.benchchem.com)
- [2. chem.libretexts.org \[chem.libretexts.org\]](https://chem.libretexts.org)
- [3. Mass spectrometry of peptides and proteins - PubMed \[pubmed.ncbi.nlm.nih.gov\]](https://pubmed.ncbi.nlm.nih.gov)
- [4. pubs.acs.org \[pubs.acs.org\]](https://pubs.acs.org)

- To cite this document: BenchChem. [Application Note: Characterization of H-(Phe)5-OH using Mass Spectrometry]. BenchChem, [2026]. [Online PDF]. Available at: [<https://www.benchchem.com/product/b15598636/docs#application-note-characterization-of-h-phe-5-oh-using-mass-spectrometry>]

Disclaimer & Data Validity:

The information provided in this document is for Research Use Only (RUO) and is strictly not intended for diagnostic or therapeutic procedures. While BenchChem strives to provide accurate protocols, we make no warranties, express or implied, regarding the fitness of this product for every specific experimental setup.

Technical Support: The protocols provided are for reference purposes. Unsure if this reagent suits your experiment?

Need Industrial/Bulk Grade? [Request Custom Synthesis Quote](#)

BenchChem

Our mission is to be the trusted global source of essential and advanced chemicals, empowering scientists and researchers to drive progress in science and industry.

Contact

Address: 3281 E Guasti Rd
Ontario, CA 91761, United States
Phone: (601) 213-4426
Email: info@benchchem.com

[Contact our Ph.D. Support Team for a compatibility check](#)