

# A Comparative Guide to Chromogenic Substrates for Thrombin and Other Key Proteases

**Author:** BenchChem Technical Support Team. **Date:** April 2026

## Compound of Interest

Compound Name: *Tos-Gly-Pro-Arg-ANBA-IPA*  
acetate

Cat. No.: *B15598042*

[Get Quote](#)

For Researchers, Scientists, and Drug Development Professionals

In the intricate world of biological research and drug development, the precise measurement of protease activity is paramount. Chromogenic substrates offer a straightforward and quantifiable method for these assays. This guide provides a detailed comparison of commonly used chromogenic substrates for four key serine proteases: thrombin, Factor Xa, plasmin, and trypsin. The information presented herein, supported by experimental data and protocols, is intended to assist researchers in selecting the most appropriate substrate for their specific applications.

## Performance Comparison of Chromogenic Substrates

The efficacy of a chromogenic substrate is determined by its kinetic parameters, primarily the Michaelis constant ( $K_m$ ) and the catalytic rate constant ( $k_{cat}$ ) or maximum velocity ( $V_{max}$ ). A lower  $K_m$  value indicates a higher affinity of the enzyme for the substrate, while a higher  $k_{cat}$  or

$V_{max}$  signifies a faster turnover rate. The specificity constant ( $k_{cat}/K_m$ ) is a measure of the overall catalytic efficiency. The following table summarizes the kinetic constants for several widely used chromogenic substrates.

Protease	Substrate	Peptide Sequence	Km ( $\mu\text{M}$ )	Vmax or kcat	Specificity Constant (kcat/Km) ( $\text{s}^{-1}\text{mM}^{-1}$ )
Thrombin	S-2238	H-D-Phe-Pip-Arg-pNA	7[1][2]	1.7 x 10 <sup>-7</sup> mol/min/NIH-U (Human)[1][2]	-
9 (Bovine)[1][2]	2.2 x 10 <sup>-7</sup> mol/min/NIH-U (Bovine)[1][2]	-			
3.65 (Bovine)[3]	15.17 $\mu\text{M}/\text{min}$ (Bovine)[3]	-			
Factor Xa	S-2222	Bz-Ile-Glu-Gly-Arg-pNA	300 (Bovine)[4]	100 s <sup>-1</sup> (Bovine)[4]	333
Plasmin	S-2251	H-D-Val-Leu-Lys-pNA	300 (Human)[5][6]	0.5 x 10 <sup>-6</sup> mol/min/CU[6]	-
Plasminogen-SK Complex	H-D-Val-Leu-Lys-pNA	200[6]	1 x 10 <sup>-6</sup> mol/min/mL plasma[6]	-	
Trypsin	BAPNA	N $\alpha$ -Benzoyl-DL-arginine 4-nitroanilide	120[1]	0.079 mM/min/mg enzyme[1]	-
162[4]	1.62 $\mu\text{M}/\text{h}$ [4]	-			
300 (at RT)	40 mM/min (at RT)	-			
600 (at 37°C)	82 mM/min (at 37°C)	-			
380	3.14 s <sup>-1</sup>	8.26			

Note: Kinetic parameters can vary depending on the experimental conditions (e.g., pH, temperature, buffer composition, and enzyme source). The data presented here is for comparative purposes. pNA refers to p-nitroaniline.

## Experimental Protocols

A generalized protocol for a chromogenic protease assay is provided below, followed by specific conditions for each enzyme-substrate pair.

### General Chromogenic Protease Assay Protocol

- Reagent Preparation:
  - Prepare a stock solution of the chromogenic substrate in an appropriate solvent (e.g., sterile water or DMSO).
  - Prepare a reaction buffer specific to the protease being assayed.
  - Prepare a stock solution of the purified protease in a suitable buffer.
- Assay Procedure:
  - In a 96-well microplate, add the reaction buffer.
  - Add the protease solution to the wells.
  - Pre-incubate the plate at the optimal temperature for the enzyme (e.g., 37°C).
  - Initiate the reaction by adding the chromogenic substrate solution to each well.
  - Immediately measure the absorbance at 405 nm using a microplate reader.
  - Continue to record the absorbance at regular intervals (e.g., every minute) for a set period.
- Data Analysis:
  - Calculate the rate of reaction ( $\Delta A/\text{min}$ ) from the linear portion of the absorbance versus time curve.

- The enzyme activity is proportional to the rate of p-nitroaniline release.

## Specific Assay Conditions

- Thrombin (S-2238):
  - Buffer: 50 mM Tris-HCl, pH 8.3, containing 0.15 M NaCl.[1][2]
  - Substrate Concentration: Typically 0.1 mM.[2]
  - Temperature: 37°C.[1][2]
- Factor Xa (S-2222):
  - Buffer: 50 mM Tris-HCl, pH 8.3, with an ionic strength of 0.25.[4]
  - Substrate Concentration: Typically twice the  $K_m$  value.
  - Temperature: 37°C.[4]
- Plasmin (S-2251):
  - Buffer: 50 mM Tris-HCl, pH 7.4, with an ionic strength of 0.5.[6]
  - Substrate Concentration: Typically twice the  $K_m$  value.[6]
  - Temperature: 37°C.[6]
- Trypsin (BAPNA):
  - Buffer: 100 mM Tris-HCl, pH 8.2, containing 20 mM  $\text{CaCl}_2$ .
  - Substrate Concentration: Ranging from 0.25 to 0.8 mM.[4]
  - Temperature: 25°C or 37°C.

## Signaling Pathways and Experimental Workflow

To provide a broader context for the application of these proteases and their substrates, the following diagrams illustrate their key signaling pathways and a typical experimental workflow.

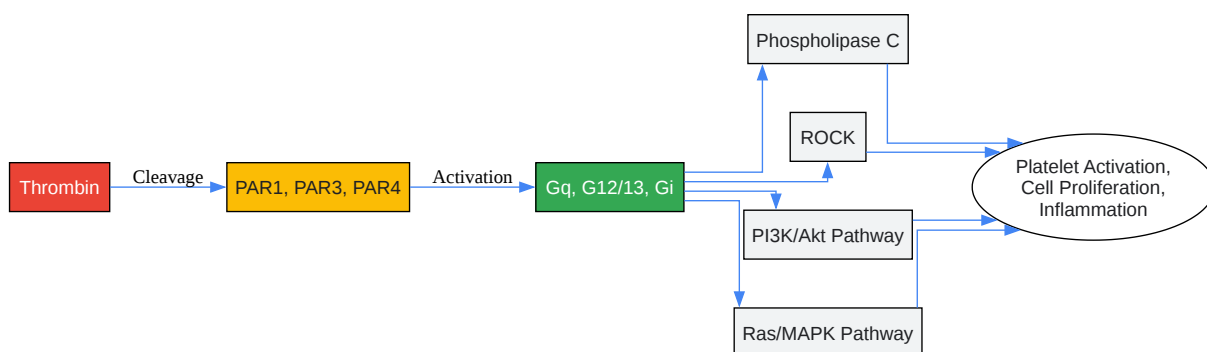

[Click to download full resolution via product page](#)

Caption: Thrombin signaling cascade via Protease-Activated Receptors (PARs).

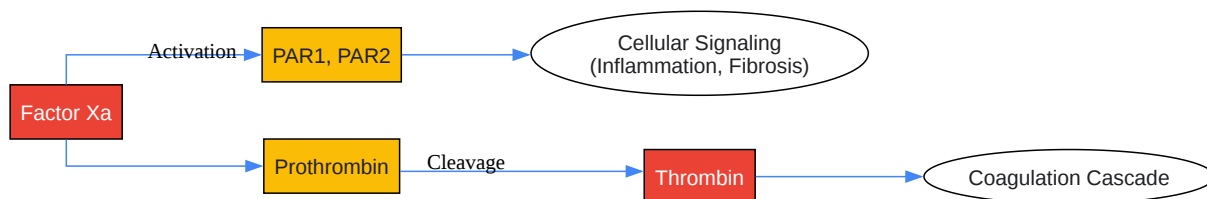

[Click to download full resolution via product page](#)

Caption: Dual role of Factor Xa in coagulation and cellular signaling.

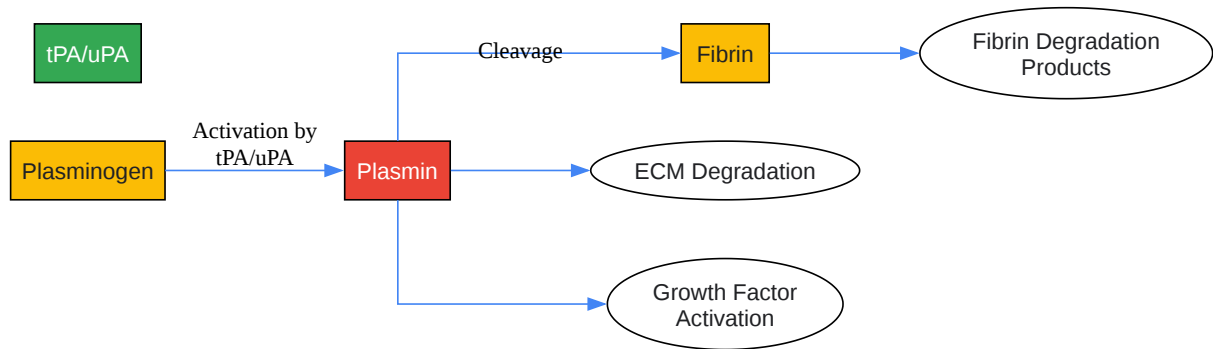

[Click to download full resolution via product page](#)

Caption: Plasmin's central role in fibrinolysis and tissue remodeling.

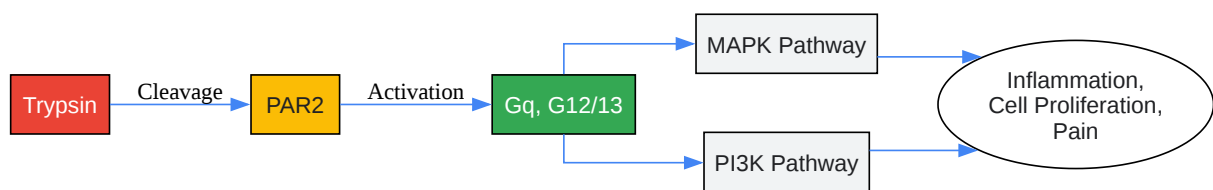

[Click to download full resolution via product page](#)

Caption: Trypsin signaling primarily through Protease-Activated Receptor 2 (PAR2).

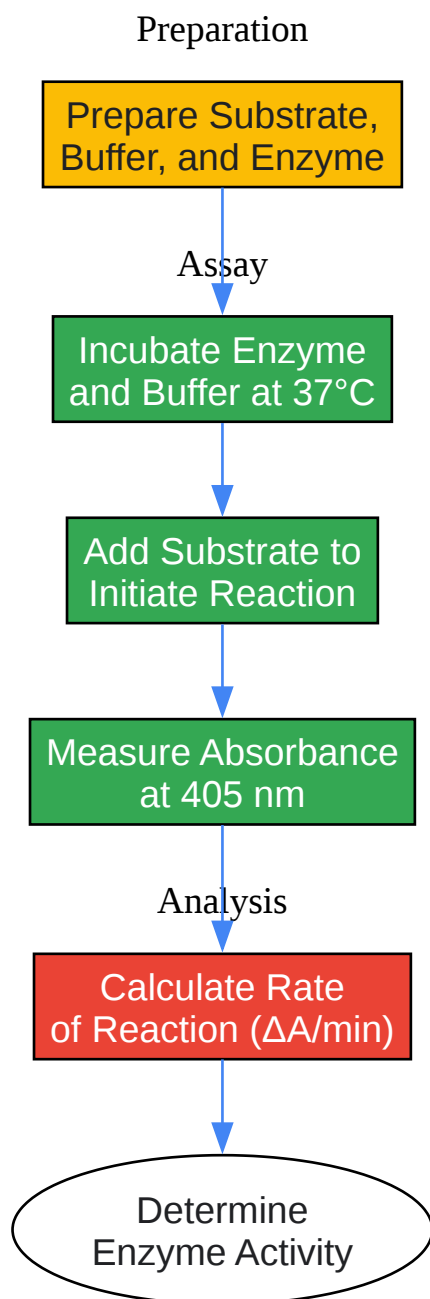

[Click to download full resolution via product page](#)

Caption: General workflow for a chromogenic protease assay.

#### Need Custom Synthesis?

BenchChem offers custom synthesis for rare earth carbides and specific isotopic labeling.

Email: [info@benchchem.com](mailto:info@benchchem.com) or [Request Quote Online](#).

## References

- [1. On-line characterization of the activity and reaction kinetics of immobilized enzyme by high-performance frontal analysis - PubMed \[pubmed.ncbi.nlm.nih.gov\]](#)
- [2. sigmaaldrich.com \[sigmaaldrich.com\]](#)
- [3. researchgate.net \[researchgate.net\]](#)
- [4. researchgate.net \[researchgate.net\]](#)
- [5. Comparison of soluble and immobilized trypsin kinetics: Implications for peptide synthesis - PubMed \[pubmed.ncbi.nlm.nih.gov\]](#)
- [6. researchgate.net \[researchgate.net\]](#)
- To cite this document: BenchChem. [A Comparative Guide to Chromogenic Substrates for Thrombin and Other Key Proteases]. BenchChem, [2026]. [Online PDF]. Available at: [\[https://www.benchchem.com/product/b15598042/docs#a-comparative-guide-to-chromogenic-substrates-for-thrombin-and-other-key-proteases\]](https://www.benchchem.com/product/b15598042/docs#a-comparative-guide-to-chromogenic-substrates-for-thrombin-and-other-key-proteases)

---

### Disclaimer & Data Validity:

The information provided in this document is for Research Use Only (RUO) and is strictly not intended for diagnostic or therapeutic procedures. While BenchChem strives to provide accurate protocols, we make no warranties, express or implied, regarding the fitness of this product for every specific experimental setup.

**Technical Support:** The protocols provided are for reference purposes. Unsure if this reagent suits your experiment?

**Need Industrial/Bulk Grade?** [Request Custom Synthesis Quote](#)

## BenchChem

Our mission is to be the trusted global source of essential and advanced chemicals, empowering scientists and researchers to drive progress in science and industry.

### Contact

Address: 3281 E Guasti Rd  
Ontario, CA 91761, United States  
Phone: (601) 213-4426  
Email: [info@benchchem.com](mailto:info@benchchem.com)

Contact our Ph.D. Support Team for a compatibility check