

basic principles of OVA (329-337) T-cell stimulation

Author: BenchChem Technical Support Team. **Date:** April 2026

Compound of Interest

Compound Name: OVA (329-337)

Cat. No.: B15597860

[Get Quote](#)

An In-depth Technical Guide to the Core Principles of Ovalbumin (OVA) Peptide T-Cell Stimulation

Introduction

In the field of immunology, the chicken ovalbumin (OVA) protein serves as a cornerstone model antigen for studying the adaptive immune response. Its well-characterized peptide epitopes are instrumental in dissecting the mechanisms of antigen processing, presentation, and the subsequent activation of T-lymphocytes. This guide focuses on the fundamental principles of T-cell stimulation using two of the most widely studied OVA-derived peptides: **OVA (329-337)** for CD4+ T-helper cells and OVA (257-264) for CD8+ cytotoxic T-lymphocytes.

Understanding these interactions is critical for researchers, scientists, and drug development professionals engaged in vaccine development, cancer immunotherapy, and autoimmune disease research. This document provides a technical overview of the key cellular components, signaling pathways, experimental protocols, and quantitative parameters that govern OVA-specific T-cell activation.

Core Components of OVA T-Cell Stimulation

T-cell activation is a highly specific process initiated by the interaction between a T-cell receptor (TCR) and a peptide-Major Histocompatibility Complex (pMHC) on the surface of an Antigen Presenting Cell (APC).

- T-Lymphocytes: The primary responders are T-cells, often sourced from T-cell receptor (TCR) transgenic mouse models that express a uniform TCR specific for an OVA peptide.
 - OT-II and DO11.10: These models are specific for the OVA peptide 323-339 presented on the MHC class II molecule I-A. The core epitope recognized is often cited as residues 329-337.[\[1\]](#)[\[2\]](#)[\[3\]](#) These are CD4+ T-cells.
 - OT-I: This model expresses a TCR specific for the OVA peptide 257-264 (SIINFEKL) presented on the MHC class I molecule H-2Kb.[\[4\]](#) These are CD8+ T-cells.
- Antigen Presenting Cells (APCs): These cells process the OVA protein or are loaded with specific OVA peptides and present them to T-cells.
 - Dendritic Cells (DCs): Considered the most potent APCs for activating naïve T-cells.[\[5\]](#)
 - B-cells and Macrophages: Also capable of presenting antigens and activating T-cells.
- OVA Peptides: These are the specific antigenic determinants recognized by the TCR. The context of the full protein is complex, as a single peptide sequence like OVA 323-339 can bind to the MHC in multiple ways, known as registers.[\[2\]](#)[\[6\]](#)[\[7\]](#)

Component	Description	Sequence	Specificity	Reference
CD4+ T-Cell Epitope	A core MHC Class II-restricted epitope from ovalbumin.	AAHAEINEA	OT-II / DO11.10 TCR (I-Ab / I-Ad)	[1] [8]
CD8+ T-Cell Epitope	The immunodominant MHC Class I-restricted epitope from ovalbumin.	SIINFEKL	OT-I TCR (H-2Kb)	[4] [9]

The Two-Signal Model of T-Cell Activation

Full activation of a naïve T-cell requires two distinct signals from the APC. The absence of the second signal can lead to anergy (a state of non-responsiveness) or tolerance.

- **Signal 1 (Antigen-Specific):** The primary signal is delivered through the binding of the TCR and its co-receptor (CD4 or CD8) to the specific pMHC on the APC surface.
- **Signal 2 (Co-stimulatory):** A crucial secondary signal is provided by the interaction of co-stimulatory molecules. The most prominent example is the binding of CD28 on the T-cell to CD80 (B7-1) or CD86 (B7-2) on the APC.

This dual-signal requirement ensures that T-cells are only activated by legitimate threats presented by professional APCs.

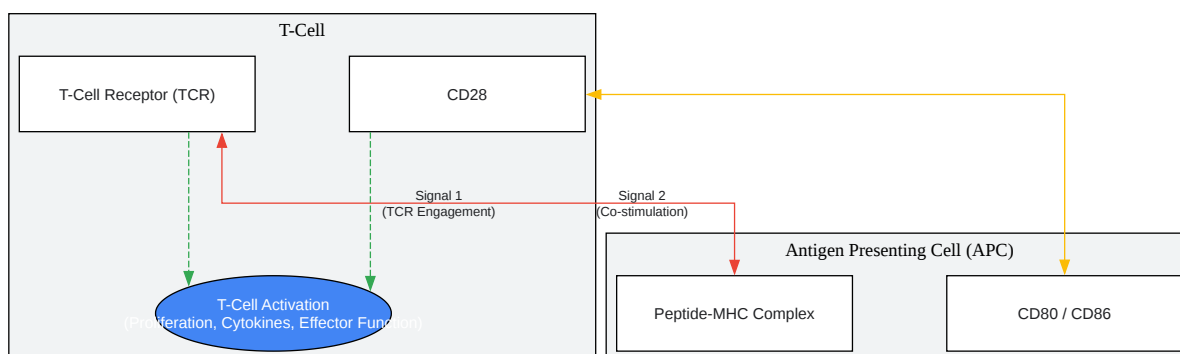

[Click to download full resolution via product page](#)

Diagram 1: The two-signal model for T-cell activation.

TCR Signaling Pathway

Upon successful pMHC engagement and co-stimulation, a complex intracellular signaling cascade is initiated within the T-cell. This cascade amplifies the initial signal and culminates in the activation of transcription factors that drive the cellular changes associated with activation.

Key events include:

- Phosphorylation of immunoreceptor tyrosine-based activation motifs (ITAMs) in the CD3 complex by Lck.
- Recruitment and activation of ZAP-70.
- Formation of a signalosome involving adapter proteins like LAT and SLP-76.
- Activation of downstream pathways including PLC γ , which leads to calcium influx and DAG production, ultimately activating transcription factors like NFAT, AP-1, and NF- κ B.

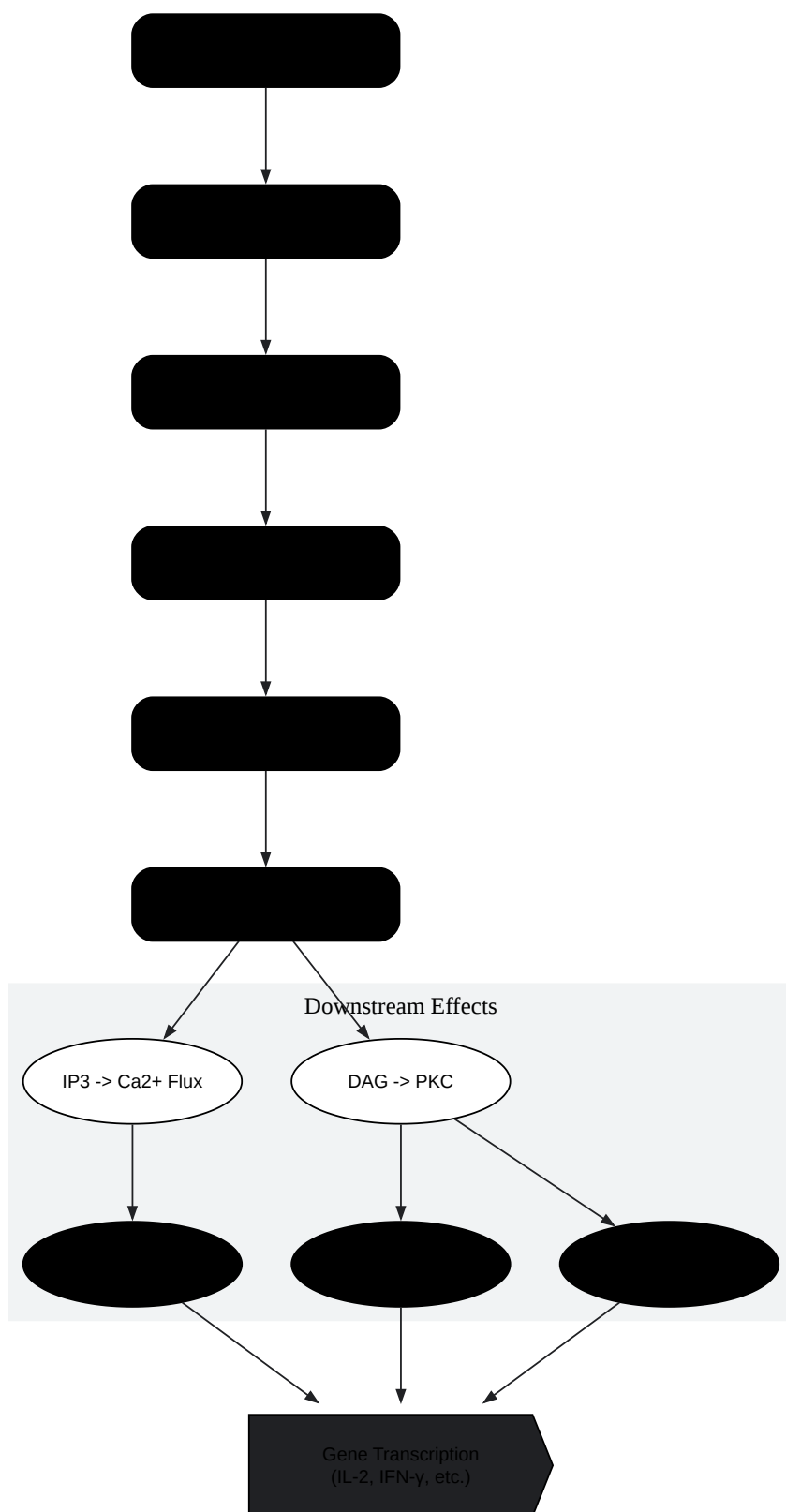

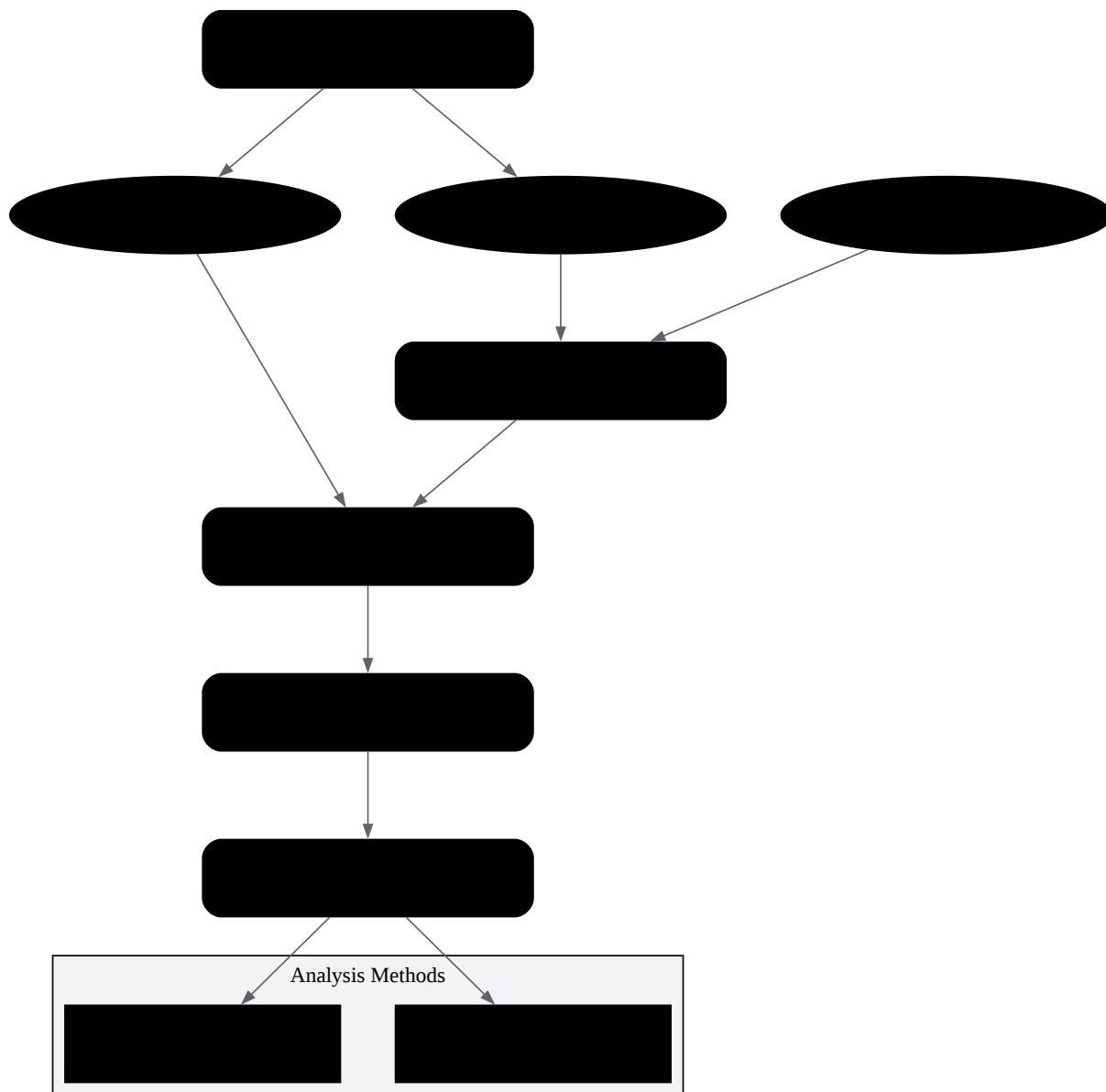

[Click to download full resolution via product page](#)

Need Custom Synthesis?

BenchChem offers custom synthesis for rare earth carbides and specific isotopic labeling.

Email: info@benchchem.com or [Request Quote Online](#).

References

- 1. DO11.10 and OT-II T cells recognize a C-terminal ovalbumin 323-339 epitope - PubMed [pubmed.ncbi.nlm.nih.gov]
- 2. Flanking Residues Are Central to DO11.10 T Cell Hybridoma Stimulation by Ovalbumin 323–339 | PLOS One [journals.plos.org]
- 3. researchgate.net [researchgate.net]
- 4. Antigen-Specific Stimulation of CD8+ T-cells by Murine Bone Marrow-Derived Dendritic Cells - National Cancer Institute's Nanotechnology Characterization Laboratory Assay Cascade Protocols - NCBI Bookshelf [ncbi.nlm.nih.gov]
- 5. antibody-creativebiolabs.com [antibody-creativebiolabs.com]
- 6. Flanking Residues Are Central to DO11.10 T Cell Hybridoma Stimulation by Ovalbumin 323–339 - PMC [pmc.ncbi.nlm.nih.gov]
- 7. New Design of MHC Class II Tetramers to Accommodate Fundamental Principles of Antigen Presentation - PMC [pmc.ncbi.nlm.nih.gov]
- 8. I-Ab | chicken ova 329-337 | AAHA EINEA | NIH Tetramer Core Facility [tetramer.yerkes.emory.edu]
- 9. medchemexpress.com [medchemexpress.com]
- To cite this document: BenchChem. [basic principles of OVA (329-337) T-cell stimulation]. BenchChem, [2026]. [Online PDF]. Available at: [<https://www.benchchem.com/product/b15597860/docs#basic-principles-of-ova-329-337-t-cell-stimulation>]

Disclaimer & Data Validity:

The information provided in this document is for Research Use Only (RUO) and is strictly not intended for diagnostic or therapeutic procedures. While BenchChem strives to provide

accurate protocols, we make no warranties, express or implied, regarding the fitness of this product for every specific experimental setup.

Technical Support: The protocols provided are for reference purposes. Unsure if this reagent suits your experiment?

Need Industrial/Bulk Grade? [Request Custom Synthesis Quote](#)

BenchChem

Our mission is to be the trusted global source of essential and advanced chemicals, empowering scientists and researchers to drive progress in science and industry.

Contact

Address: 3281 E Guasti Rd

Ontario, CA 91761, United States

Phone: (601) 213-4426

Email: info@benchchem.com

[Contact our Ph.D. Support Team for a compatibility check](#)