

# Technical Support Center: Quantifying Endogenous SHLP-4

**Author:** BenchChem Technical Support Team. **Date:** April 2026

## Compound of Interest

Compound Name: SHLP-4  
Cat. No.: B15597951

[Get Quote](#)

Welcome to the technical support center for the quantification of endogenous Small Humanin-Like Peptide 4 (**SHLP-4**). This resource is designed for researchers, scientists, and drug development professionals to provide guidance on overcoming the challenges associated with measuring this novel mitochondrial-derived peptide.

## Frequently Asked Questions (FAQs)

Q1: What is **SHLP-4** and why is it challenging to quantify?

A1: **SHLP-4** is a recently discovered microprotein encoded by the mitochondrial 16S rRNA gene. Its small size (26 amino acids), potential for low endogenous expression in certain tissues, and sequence similarity to other mitochondrial peptides present significant quantification challenges. These factors can lead to issues with antibody specificity, assay sensitivity, and overall reproducibility.

Q2: Which tissues have been reported to express endogenous **SHLP-4**?

A2: Endogenous **SHLP-4** has been detected in various mouse tissues, with notable expression in the liver and prostate.<sup>[1]</sup> Its expression can vary significantly between different organs.<sup>[1]</sup>

Q3: What are the primary methods for quantifying endogenous **SHLP-4**?

A3: The two primary methods for quantifying endogenous peptides like **SHLP-4** are Enzyme-Linked Immunosorbent Assay (ELISA) and Liquid Chromatography-Mass Spectrometry (LC-MS/MS). Each method has its own set of advantages and challenges.

Q4: Are there commercially available ELISA kits for **SHLP-4**?

A4: Currently, there are no widely available, validated commercial ELISA kits specifically for the quantification of endogenous **SHLP-4**. Researchers often need to develop and validate their own assays.

Q5: What are the key considerations for developing an in-house **SHLP-4** ELISA?

A5: Key considerations include:

- **Antibody Specificity:** The most critical factor is the development of highly specific monoclonal or polyclonal antibodies that can distinguish **SHLP-4** from other SHLP family members and mitochondrial peptides.
- **Assay Sensitivity:** Due to the potentially low physiological concentrations of **SHLP-4**, a highly sensitive assay format (e.g., a sandwich ELISA) is recommended.
- **Matrix Effects:** Biological samples (e.g., plasma, tissue homogenates) contain numerous substances that can interfere with the assay. Proper sample preparation and validation are crucial to minimize these effects.
- **Standard Curve:** A well-characterized synthetic **SHLP-4** peptide is required to generate a reliable standard curve for accurate quantification.

## Troubleshooting Guides

### ELISA Troubleshooting for **SHLP-4** Quantification

Problem	Potential Cause	Recommended Solution
No or Weak Signal	Low abundance of SHLP-4 in the sample.	Increase the amount of sample used. <sup>[2]</sup> Consider using a more sensitive detection system.
Poor antibody binding.	Optimize antibody concentrations (both capture and detection). <sup>[2]</sup> Ensure the antibody is validated for ELISA and is specific to SHLP-4.	
Inadequate incubation times or temperatures.	Increase incubation times or optimize temperature as per antibody manufacturer's recommendations. <sup>[2]</sup>	
Inactive enzyme conjugate or substrate.	Use fresh reagents and ensure proper storage conditions.	
High Background	Non-specific antibody binding.	Use a high-quality blocking buffer (e.g., 5% BSA or non-fat dry milk in TBST). <sup>[3]</sup> Increase the number and duration of wash steps. <sup>[4]</sup>
Cross-reactivity of the detection antibody.	Use a highly specific secondary antibody and include appropriate controls.	
Contaminated reagents or buffers.	Prepare fresh buffers and reagents. <sup>[4]</sup>	
Poor Reproducibility (High CV%)	Pipetting errors or inconsistent technique.	Ensure pipettes are calibrated and use consistent pipetting techniques. <sup>[2]</sup> Use at least duplicate wells for all samples and standards.

---

Incomplete mixing of reagents.	Thoroughly mix all reagents before use.
--------------------------------	---

---

Edge effects on the plate.	Avoid using the outer wells of the plate if temperature gradients are suspected. Ensure uniform incubation temperature.
----------------------------	--

---

## Mass Spectrometry (LC-MS/MS) Troubleshooting for SHLP-4 Quantification

Problem	Potential Cause	Recommended Solution
Low Signal Intensity / Poor Sensitivity	Inefficient ionization of the peptide.	Optimize electrospray ionization (ESI) source parameters (e.g., spray voltage, gas flow, temperature).
Poor fragmentation of the precursor ion.	Optimize collision energy for the specific precursor-to-product ion transitions.	
Sample loss during preparation.	Use low-binding tubes and pipette tips. <sup>[5]</sup> Optimize the extraction protocol to maximize recovery.	
Matrix suppression.	Improve chromatographic separation to resolve SHLP-4 from interfering matrix components. Consider using a more effective sample cleanup method like solid-phase extraction (SPE).	
Poor Peak Shape (Tailing or Broadening)	Inappropriate chromatographic conditions.	Optimize the mobile phase composition, gradient, and column temperature. Use a column with a suitable pore size for peptides (e.g., 300 Å).
Non-specific binding to the LC system.	Add a small percentage of an organic acid (e.g., formic acid) to the mobile phase. Consider using a column with a different chemistry.	
Inconsistent Retention Time	Unstable LC pump flow rate.	Ensure the LC system is properly maintained and calibrated.

---

Changes in mobile phase composition.	Prepare fresh mobile phase daily and ensure it is thoroughly degassed.
--------------------------------------	--

---

## Experimental Protocols

### General Protocol for **SHLP-4** Sandwich ELISA

#### Development

- Plate Coating: Coat a 96-well microplate with a capture antibody specific for **SHLP-4** (e.g., 1-5 µg/mL in a suitable coating buffer like carbonate-bicarbonate buffer, pH 9.6). Incubate overnight at 4°C.
- Washing: Wash the plate 3-5 times with a wash buffer (e.g., PBS with 0.05% Tween-20).
- Blocking: Block the plate with a blocking buffer (e.g., 5% BSA in PBST) for 1-2 hours at room temperature to prevent non-specific binding.
- Washing: Repeat the wash step.
- Sample and Standard Incubation: Add prepared standards (synthetic **SHLP-4**) and samples to the wells. Incubate for 2 hours at room temperature or overnight at 4°C.
- Washing: Repeat the wash step.
- Detection Antibody Incubation: Add a biotinylated detection antibody specific for a different epitope on **SHLP-4**. Incubate for 1-2 hours at room temperature.
- Washing: Repeat the wash step.
- Enzyme Conjugate Incubation: Add a streptavidin-horseradish peroxidase (HRP) conjugate and incubate for 30-60 minutes at room temperature.
- Washing: Repeat the wash step.
- Substrate Addition: Add a suitable HRP substrate (e.g., TMB) and incubate in the dark until color develops.

- Stop Reaction: Stop the reaction with a stop solution (e.g., 2N H<sub>2</sub>SO<sub>4</sub>).
- Read Plate: Read the absorbance at the appropriate wavelength (e.g., 450 nm for TMB).

## General Workflow for SHLP-4 Quantification by LC-MS/MS

- Sample Preparation:
  - Tissue Homogenization: Homogenize tissue samples in a suitable lysis buffer containing protease inhibitors.
  - Protein Precipitation: Precipitate larger proteins from plasma or tissue homogenates using an organic solvent (e.g., acetonitrile).
  - Solid-Phase Extraction (SPE): Further purify and concentrate the peptide fraction using a suitable SPE cartridge.
  - Internal Standard Spiking: Spike the sample with a stable isotope-labeled (SIL) **SHLP-4** internal standard for accurate quantification.
- LC Separation:
  - Inject the prepared sample onto a reverse-phase HPLC column suitable for peptide separations (e.g., C18, 300 Å pore size).
  - Use a gradient of increasing organic solvent (e.g., acetonitrile with 0.1% formic acid) to elute the peptides.
- MS/MS Detection:
  - Introduce the eluent into a tandem mass spectrometer equipped with an electrospray ionization (ESI) source.
  - Operate the mass spectrometer in Multiple Reaction Monitoring (MRM) mode.
  - Select the precursor ion corresponding to the m/z of **SHLP-4** and its SIL internal standard.

- Fragment the precursor ions and monitor specific product ions for both the endogenous peptide and the internal standard.
- Data Analysis:
  - Integrate the peak areas of the MRM transitions for both endogenous **SHLP-4** and the SIL internal standard.
  - Calculate the concentration of endogenous **SHLP-4** by comparing the peak area ratio to a standard curve generated with known concentrations of synthetic **SHLP-4**.

## Quantitative Data Summary

Currently, there is a lack of published, peer-reviewed data on the absolute quantitative levels of endogenous **SHLP-4** in various biological samples. However, data from a related mitochondrial peptide, SHLP-2, can provide an approximate frame of reference.

Table 1: Reported Endogenous Levels of SHLP-2 in Human Plasma

Condition	Mean Concentration (pg/mL)	Reference
Healthy White Men	393	[3]
White Men with Prostate Cancer	196	[3]
Healthy Black Men	290	[3]

Note: These values are for SHLP-2 and may not be representative of **SHLP-4** concentrations. This table is provided for illustrative purposes to indicate the potential low pg/mL range of these peptides.

## Visualizations

### SHLP-4 Signaling Pathway

**SHLP-4** is suggested to be involved in cellular signaling, potentially through the activation of the ERK and STAT3 pathways, similar to other SHLPs.[6] The exact receptor for **SHLP-4** has not yet been identified.

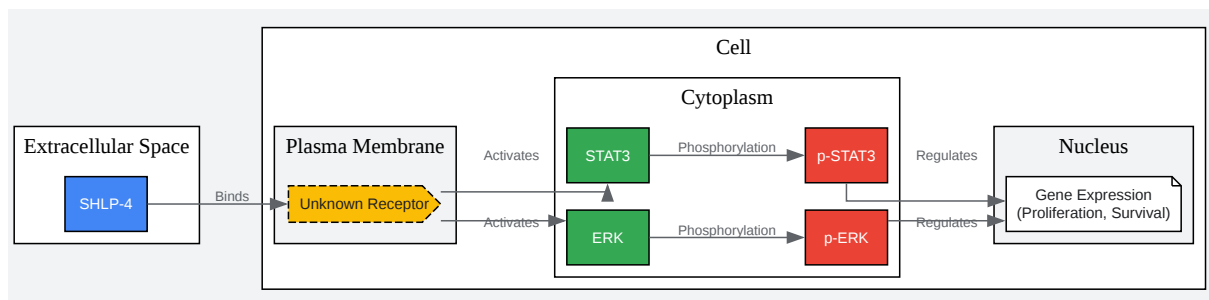

[Click to download full resolution via product page](#)

Caption: Putative signaling pathway of **SHLP-4**, leading to the activation of ERK and STAT3.

## Experimental Workflow for **SHLP-4** Quantification by LC-MS/MS

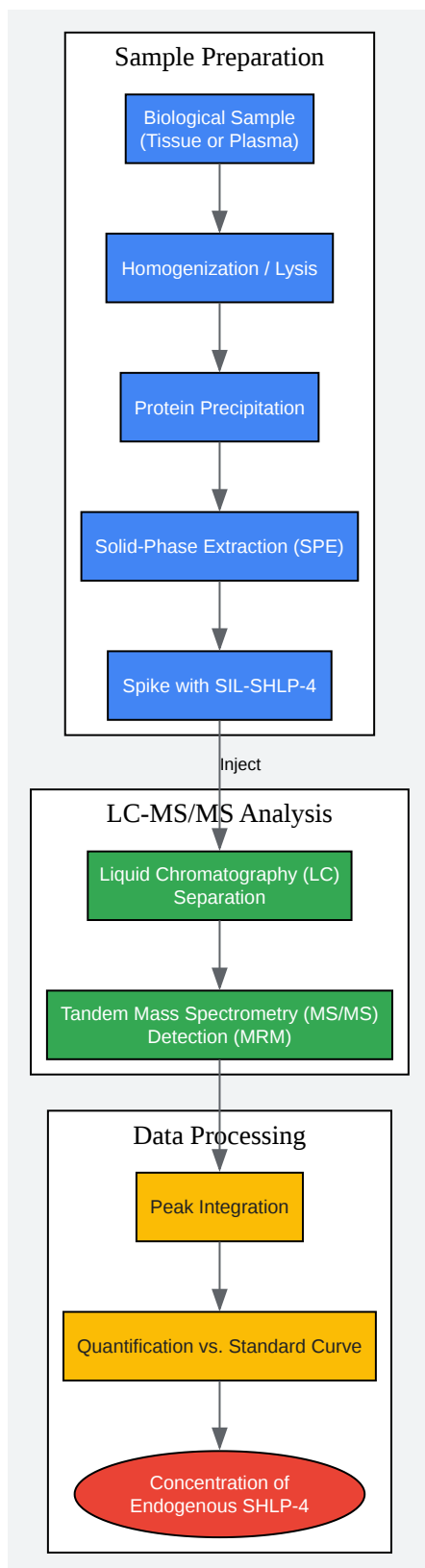

[Click to download full resolution via product page](#)

Caption: General workflow for the quantification of endogenous **SHLP-4** using LC-MS/MS.

### Need Custom Synthesis?

BenchChem offers custom synthesis for rare earth carbides and specific isotopic labeling.

Email: [info@benchchem.com](mailto:info@benchchem.com) or [Request Quote Online](#).

## References

- 1. Naturally occurring mitochondrial-derived peptides are age-dependent regulators of apoptosis, insulin sensitivity, and inflammatory markers - PMC [pmc.ncbi.nlm.nih.gov]
- 2. [hycultbiotech.com](https://www.hycultbiotech.com) [hycultbiotech.com]
- 3. [biocompare.com](https://www.biocompare.com) [biocompare.com]
- 4. ELISA Troubleshooting Guide: Common Questions, Tips & Tricks | R&D Systems [rndsystems.com]
- 5. [waters.com](https://www.waters.com) [waters.com]
- 6. [alzdiscovery.org](https://www.alzdiscovery.org) [alzdiscovery.org]
- To cite this document: BenchChem. [Technical Support Center: Quantifying Endogenous SHLP-4]. BenchChem, [2026]. [Online PDF]. Available at: [https://www.benchchem.com/product/b15597951/docs#technical-support-center-quantifying-endogenous-shlp-4]

---

### Disclaimer & Data Validity:

The information provided in this document is for Research Use Only (RUO) and is strictly not intended for diagnostic or therapeutic procedures. While BenchChem strives to provide accurate protocols, we make no warranties, express or implied, regarding the fitness of this product for every specific experimental setup.

**Technical Support:** The protocols provided are for reference purposes. Unsure if this reagent suits your experiment?

**Need Industrial/Bulk Grade?** [Request Custom Synthesis Quote](#)

# BenchChem

Our mission is to be the trusted global source of essential and advanced chemicals, empowering scientists and researchers to drive progress in science and industry.

## Contact

Address: 3281 E Guasti Rd

Ontario, CA 91761, United States

Phone: (601) 213-4426

Email: [info@benchchem.com](mailto:info@benchchem.com)

[Contact our Ph.D. Support Team for a compatibility check](#)