

Application Notes and Protocols for Step-by-Step NODAGA-RGD Radiolabeling

Author: BenchChem Technical Support Team. **Date:** April 2026

Compound of Interest

Compound Name:	Nodaga-rgd
CAS No.:	1414595-49-5
Cat. No.:	B15597843

[Get Quote](#)

For Researchers, Scientists, and Drug Development Professionals

These application notes provide a detailed, step-by-step protocol for the radiolabeling of **NODAGA-RGD** with Gallium-68 (^{68}Ga), a critical procedure for the preparation of a radiopharmaceutical used in Positron Emission Tomography (PET) imaging of $\alpha\beta3$ integrin expression. This protocol is intended for research and drug development professionals with experience in handling radioactive materials and standard laboratory procedures.

Introduction

Radiolabeled Arginine-Glycine-Aspartic acid (RGD) peptides are invaluable tools for the non-invasive imaging of angiogenesis and tumor progression.[1] The $\alpha\beta3$ integrin, a cell surface receptor, is a key biomarker in these processes as it is overexpressed on activated endothelial cells and various tumor cells.[2] The chelator 1,4,7-triazacyclononane,1-glutaric acid-4,7-diacetic acid (NODAGA) offers facile and efficient labeling with radiometals like Gallium-68.[3] ^{68}Ga -**NODAGA-RGD** has demonstrated favorable pharmacokinetics and imaging properties, making it a promising tracer for clinical applications.[4][5]

Experimental Protocols

This section details the materials and step-by-step procedure for the manual radiolabeling of **NODAGA-RGD** with ^{68}Ga . Automated synthesis modules can also be used and have been shown to produce ^{68}Ga -**NODAGA-RGD** efficiently.[6]

Materials and Reagents

- NODAGA-c(RGDyK) or NODAGA-c(RGDfK) peptide (e.g., from ABX GmbH)
- $^{68}\text{Ge}/^{68}\text{Ga}$ generator (e.g., from Pars Isotope Co. or ITG)
- 0.1 M Hydrochloric acid (HCl), metal-free
- Sodium acetate buffer (e.g., 1 M, pH 4.5 or 2 M, pH 5.0) or Ammonium acetate buffer (e.g., 3 M, pH 4)
- Ethanol (50% v/v in water for injection)
- Saline solution (0.9% NaCl), sterile
- Solid Phase Extraction (SPE) cartridges (e.g., Sep-Pak C18)
- Sterile filters (0.22 μm pore size)
- Reaction vials (e.g., Eppendorf tubes)
- Heating block or water bath
- Dose calibrator
- Radio-Thin Layer Chromatography (radio-TLC) system
- Radio-High-Performance Liquid Chromatography (radio-HPLC) system

Step-by-Step Radiolabeling Procedure

The following protocol is a synthesis of commonly employed manual labeling methods.[1][6][7]

- Elution of ^{68}Ga : Elute the $^{68}\text{Ge}/^{68}\text{Ga}$ generator with 0.1 M HCl according to the manufacturer's instructions to obtain $^{68}\text{GaCl}_3$ in an acidic solution. The eluted activity can range from approximately 60 to 1295 MBq.[1][7]
- Buffering the Reaction Mixture:
 - Transfer the $^{68}\text{GaCl}_3$ eluate to a sterile reaction vial.
 - Add the appropriate buffer to adjust the pH of the reaction mixture to between 4.0 and 5.0. For example, add 200 μL of 3 M ammonium acetate buffer (pH 4) or 1.5 mL of 2 M acetate buffer (pH 5.0).[1][6]
- Addition of the Precursor:
 - Add the **NODAGA-RGD** peptide to the buffered ^{68}Ga solution. The amount of precursor can vary, typically ranging from 10 to 50 μg . [6] For instance, one protocol uses 20 μg of **NODAGA-RGD**. [6]
- Incubation:
 - Heat the reaction mixture. Incubation temperatures and times can be optimized, with common conditions being 95°C for 10-15 minutes or 40°C for approximately 10 minutes. [1][6][7] Some studies have shown that labeling can also be achieved at room temperature within 5-10 minutes. [3][4]
- Purification of ^{68}Ga -**NODAGA-RGD**:
 - Pre-condition a C18 SPE cartridge by washing it with ethanol (e.g., 5 mL) followed by sterile water (e.g., 10 mL).
 - Pass the reaction mixture through the pre-conditioned C18 cartridge. The ^{68}Ga -**NODAGA-RGD** will be retained on the cartridge, while unreacted ^{68}Ga and other hydrophilic impurities will pass through.
 - Wash the cartridge with sterile water (e.g., 1 mL) to remove any remaining impurities.

- Elute the purified ^{68}Ga -**NODAGA-RGD** from the cartridge with a small volume of 50% ethanol (e.g., 2 x 250 μL or 1 mL).[1][6]
- Formulation:
 - The eluted ^{68}Ga -**NODAGA-RGD** solution is then typically diluted with sterile saline to obtain an injectable solution with a maximum of 10% ethanol.[6]
 - Pass the final product through a 0.22 μm sterile filter into a sterile vial.

Quality Control

Quality control is essential to ensure the purity and identity of the final radiopharmaceutical product.

- Radiochemical Purity (RCP):
 - Radio-TLC: RCP can be determined using radio-TLC with a mobile phase of 1 M ammonium acetate:methanol (1:1 v/v) on silica gel plates.[6]
 - Radio-HPLC: A more quantitative analysis is performed using a reversed-phase radio-HPLC system. A common method uses a C18 column with a gradient of acetonitrile and water containing 0.1% trifluoroacetic acid.[6] The radiochemical purity should typically be greater than 95%.[1]
- Other Quality Control Parameters: Additional tests should be performed according to pharmacopeial standards, including sterility, endotoxin levels, pH, and radionuclide identity. [6]

Data Presentation

The following tables summarize key quantitative data from various studies on ^{68}Ga -**NODAGA-RGD**.

Table 1: Radiolabeling and Quality Control Parameters

Parameter	Value	Reference
Radiochemical Yield	>95%	[1]
Radiochemical Purity	>99%	[1][6]
Specific Activity	12 - 24 MBq/nmol	[6]
Routinely ca. 500 GBq/μmol	[5]	
Synthesis Time	~15 minutes (automated)	[5]
~60 minutes (including QC)	[6]	
pH of final product	Within specified limits	[6]
Endotoxin amount	Within specified limits	[6]
⁶⁸ Ge-content	Within specified limits	[6]
Ethanol content	max. 10%	[6]

Table 2: In Vitro and In Vivo Performance

Parameter	Value	Reference
IC ₅₀ (αvβ3 binding affinity)	4.7 ± 1.6 nM	[4]
LogP (Hydrophilicity)	-4.0	[5]
-3.27 ± 0.01	[3]	
In vitro stability in human serum	Stable for at least 2 hours	[7]
Tumor-to-Blood Ratio (60 min p.i.)	11	[4]
Elimination Route	Predominantly renal	[6]
Effective Dose	21.5 ± 5.4 μSv/MBq	[6]

Visualization of Workflow and Signaling Pathway

Experimental Workflow

The following diagram illustrates the key steps in the manual radiolabeling of **NODAGA-RGD** with ^{68}Ga .

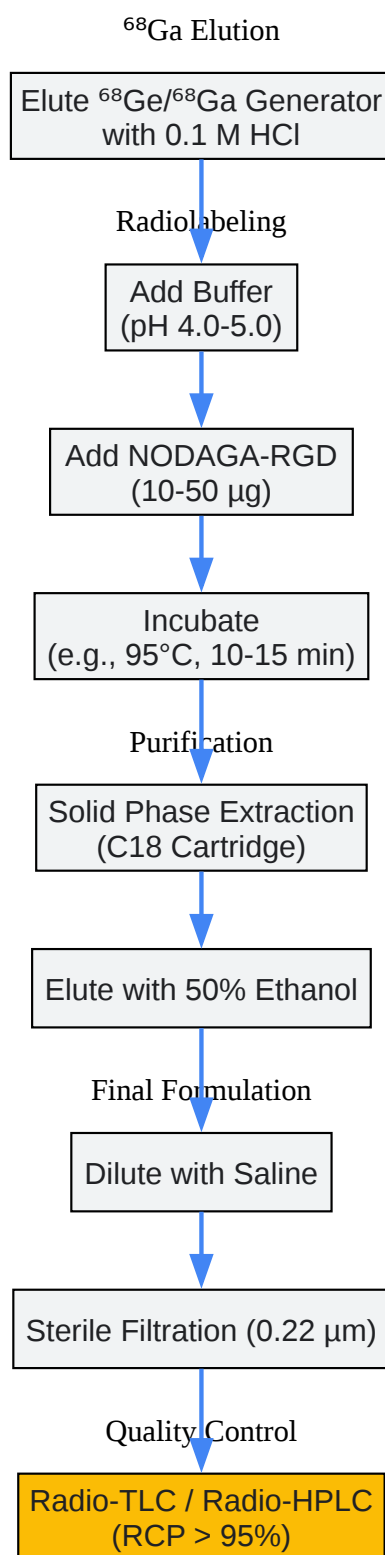

[Click to download full resolution via product page](#)

Caption: Workflow for ⁶⁸Ga-NODAGA-RGD Radiolabeling.

$\alpha v \beta 3$ Integrin Signaling Pathway

^{68}Ga -**NODAGA-RGD** targets the $\alpha v \beta 3$ integrin, which upon binding to its ligands in the extracellular matrix (ECM), initiates a cascade of intracellular signals crucial for cell survival, proliferation, migration, and angiogenesis.

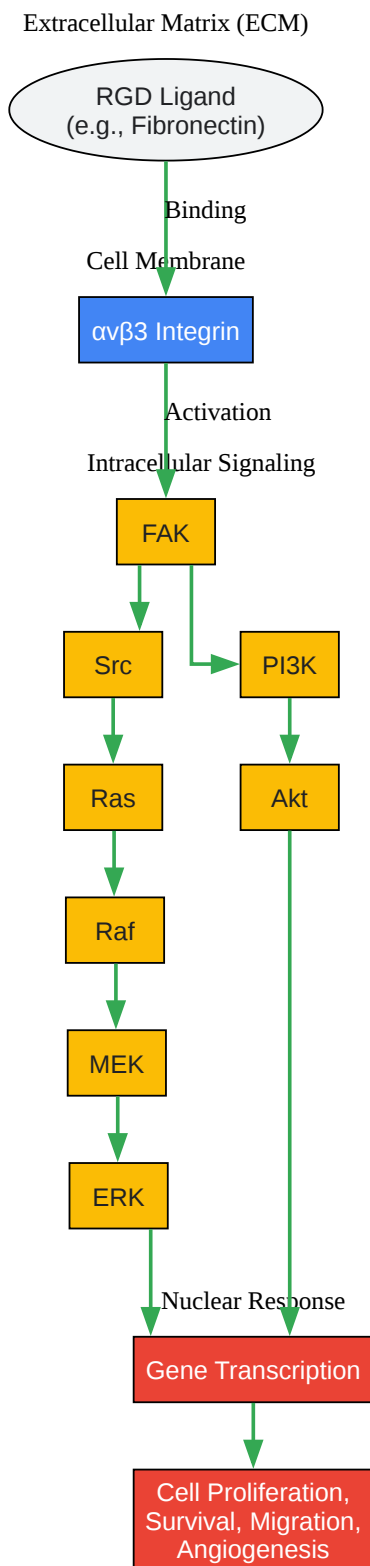

[Click to download full resolution via product page](#)

Caption: Simplified $\alpha\beta_3$ Integrin Signaling Pathway.

Need Custom Synthesis?

BenchChem offers custom synthesis for rare earth carbides and specific isotopic labeling.

Email: info@benchchem.com or [Request Quote Online](#).

References

- 1. Synthesis of Novel, Dual-Targeting ⁶⁸Ga-NODAGA-LacN-E[c(RGDfK)]₂ Glycopeptide as a PET Imaging Agent for Cancer Diagnosis - PMC [[pmc.ncbi.nlm.nih.gov](https://pubmed.ncbi.nlm.nih.gov)]
- 2. Integrins in Tumor Angiogenesis & Lymphangiogenesis - PMC [[pmc.ncbi.nlm.nih.gov](https://pubmed.ncbi.nlm.nih.gov)]
- 3. jnm.snmjournals.org [jnm.snmjournals.org]
- 4. [⁶⁸Ga]NODAGA-RGD for imaging αβ₃ integrin expression - PubMed [pubmed.ncbi.nlm.nih.gov]
- 5. ⁶⁸Ga-NODAGA-RGD is a suitable substitute for (18)F-Galacto-RGD and can be produced with high specific activity in a cGMP/GRP compliant automated process - PubMed [pubmed.ncbi.nlm.nih.gov]
- 6. [⁶⁸Ga]NODAGA-RGD – Metabolic stability, biodistribution, and dosimetry data from patients with hepatocellular carcinoma and liver cirrhosis - PMC [[pmc.ncbi.nlm.nih.gov](https://pubmed.ncbi.nlm.nih.gov)]
- 7. Human Dose Assessment of ⁶⁸Ga-NODAGA-RGD-BBN Heterodimer Peptide based on Animal Data - PMC [[pmc.ncbi.nlm.nih.gov](https://pubmed.ncbi.nlm.nih.gov)]
- To cite this document: BenchChem. [Application Notes and Protocols for Step-by-Step NODAGA-RGD Radiolabeling]. BenchChem, [2026]. [Online PDF]. Available at: [<https://www.benchchem.com/product/b15597843/docs#application-notes-and-protocols-for-step-by-step-nodaga-rgd-radiolabeling>]

Disclaimer & Data Validity:

The information provided in this document is for Research Use Only (RUO) and is strictly not intended for diagnostic or therapeutic procedures. While BenchChem strives to provide accurate protocols, we make no warranties, express or implied, regarding the fitness of this product for every specific experimental setup.

Technical Support: The protocols provided are for reference purposes. Unsure if this reagent suits your experiment?

Need Industrial/Bulk Grade? [Request Custom Synthesis Quote](#)

BenchChem

Our mission is to be the trusted global source of essential and advanced chemicals, empowering scientists and researchers to drive progress in science and industry.

Contact

Address: 3281 E Guasti Rd
Ontario, CA 91761, United States
Phone: (601) 213-4426
Email: info@benchchem.com

[Contact our Ph.D. Support Team for a compatibility check](#)