

# Lignin's Architectural Diversity: A Comparative Analysis Across Plant Species Using Model Compounds

**Author:** BenchChem Technical Support Team. **Date:** April 2026

## Compound of Interest

Compound Name: *Threo-guaiacylglycerol*

Cat. No.: B15594420

[Get Quote](#)

A comprehensive guide for researchers, scientists, and drug development professionals on the structural variations of lignin in softwood, hardwood, and grass species, featuring comparative data, detailed experimental protocols, and the application of model compounds for analysis.

Lignin, the second most abundant terrestrial biopolymer after cellulose, provides structural integrity to plant cell walls. Its complex and irregular structure, arising from the polymerization of phenylpropanoid precursors, varies significantly across different plant species.

Understanding these structural nuances is paramount for applications ranging from biofuel production to the development of novel biomaterials and pharmaceuticals. This guide provides a comparative analysis of lignin structure in softwoods, hardwoods, and grasses, supported by quantitative data, detailed experimental protocols for key analytical techniques, and the use of model compounds to elucidate specific structural motifs.

## Comparative Analysis of Lignin Composition and Linkages

The fundamental building blocks of lignin are the monolignols: p-coumaryl alcohol, coniferyl alcohol, and sinapyl alcohol, which give rise to p-hydroxyphenyl (H), guaiacyl (G), and syringyl (S) units, respectively, within the lignin polymer. The relative abundance of these units and the types of chemical bonds that link them define the lignin's overall structure and properties.

Softwood lignins, found in gymnosperms like pine and spruce, are primarily composed of G units with a low proportion of H units.[1][2] Hardwood lignins, from angiosperms such as birch and poplar, are characterized by a higher proportion of S and G units.[2][3] Grass lignins, from plants like wheat straw, contain a mixture of G and S units and a higher proportion of H units compared to wood lignins.[4] The variation in monomeric composition directly influences the frequency of different inter-unit linkages. For instance, the higher S-unit content in hardwoods leads to a greater proportion of the more easily cleavable  $\beta$ -O-4 ether linkages.[5][6]

Table 1: Monomeric Composition (S/G/H Ratio) of Lignin in Different Plant Species

Plant Type	Species	S/G Ratio	H:G:S Ratio (%)	Reference
Softwood	Pine (Pinus sp.)	~0.02	4:94:2	[1]
	Spruce (Picea sp.)	~0.01	5:94:1	[1]
Hardwood	Birch (Betula sp.)	~2.0	4:48:48	[1]
	Poplar (Populus sp.)	~2.0	4:48:48	[7]
	Sugar Maple (Acer saccharum)	~1.4	-	[7]
Grass	Wheat Straw	~0.6-0.9	6:54:40	[4]

Table 2: Relative Abundance of Major Inter-unit Linkages in Lignin (% of Total Linkages)

Linkage Type	Softwood	Hardwood	Grass	Reference
$\beta$ -O-4 (Aryl ether)	43-50	50-65	50-60	[5][6]
$\beta$ -5 (Phenylcoumaran)	9-12	6	5-7	[8][9]
5-5 (Biphenyl)	18-25	9-14	10-15	[8][9]
$\beta$ - $\beta$ (Resinol)	2	3	4-5	[8][9]
4-O-5	4	6-7	5-6	[8][9]
$\beta$ -1	3-7	5-7	6-8	[8][9]

## The Role of Model Compounds in Lignin Analysis

The complexity of the lignin polymer makes its direct analysis challenging. Lignin model compounds, which are synthetic molecules representing specific structural units and linkages found in native lignin, are invaluable tools for understanding lignin chemistry.[10] By studying the behavior of these simpler molecules under various analytical conditions, researchers can develop and validate methods for characterizing the more complex native lignin. For instance, synthetic  $\beta$ -O-4 dimers can be used to optimize NMR and mass spectrometry techniques for quantifying this crucial linkage in different lignin samples.[11][12][13] Similarly, model compounds for  $\beta$ - $\beta$  (resinol) and 5-5 (biphenyl) linkages aid in the unequivocal identification of these more condensed structures.[14][15]

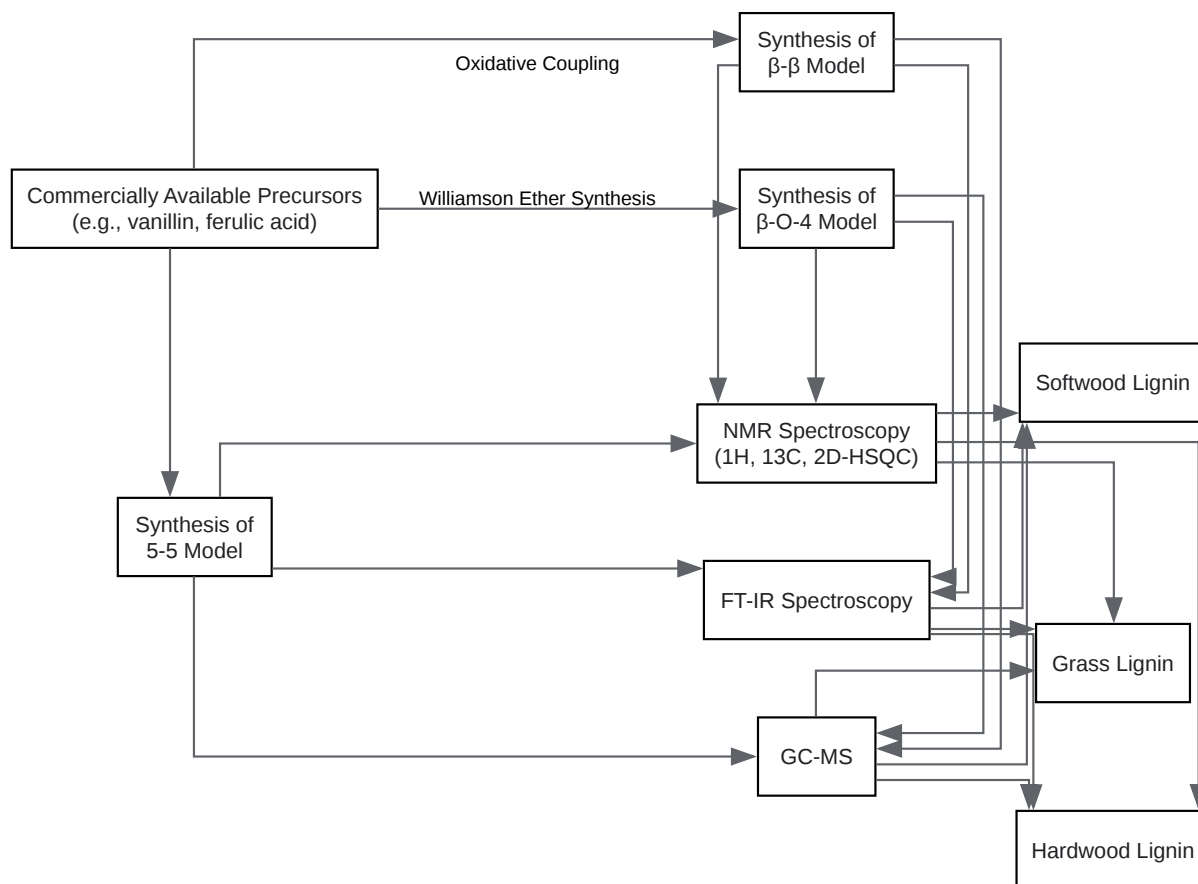

[Click to download full resolution via product page](#)

Caption: Workflow for the use of lignin model compounds in comparative analysis.

## Experimental Protocols

Accurate and reproducible analysis of lignin structure is fundamental to comparative studies. The following sections provide detailed methodologies for three key analytical techniques.

### 2D Heteronuclear Single Quantum Coherence (HSQC) NMR Spectroscopy

2D HSQC NMR is a powerful non-destructive technique that provides detailed information about the various C-H correlations in lignin, allowing for the identification and semi-quantitative

analysis of monolignol units and inter-unit linkages.[16][17]

#### Sample Preparation:

- Dry approximately 50-80 mg of the isolated lignin sample in a vacuum oven at 40°C overnight.[18]
- Dissolve the dried lignin in 0.55 mL of deuterated dimethyl sulfoxide (DMSO-d6).[19]
- Transfer the solution to a 5 mm NMR tube.

#### NMR Acquisition:

- Acquire 2D HSQC spectra on a Bruker AVANCE spectrometer (or equivalent) equipped with a cryoprobe.
- Set the spectral widths to appropriate values for the  $^1\text{H}$  (e.g., 10 ppm) and  $^{13}\text{C}$  (e.g., 160 ppm) dimensions.
- Use a standard HSQC pulse sequence (e.g., hsqcetgpsisp2.2).
- Acquire a sufficient number of scans (e.g., 128) and transients (e.g., 2048) to achieve a good signal-to-noise ratio.

#### Data Processing and Analysis:

- Process the acquired data using appropriate software (e.g., MestReNova, TopSpin).
- Apply a squared sine-bell window function in both dimensions.
- Perform baseline correction.
- Integrate the cross-peaks corresponding to specific lignin substructures (S, G, H units and various linkages) and normalize to a suitable internal standard or a specific lignin signal for semi-quantitative comparison.[16]

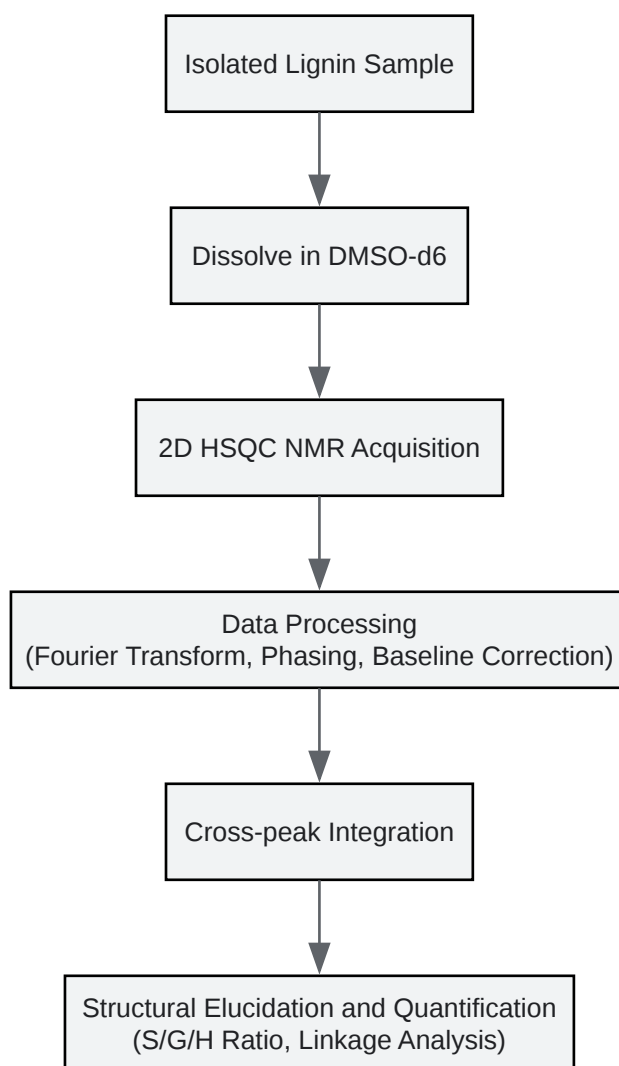

[Click to download full resolution via product page](#)

Caption: Experimental workflow for 2D HSQC NMR analysis of lignin.

## Gas Chromatography-Mass Spectrometry (GC-MS)

GC-MS is a destructive analytical technique used to identify and quantify the monomeric composition of lignin after chemical degradation. This is particularly useful for determining the S/G/H ratio.<sup>[20][21]</sup>

Sample Preparation and Derivatization:

- Accurately weigh approximately 1-2 mg of the extractive-free, dried biomass sample into a reaction vial.

- Perform a chemical degradation method such as thioacidolysis to cleave the ether linkages in the lignin.
- Evaporate the reaction mixture to dryness under a stream of nitrogen.
- Derivatize the resulting monomers by adding a mixture of pyridine and N,O-bis(trimethylsilyl)trifluoroacetamide (BSTFA) with 1% trimethylchlorosilane (TMCS) and heating at 60°C for 30 minutes to convert hydroxyl groups to their trimethylsilyl (TMS) ethers. [\[20\]](#)

#### GC-MS Analysis:

- Inject an aliquot of the derivatized sample into a gas chromatograph coupled to a mass spectrometer.
- Use a capillary column suitable for separating the TMS-derivatized lignin monomers (e.g., DB-5ms).
- Employ a temperature program that allows for the separation of the different monomers (e.g., initial temperature of 100°C, ramp to 300°C).
- Operate the mass spectrometer in electron ionization (EI) mode and scan a mass range of m/z 50-650.

#### Data Analysis:

- Identify the lignin monomers by comparing their retention times and mass spectra with those of authentic standards and library data.
- Quantify the monomers by integrating the peak areas and using a response factor determined from the analysis of standard compounds.

## Fourier-Transform Infrared (FT-IR) Spectroscopy

FT-IR spectroscopy is a rapid and non-destructive technique that provides information about the functional groups present in lignin. It can be used for qualitative comparisons and, with calibration, for quantitative analysis. [\[22\]](#)[\[23\]](#)

### Sample Preparation:

- For solid-state analysis, prepare a KBr pellet by mixing approximately 1 mg of finely ground, dried lignin with 100-200 mg of spectroscopic grade KBr and pressing the mixture into a transparent disk.[\[22\]](#)
- Alternatively, for Attenuated Total Reflectance (ATR)-FTIR, place a small amount of the powdered lignin sample directly onto the ATR crystal.[\[23\]](#)

### FT-IR Analysis:

- Record the FT-IR spectrum over a range of 4000 to 400  $\text{cm}^{-1}$ .
- Collect a sufficient number of scans (e.g., 32 or 64) to obtain a good signal-to-noise ratio.
- Perform a background scan before analyzing the sample.

### Data Analysis:

- Identify the characteristic absorption bands corresponding to different functional groups in lignin (e.g., O-H stretching, C-H stretching, aromatic skeletal vibrations, C=O stretching).
- Compare the spectra of different lignin samples to identify qualitative differences in their functional group composition.
- For semi-quantitative analysis, the intensity of specific bands can be normalized to a reference band that is assumed to be constant across samples.

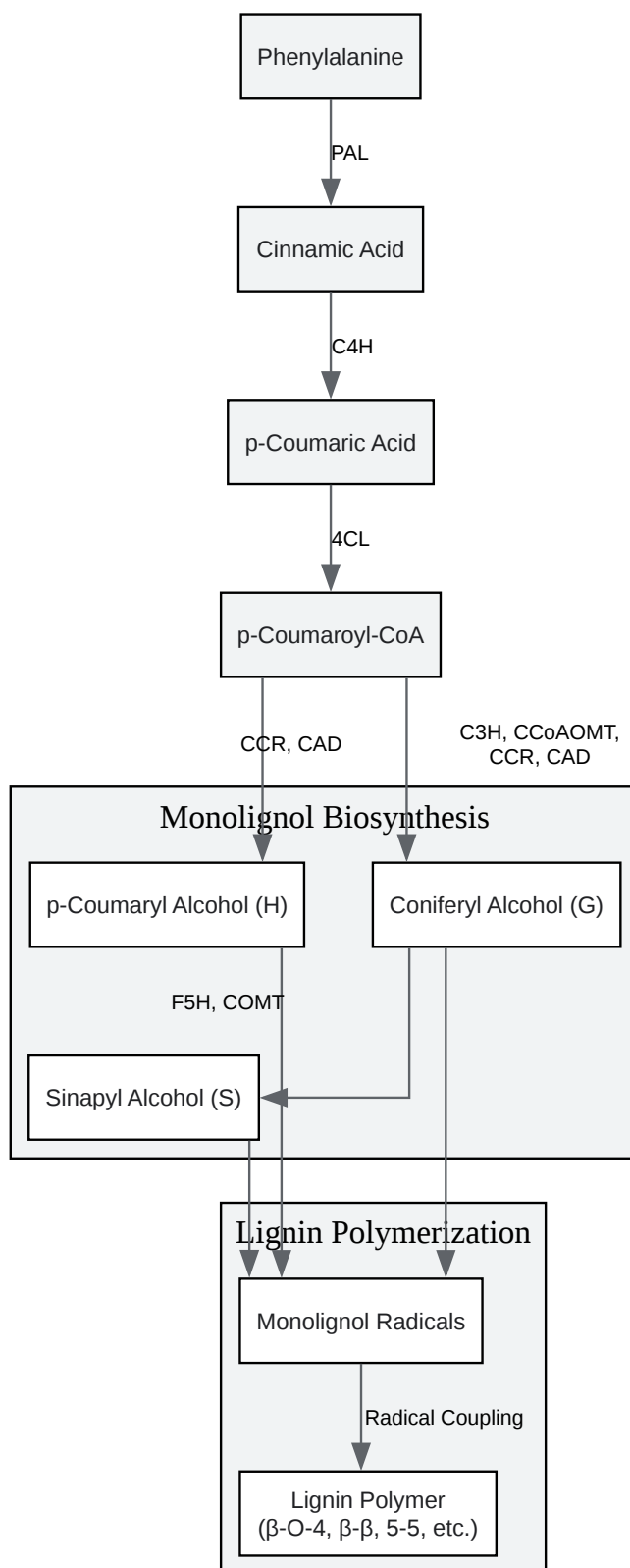

[Click to download full resolution via product page](#)

Caption: Simplified monolignol biosynthetic pathway.

This guide provides a foundational framework for the comparative analysis of lignin structure. By employing the described analytical techniques and leveraging the insights gained from model compound studies, researchers can further unravel the complexities of this fascinating biopolymer and unlock its full potential in various scientific and industrial applications.

### *Need Custom Synthesis?*

*BenchChem offers custom synthesis for rare earth carbides and specific isotopic labeling.*

*Email: [info@benchchem.com](mailto:info@benchchem.com) or [Request Quote Online](#).*

## References

- [1. Analysis of Lignin S/G Ratio, Lignin S/G Ratio Content of Biomass - Celignis Biomass Analysis Laboratory \[celignis.com\]](#)
- [2. researchgate.net \[researchgate.net\]](#)
- [3. The effects of lignin source and extraction on the composition and properties of biorefined depolymerization products - RSC Sustainability \(RSC Publishing\) DOI:10.1039/D3SU00262D \[pubs.rsc.org\]](#)
- [4. researchgate.net \[researchgate.net\]](#)
- [5. researchgate.net \[researchgate.net\]](#)
- [6. researchgate.net \[researchgate.net\]](#)
- [7. researchgate.net \[researchgate.net\]](#)
- [8. researchgate.net \[researchgate.net\]](#)
- [9. researchgate.net \[researchgate.net\]](#)
- [10. researchgate.net \[researchgate.net\]](#)
- [11. Synthesis of  \$\beta\$ -O-4-type artificial lignin polymers and their analysis by NMR spectroscopy - Organic & Biomolecular Chemistry \(RSC Publishing\) \[pubs.rsc.org\]](#)
- [12. Chemical synthesis of  \$\beta\$ -O-4 type artificial lignin - Organic & Biomolecular Chemistry \(RSC Publishing\) \[pubs.rsc.org\]](#)
- [13. researchgate.net \[researchgate.net\]](#)
- [14. Synthesis and characterization of new 5-linked pinoresinol lignin models - PubMed \[pubmed.ncbi.nlm.nih.gov\]](#)

- [15. tandfonline.com \[tandfonline.com\]](https://tandfonline.com)
- [16. researchgate.net \[researchgate.net\]](https://researchgate.net)
- [17. pubs.acs.org \[pubs.acs.org\]](https://pubs.acs.org)
- [18. google.com \[google.com\]](https://google.com)
- [19. mdpi.com \[mdpi.com\]](https://mdpi.com)
- [20. researchgate.net \[researchgate.net\]](https://researchgate.net)
- [21. pubs.rsc.org \[pubs.rsc.org\]](https://pubs.rsc.org)
- [22. researchgate.net \[researchgate.net\]](https://researchgate.net)
- [23. Characterization of organosolv lignins using thermal and FT-IR spectroscopic analysis :: BioResources \[bioresources.cnr.ncsu.edu\]](#)
- To cite this document: BenchChem. [Lignin's Architectural Diversity: A Comparative Analysis Across Plant Species Using Model Compounds]. BenchChem, [2026]. [Online PDF]. Available at: [<https://www.benchchem.com/product/b15594420/docs#lignin-s-architectural-diversity-a-comparative-analysis-across-plant-species-using-model-compounds>]

---

#### Disclaimer & Data Validity:

The information provided in this document is for Research Use Only (RUO) and is strictly not intended for diagnostic or therapeutic procedures. While BenchChem strives to provide accurate protocols, we make no warranties, express or implied, regarding the fitness of this product for every specific experimental setup.

**Technical Support:** The protocols provided are for reference purposes. Unsure if this reagent suits your experiment?

**Need Industrial/Bulk Grade?** [Request Custom Synthesis Quote](#)

# BenchChem

Our mission is to be the trusted global source of essential and advanced chemicals, empowering scientists and researchers to drive progress in science and industry.

## Contact

Address: 3281 E Guasti Rd

Ontario, CA 91761, United States

Phone: (601) 213-4426

Email: [info@benchchem.com](mailto:info@benchchem.com)

[Contact our Ph.D. Support Team for a compatibility check](#)