

Quercimeritrin (Quercetin 7-O- β -D-glucoside): An In-depth Technical Guide

Author: BenchChem Technical Support Team. **Date:** April 2026

Compound of Interest

Compound Name: Quercimeritrin (Standard)

Cat. No.: B15592757

[Get Quote](#)

For Researchers, Scientists, and Drug Development Professionals

Abstract

Quercimeritrin, a flavonoid glycoside, is a naturally occurring compound found in various plant species. As a quercetin 7-O- β -D-glucoside, its biological activities are intrinsically linked to its aglycone, quercetin, a well-researched flavonol with potent antioxidant and anti-inflammatory properties. This technical guide provides a comprehensive overview of Quercimeritrin, including its chemical and physical properties, biosynthesis, and known biological activities with a focus on quantitative data where available. Detailed experimental protocols for the isolation, purification, and analysis of Quercimeritrin and related compounds are provided to facilitate further research. Additionally, key signaling pathways influenced by its aglycone, quercetin, are illustrated to provide insights into its potential mechanisms of action. This document aims to serve as a valuable resource for researchers and professionals in the fields of pharmacology, natural product chemistry, and drug development.

Chemical and Physical Properties

Quercimeritrin is chemically known as 2-(3,4-dihydroxyphenyl)-3,5-dihydroxy-7-[(2S,3R,4S,5S,6R)-3,4,5-trihydroxy-6-(hydroxymethyl)oxan-2-yl]oxychromen-4-one. Its key

properties are summarized in the table below.

Property	Value	Reference(s)
Molecular Formula	C ₂₁ H ₂₀ O ₁₂	[1]
Molecular Weight	464.38 g/mol	[1]
CAS Number	491-50-9	[1]
Appearance	Yellow crystalline solid	
Solubility	Soluble in DMSO and DMF	
Synonyms	Quercetin 7-O-beta-D-glucoside, Quercimeritroside	[1]

Biosynthesis

The biosynthesis of Quercimeritrin involves the glycosylation of the flavonoid aglycone, quercetin. This reaction is catalyzed by a specific UDP-dependent glycosyltransferase (UGT), namely a flavonol 7-O-glucosyltransferase. This enzyme facilitates the transfer of a glucose moiety from UDP-glucose to the 7-hydroxyl group of quercetin.

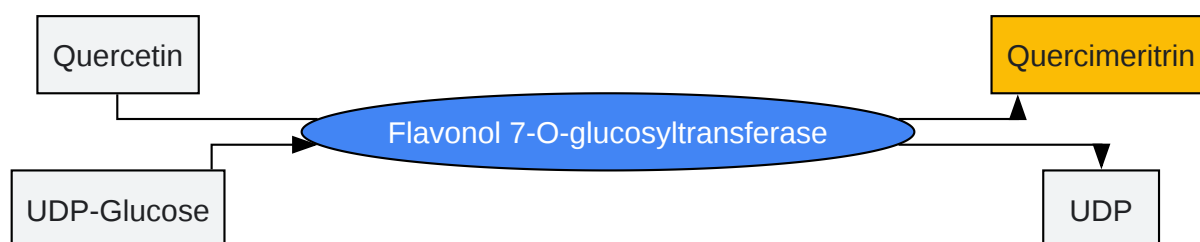

[Click to download full resolution via product page](#)

Biosynthesis of Quercimeritrin from Quercetin.

Biological Activity and Quantitative Data

While specific quantitative data for Quercimeritrin is limited, the biological activities of its aglycone, quercetin, and closely related glycosides provide valuable insights into its potential

therapeutic effects.

Antioxidant Activity

Quercetin is a potent antioxidant. The antioxidant activities of quercetin and its related glycosides are often evaluated using assays such as DPPH (2,2-diphenyl-1-picrylhydrazyl) and ABTS (2,2'-azino-bis(3-ethylbenzothiazoline-6-sulfonic acid)) radical scavenging assays.

Compound	Assay	IC ₅₀ (μM)	Reference(s)
Quercetin	DPPH	~5.8 - 19.17 μg/mL	[2][3]
Quercetin	ABTS	1.89 μg/mL	[4]
Quercitrin	DPPH	87.99 ± 5.43	[5]
Isoquercitrin	DPPH	78.16 ± 4.83	[5]

Anti-inflammatory Activity

Quercetin and its glycosides have demonstrated significant anti-inflammatory properties, often attributed to their ability to inhibit key inflammatory enzymes and signaling pathways.

Compound	Assay	IC ₅₀ (μM)	Reference(s)
Quercetin	Lipoxygenase (LOX)	0.7	[6]
Quercetin	Cyclooxygenase (COX)	-	
Quercimeritrin	α-Glucosidase	79.88	

Note: Specific IC₅₀ values for COX inhibition by Quercimeritrin were not found in the literature. In vivo studies on the related compound quercitrin suggest its anti-inflammatory effects are mediated by the release of quercetin, which then inhibits the NF-κB pathway[7].

Signaling Pathways

The biological effects of Quercimeritrin are largely attributed to the activity of its aglycone, quercetin, which is known to modulate several key signaling pathways involved in inflammation and cellular stress responses.

NF- κ B Signaling Pathway

Quercetin has been shown to inhibit the NF- κ B (Nuclear Factor kappa-light-chain-enhancer of activated B cells) signaling pathway, a critical regulator of the inflammatory response. Inhibition of this pathway leads to a reduction in the expression of pro-inflammatory cytokines and enzymes.

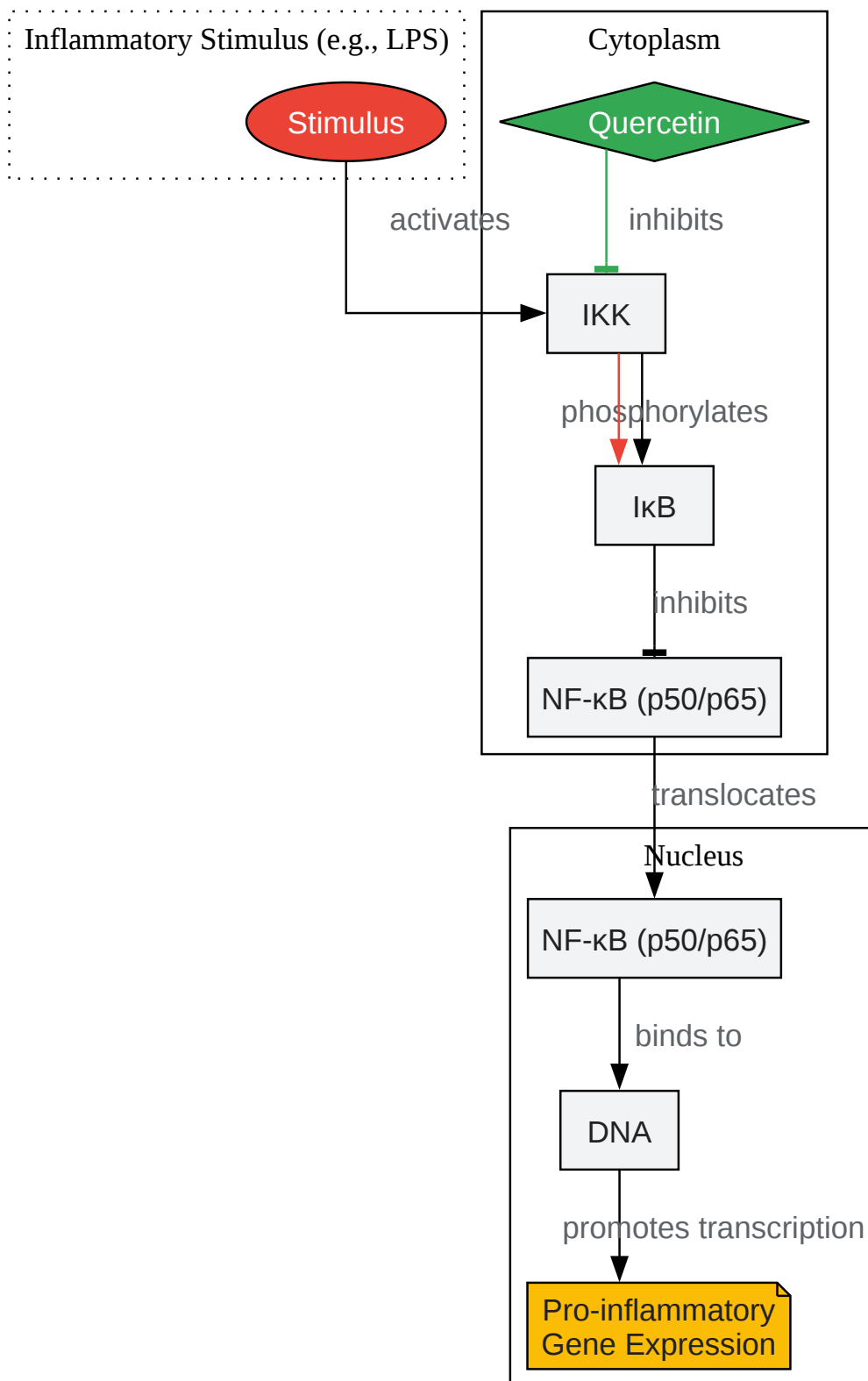

[Click to download full resolution via product page](#)

Inhibition of the NF-κB signaling pathway by Quercetin.

MAPK Signaling Pathway

Quercetin also modulates the Mitogen-Activated Protein Kinase (MAPK) signaling pathway, which is involved in cellular processes such as proliferation, differentiation, and apoptosis, as well as the inflammatory response. Quercetin can inhibit the phosphorylation of key MAPK proteins like ERK, JNK, and p38.

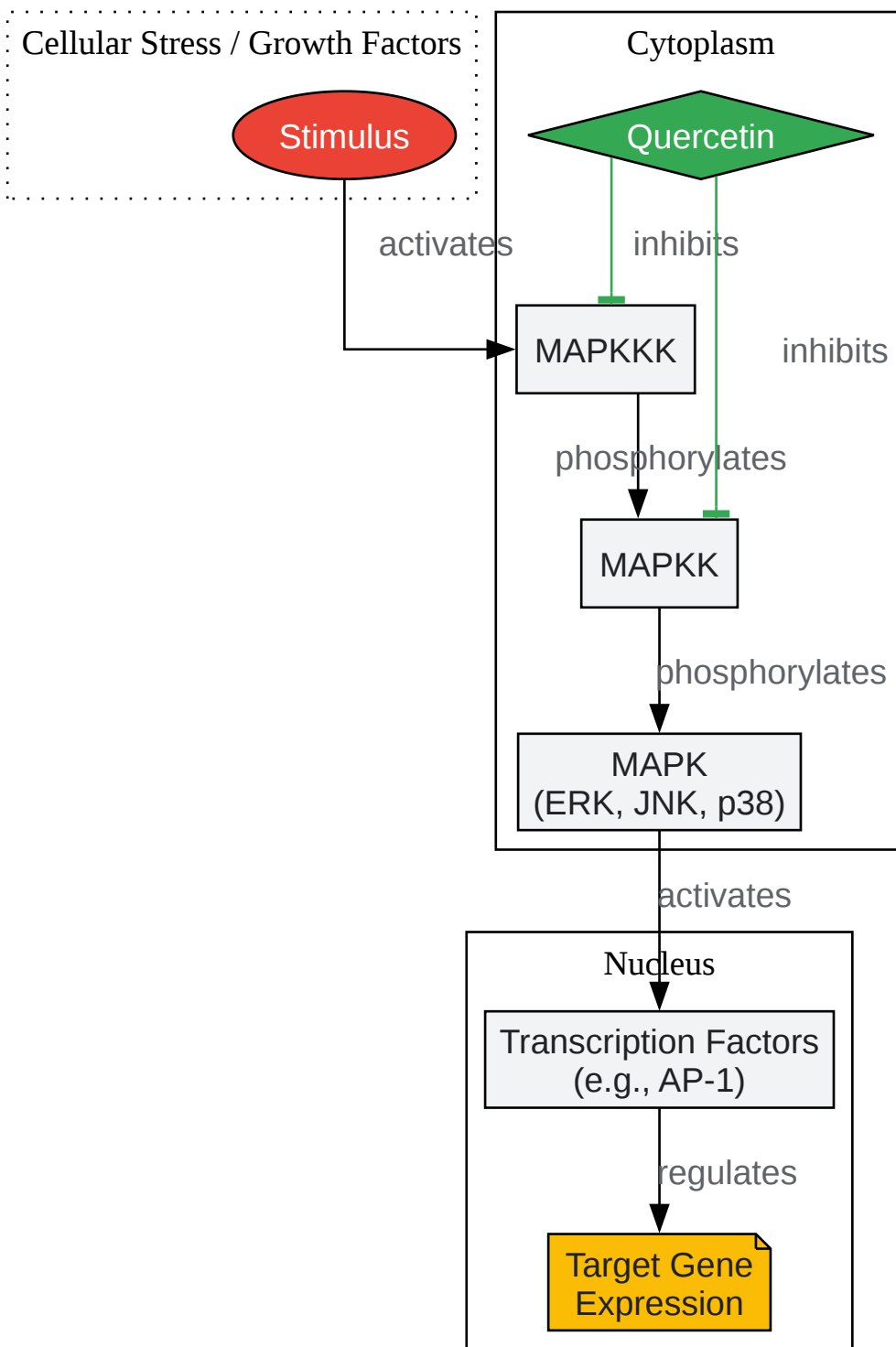

[Click to download full resolution via product page](#)

Modulation of the MAPK signaling pathway by Quercetin.

Experimental Protocols

Isolation and Purification of Quercimeritrin

This protocol describes a general method for the isolation and purification of Quercimeritrin from plant material, such as cotton flowers (*Gossypium herbaceum*), where it is naturally found.

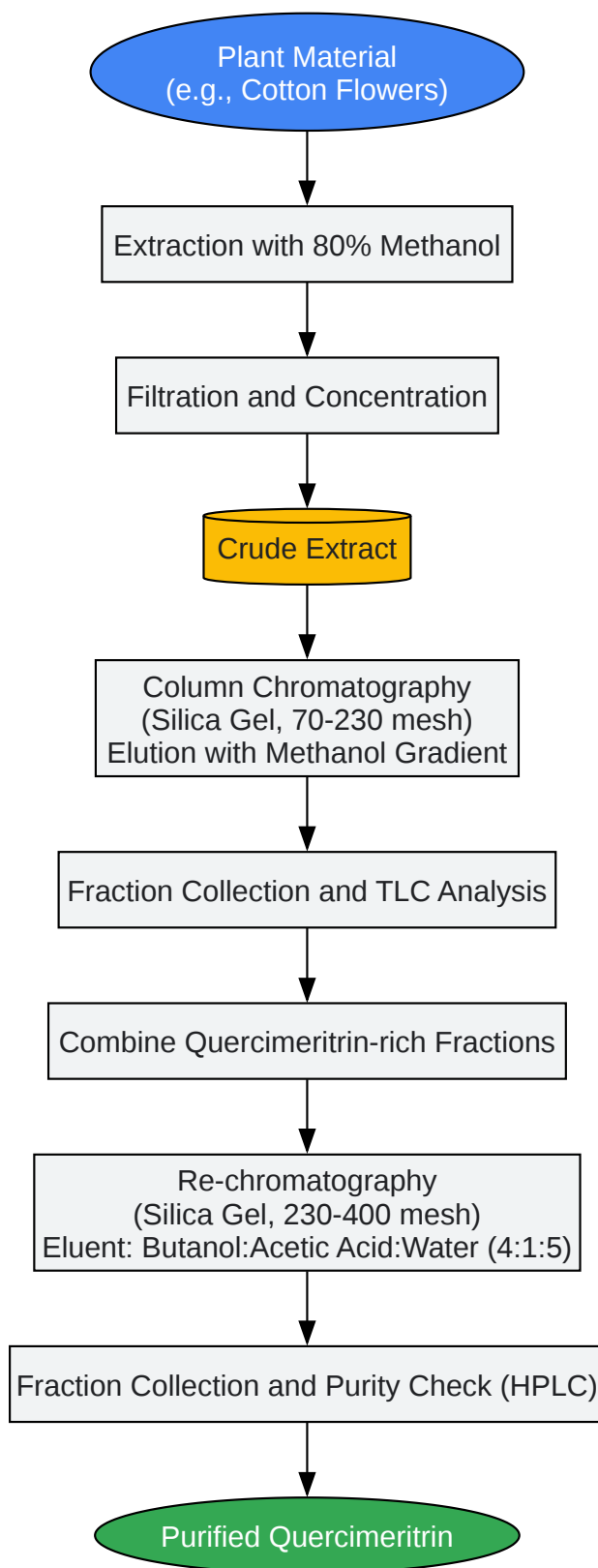

[Click to download full resolution via product page](#)

Workflow for the isolation and purification of Quercimeritrin.

Methodology:

- **Extraction:** Air-dried and powdered plant material is extracted with 80% methanol at room temperature with continuous stirring for 24 hours. The process is repeated three times.
- **Filtration and Concentration:** The extracts are combined, filtered, and concentrated under reduced pressure using a rotary evaporator to obtain a crude extract.
- **Column Chromatography (Step 1):** The crude extract is subjected to column chromatography on a silica gel column (70-230 mesh). Elution is performed with a gradient of methanol in chloroform.
- **Fraction Collection and Analysis:** Fractions are collected and monitored by Thin Layer Chromatography (TLC). Fractions showing a spot corresponding to a Quercimeritrin standard are pooled.
- **Re-chromatography (Step 2):** The pooled fractions are further purified by a second column chromatography on silica gel (230-400 mesh) using a solvent system of butanol:acetic acid:water (4:1:5, v/v/v).
- **Final Purification and Verification:** Fractions are collected and analyzed by High-Performance Liquid Chromatography (HPLC) for purity. Fractions containing pure Quercimeritrin are combined and the solvent is evaporated to yield the purified compound.

HPLC Quantification of Quercimeritrin

This protocol outlines a reversed-phase HPLC method for the quantification of Quercimeritrin in plant extracts or other matrices.

Chromatographic Conditions:

- **Column:** C18 column (e.g., 4.6 x 250 mm, 5 μ m)
- **Mobile Phase:** A gradient of acetonitrile (Solvent B) in water with 0.1% formic acid (Solvent A).
 - 0-5 min: 10% B

- 5-25 min: 10-40% B
- 25-30 min: 40-10% B
- Flow Rate: 1.0 mL/min
- Detection: UV detector at 257 nm and 372 nm
- Injection Volume: 20 μ L
- Column Temperature: 25 $^{\circ}$ C

Standard and Sample Preparation:

- Standard Solution: A stock solution of pure Quercimeritrin is prepared in methanol (e.g., 1 mg/mL) and serially diluted to create a calibration curve (e.g., 1, 5, 10, 25, 50, 100 μ g/mL).
- Sample Preparation: The extract is dissolved in methanol, filtered through a 0.45 μ m syringe filter, and diluted to an appropriate concentration to fall within the range of the calibration curve.

In Vitro Anti-inflammatory Assay: Inhibition of Nitric Oxide Production in RAW 264.7 Macrophages

This protocol describes an assay to evaluate the anti-inflammatory potential of Quercimeritrin by measuring its ability to inhibit nitric oxide (NO) production in lipopolysaccharide (LPS)-stimulated RAW 264.7 macrophage cells.

Methodology:

- Cell Culture: RAW 264.7 cells are cultured in DMEM supplemented with 10% FBS and 1% penicillin-streptomycin at 37 $^{\circ}$ C in a 5% CO₂ incubator.
- Cell Seeding: Cells are seeded in a 96-well plate at a density of 5 x 10⁴ cells/well and allowed to adhere overnight.
- Treatment: The culture medium is replaced with fresh medium containing various concentrations of Quercimeritrin (e.g., 1, 5, 10, 25, 50 μ M) and incubated for 1 hour.

- Stimulation: Cells are then stimulated with LPS (1 $\mu\text{g}/\text{mL}$) and incubated for 24 hours.
- Nitrite Measurement (Griess Assay):
 - 50 μL of the cell culture supernatant is mixed with 50 μL of Griess Reagent A (1% sulfanilamide in 5% phosphoric acid) and incubated for 10 minutes at room temperature in the dark.
 - 50 μL of Griess Reagent B (0.1% N-(1-naphthyl)ethylenediamine dihydrochloride in water) is added, and the mixture is incubated for another 10 minutes.
 - The absorbance is measured at 540 nm using a microplate reader.
- Calculation: The concentration of nitrite is determined from a sodium nitrite standard curve. The percentage of NO inhibition is calculated relative to the LPS-stimulated control.

Pharmacokinetics and Metabolism (ADME)

Specific ADME (Absorption, Distribution, Metabolism, and Excretion) data for Quercimeritrin is not extensively available. However, studies on quercetin and its other glycosides suggest that glycosylation significantly impacts bioavailability. Generally, quercetin glycosides are poorly absorbed in their intact form. They are often hydrolyzed by intestinal microflora or enzymes in the small intestine to the aglycone, quercetin, which is then absorbed.

Inference from Related Compounds:

- Absorption: The absorption of quercetin from its glycosides is generally higher than from the aglycone itself. The glucose moiety can facilitate transport across the intestinal epithelium.
- Metabolism: Once absorbed, quercetin undergoes extensive metabolism in the liver and other tissues, primarily through glucuronidation, sulfation, and methylation.
- Excretion: The metabolites are then excreted in the urine and bile.

Further studies, such as Caco-2 cell permeability assays and in vivo pharmacokinetic studies, are required to determine the specific ADME profile of Quercimeritrin.

Conclusion

Quercimeritrin, as a quercetin 7-O- β -D-glucoside, holds significant potential as a bioactive compound, largely owing to the well-documented antioxidant and anti-inflammatory properties of its aglycone, quercetin. While direct quantitative data on Quercimeritrin's biological activities are still emerging, the information available for closely related compounds provides a strong rationale for its further investigation. The experimental protocols and pathway diagrams provided in this guide are intended to facilitate and guide future research into the precise mechanisms of action and therapeutic potential of Quercimeritrin. As research progresses, a more detailed understanding of its pharmacokinetic profile and specific biological effects will be crucial for its development as a potential therapeutic agent or nutraceutical.

Need Custom Synthesis?

BenchChem offers custom synthesis for rare earth carbides and specific isotopic labeling.

Email: info@benchchem.com or [Request Quote Online](#).

References

- [1. Protocol Library | Collaborate and Share \[protocols.opentrons.com\]](#)
- [2. nehu.ac.in \[nehu.ac.in\]](#)
- [3. researchgate.net \[researchgate.net\]](#)
- [4. Antioxidant and Anti-Inflammatory Activity Determination of One Hundred Kinds of Pure Chemical Compounds Using Offline and Online Screening HPLC Assay - PMC \[pmc.ncbi.nlm.nih.gov\]](#)
- [5. Quercetin and Quercitrin Attenuates the Inflammatory Response and Oxidative Stress in LPS-Induced RAW264.7 Cells: In Vitro Assessment and a Theoretical Model - PMC \[pmc.ncbi.nlm.nih.gov\]](#)
- [6. researchgate.net \[researchgate.net\]](#)
- [7. In vivo quercitrin anti-inflammatory effect involves release of quercetin, which inhibits inflammation through down-regulation of the NF-kappaB pathway - PubMed \[pubmed.ncbi.nlm.nih.gov\]](#)
- To cite this document: BenchChem. [Quercimeritrin (Quercetin 7-O- β -D-glucoside): An In-depth Technical Guide]. BenchChem, [2026]. [Online PDF]. Available at:

[<https://www.benchchem.com/product/b15592757/docs#quercimeritrin-quercetin-7-o-d-glucoside-an-in-depth-technical-guide>]

Disclaimer & Data Validity:

The information provided in this document is for Research Use Only (RUO) and is strictly not intended for diagnostic or therapeutic procedures. While BenchChem strives to provide accurate protocols, we make no warranties, express or implied, regarding the fitness of this product for every specific experimental setup.

Technical Support: The protocols provided are for reference purposes. Unsure if this reagent suits your experiment?

Need Industrial/Bulk Grade? [Request Custom Synthesis Quote](#)

BenchChem

Our mission is to be the trusted global source of essential and advanced chemicals, empowering scientists and researchers to drive progress in science and industry.

Contact

Address: 3281 E Guasti Rd
Ontario, CA 91761, United States
Phone: (601) 213-4426
Email: info@benchchem.com

[Contact our Ph.D. Support Team for a compatibility check](#)