

# Application Notes and Protocols for a Cellular Analysis of Momordicoside X

**Author:** BenchChem Technical Support Team. **Date:** December 2025

## Compound of Interest

Compound Name: *Momordicoside X*

Cat. No.: *B15592252*

[Get Quote](#)

For Researchers, Scientists, and Drug Development Professionals

These application notes provide a comprehensive guide for investigating the biological activities of **Momordicoside X**, a cucurbitane-type triterpenoid glycoside isolated from *Momordica charantia* (bitter melon). While specific experimental data for **Momordicoside X** is limited, the protocols outlined below are based on established methodologies for closely related compounds, such as Momordicoside K and Momordicine I, which are expected to share similar biological activities. The primary activities of these related compounds are centered on metabolic regulation, anti-inflammatory effects, and anticancer properties, often mediated through the activation of the AMP-activated protein kinase (AMPK) signaling pathway.

## Data Presentation

The following tables summarize quantitative data for structurally related momordicosides to serve as a reference for experimental design and data interpretation when testing **Momordicoside X**.

Table 1: Cytotoxicity of Momordicine I in Human Head and Neck Cancer (HNC) Cell Lines

Cell Line	IC50 (µg/mL) after 48h
Cal27	7.0[1]
JHU029	6.5[1]
JHU022	17.0[1]

Table 2: Effect of Momordicine I on Cardiomyocyte Viability

Concentration (µg/mL)	Cell Viability (% of Control)
1.625 - 12.5	No significant difference[1]
25.0	Significant decrease[1]

Table 3: Anti-inflammatory Effects of Cucurbitane-type Triterpenoids

Compound	Assay	Cell Line	IC50 (µM)
Kuguaovins A–G (1–7)	Anti-NO Production	Not Specified	15–35[2]
Known Cucurbitanes (9–12)	Anti-NO Production	Not Specified	15–35[2]

## Key Signaling Pathways

Momordicosides primarily exert their effects by modulating key cellular signaling pathways involved in metabolism, inflammation, and cell survival.

### AMP-Activated Protein Kinase (AMPK) Pathway

AMPK is a crucial sensor of cellular energy status. Activation of AMPK by momordicosides can lead to:

- Increased glucose uptake in muscle and fat cells.[3]
- Enhanced fatty acid oxidation.[3][4]

- Inhibition of fatty acid synthesis.[3]

This pathway is a primary target for investigating the potential anti-diabetic effects of **Momordicoside X**. [3][4]

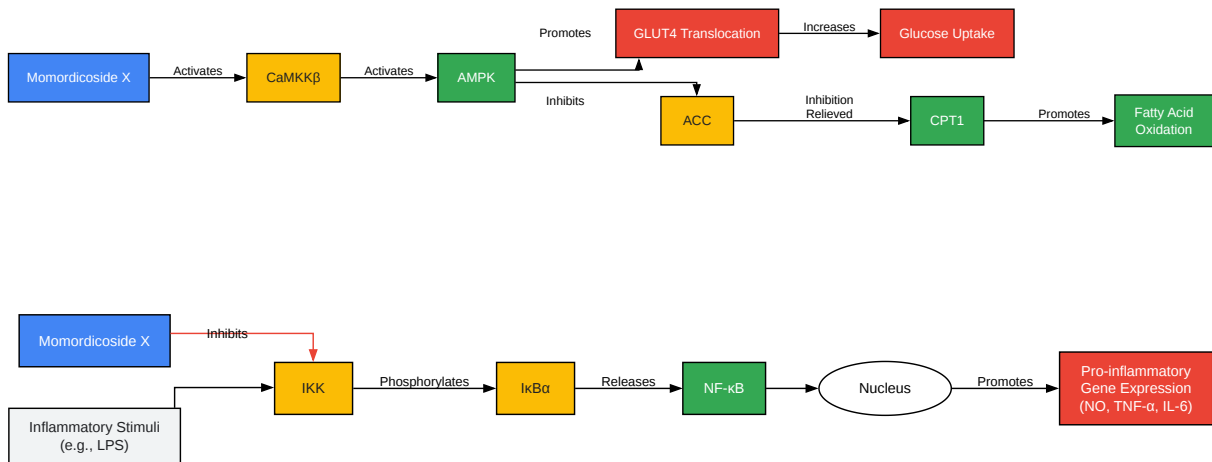

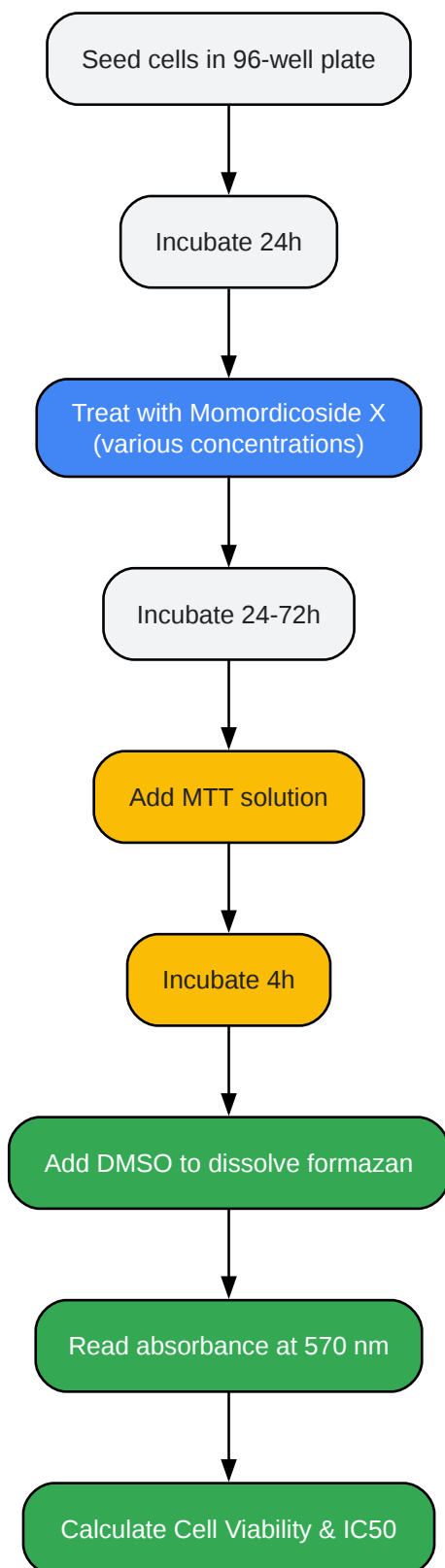

[Click to download full resolution via product page](#)

### Need Custom Synthesis?

BenchChem offers custom synthesis for rare earth carbides and specific isotopic labeling.

Email: [info@benchchem.com](mailto:info@benchchem.com) or [Request Quote Online](#).

## References

- 1. benchchem.com [benchchem.com]
- 2. Cucurbitane-Type Triterpenoids from the Vines of Momordica charantia and Their Anti-inflammatory Activities - PMC [pmc.ncbi.nlm.nih.gov]
- 3. benchchem.com [benchchem.com]
- 4. Antidiabetic activities of triterpenoids isolated from bitter melon associated with activation of the AMPK pathway - PubMed [pubmed.ncbi.nlm.nih.gov]
- To cite this document: BenchChem. [Application Notes and Protocols for a Cellular Analysis of Momordicoside X]. BenchChem, [2025]. [Online PDF]. Available at: [https://www.benchchem.com/product/b15592252#cell-culture-protocols-for-testing-momordicoside-x]

---

### Disclaimer & Data Validity:

The information provided in this document is for Research Use Only (RUO) and is strictly not intended for diagnostic or therapeutic procedures. While BenchChem strives to provide accurate protocols, we make no warranties, express or implied, regarding the fitness of this product for every specific experimental setup.

**Technical Support:** The protocols provided are for reference purposes. Unsure if this reagent suits your experiment? [[Contact our Ph.D. Support Team for a compatibility check](#)]

**Need Industrial/Bulk Grade?** [Request Custom Synthesis Quote](#)

# BenchChem

Our mission is to be the trusted global source of essential and advanced chemicals, empowering scientists and researchers to drive progress in science and industry.

## Contact

Address: 3281 E Guasti Rd  
Ontario, CA 91761, United States  
Phone: (601) 213-4426  
Email: [info@benchchem.com](mailto:info@benchchem.com)