

Gelsevirine as a STING Inhibitor: A Technical Guide

Author: BenchChem Technical Support Team. **Date:** December 2025

Compound of Interest

Compound Name: Gelsevirine

Cat. No.: B15591289

[Get Quote](#)

For Researchers, Scientists, and Drug Development Professionals

Abstract

The Stimulator of Interferon Genes (STING) pathway is a critical component of the innate immune system, responsible for detecting cytosolic DNA and initiating a robust inflammatory and interferon response. While essential for host defense, aberrant STING activation is implicated in the pathophysiology of various inflammatory and autoimmune diseases. Consequently, the development of STING inhibitors has emerged as a promising therapeutic strategy. **Gelsevirine**, a natural alkaloid, has been identified as a novel and specific inhibitor of STING. This technical guide provides an in-depth overview of **Gelsevirine**'s mechanism of action, supported by quantitative data and detailed experimental methodologies. Visual diagrams of signaling pathways and experimental workflows are included to facilitate a comprehensive understanding of **Gelsevirine** as a potential therapeutic agent targeting the STING pathway.

Introduction to the STING Signaling Pathway

The cGAS-STING pathway is a key innate immune sensing pathway that responds to the presence of cytosolic double-stranded DNA (dsDNA), a danger signal associated with viral and bacterial infections, as well as cellular damage. Upon binding to dsDNA, cyclic GMP-AMP synthase (cGAS) catalyzes the synthesis of the second messenger 2'3'-cyclic GMP-AMP (2'3'-cGAMP). 2'3'-cGAMP then binds to the STING protein, which is anchored to the endoplasmic reticulum (ER) membrane. This binding event triggers a conformational change in STING,

leading to its dimerization and translocation from the ER to the Golgi apparatus. In the Golgi, STING recruits and activates TANK-binding kinase 1 (TBK1), which in turn phosphorylates both STING and the transcription factor Interferon Regulatory Factor 3 (IRF3). Phosphorylated IRF3 dimerizes and translocates to the nucleus, where it induces the expression of type I interferons (IFN- α/β) and other inflammatory cytokines.

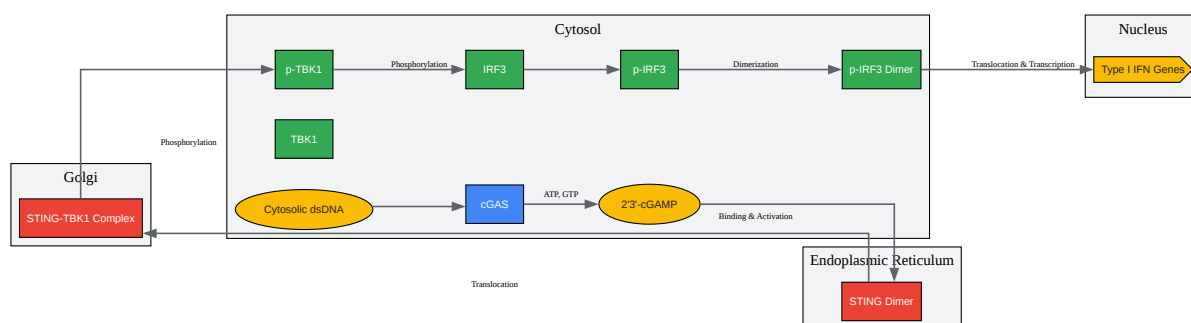

[Click to download full resolution via product page](#)

Figure 1: The cGAS-STING signaling pathway.

Gelsevirine: A Dual-Action STING Inhibitor

Gelsevirine has been identified as a potent and specific inhibitor of the STING signaling pathway through a dual mechanism of action.[1][2] Firstly, it acts as a competitive inhibitor by directly binding to the cyclic dinucleotide (CDN)-binding pocket of STING.[1][2] This competitive binding prevents the natural ligand, 2'3'-cGAMP, from activating STING, thereby locking the STING dimer in an inactive conformation.[1][2] Secondly, **Gelsevirine** promotes the K48-linked ubiquitination and subsequent proteasomal degradation of STING, a process likely mediated

by the E3 ubiquitin ligase TRIM21.[1][2][3] This dual action of both blocking activation and promoting degradation makes **Gelsevirine** a highly effective inhibitor of the STING pathway.

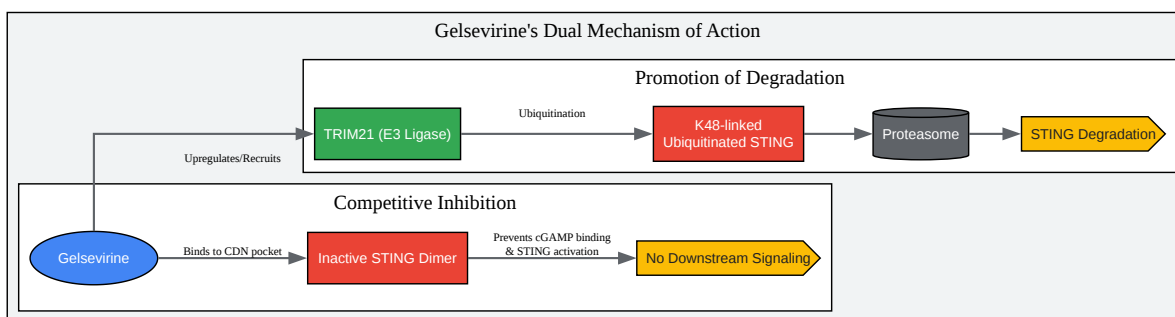

[Click to download full resolution via product page](#)

Figure 2: Dual mechanism of **Gelsevirine** as a STING inhibitor.

Quantitative Data

The inhibitory activity of **Gelsevirine** on the STING pathway has been quantified through various in vitro assays. The following tables summarize the key quantitative data.

Table 1: In Vitro Inhibitory Activity of **Gelsevirine**

Parameter	Cell Line	STING Agonist	Value	Reference
IC50 (IFN- β mRNA)	Raw264.7 (murine macrophage)	2'3'-cGAMP	5.365 μ M	[4]

| IC50 (IFN- β mRNA) | THP-1 (human monocytic) | 2'3'-cGAMP | 0.766 μ M |[4] |

Table 2: **Gelsevirine**-STING Binding Affinity

Assay	STING Protein	Parameter	Value	Reference
-------	---------------	-----------	-------	-----------

| Surface Plasmon Resonance (SPR) | Human STING-CTD | Kd | 27.6 μ M |[1] |

Detailed Experimental Protocols

This section provides detailed methodologies for the key experiments used to characterize **Gelsevirine** as a STING inhibitor.

Surface Plasmon Resonance (SPR) Assay for Binding Affinity

This protocol outlines the determination of the binding affinity between **Gelsevirine** and the C-terminal domain (CTD) of human STING using SPR.

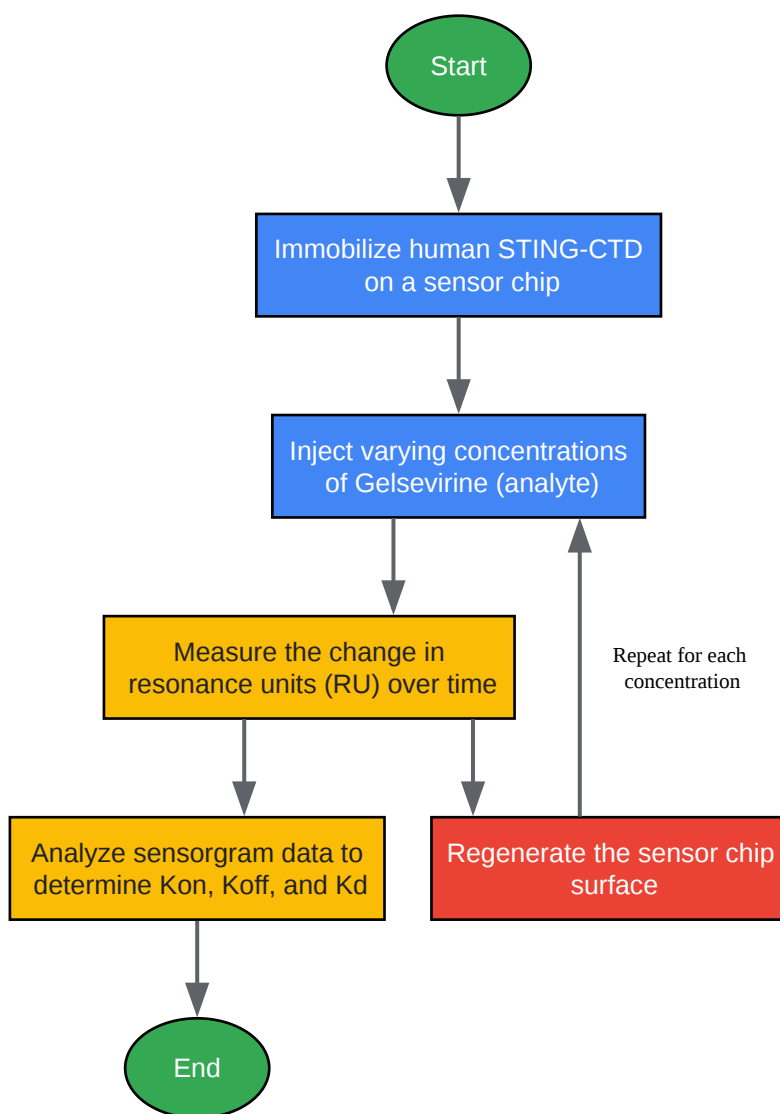

[Click to download full resolution via product page](#)

Figure 3: Workflow for Surface Plasmon Resonance (SPR) assay.

Materials:

- Biacore instrument
- Sensor chip (e.g., CM5)
- Human STING C-terminal domain (CTD) protein (ligand)
- **Gelsevirine** (analyte)

- Amine coupling kit (EDC, NHS, ethanolamine)
- Running buffer (e.g., HBS-EP+)
- Regeneration solution (e.g., Glycine-HCl, pH 2.5)

Procedure:

- Ligand Immobilization:
 - Equilibrate the sensor chip with running buffer.
 - Activate the carboxymethylated dextran surface of the sensor chip by injecting a 1:1 mixture of 0.4 M EDC and 0.1 M NHS.
 - Inject the human STING-CTD protein (typically at 10-50 µg/mL in a low ionic strength buffer, e.g., 10 mM sodium acetate, pH 4.5) over the activated surface.
 - Deactivate any remaining active esters by injecting 1 M ethanolamine-HCl, pH 8.5.
- Analyte Binding:
 - Prepare a series of **Gelsevirine** dilutions in running buffer (e.g., ranging from 0.1 to 100 µM).
 - Inject each concentration of **Gelsevirine** over the immobilized STING-CTD surface for a defined association time, followed by a dissociation phase with running buffer.
- Data Analysis:
 - Record the sensorgrams for each **Gelsevirine** concentration.
 - Fit the binding data to a suitable model (e.g., a 1:1 steady-state binding model) to calculate the association rate constant (k_{on}), dissociation rate constant (k_{off}), and the equilibrium dissociation constant (K_d).^[1]

Biotin Pull-Down Assay for Competitive Binding

This assay confirms the direct and competitive binding of **Gelsevirine** to STING protein.

Materials:

- Biotinylated **Gelsevirine** (Biotin-GS)
- HEK293T cells overexpressing HA-tagged STING
- Streptavidin-conjugated beads (e.g., magnetic beads)
- Lysis buffer (e.g., RIPA buffer with protease inhibitors)
- Wash buffer (e.g., PBS with 0.1% Tween-20)
- Unlabeled **Gelsevirine** and 2'3'-cGAMP for competition
- Anti-HA antibody for Western blotting

Procedure:

- Cell Lysate Preparation:
 - Transfect HEK293T cells with a plasmid expressing HA-tagged STING.
 - After 24-48 hours, lyse the cells with lysis buffer and collect the supernatant containing the HA-STING protein.
- Binding and Competition:
 - Incubate the cell lysate with biotinylated **Gelsevirine** (e.g., 5 μ M) for 1 hour.
 - For competition experiments, pre-incubate the lysate with a 10-fold excess of unlabeled **Gelsevirine** or 2'3'-cGAMP before adding biotinylated **Gelsevirine**.
- Pull-Down:
 - Add streptavidin-conjugated beads to the lysate mixture and incubate for 1-2 hours at 4°C with rotation to capture the biotin-GS-STING complexes.
 - Wash the beads several times with wash buffer to remove non-specific binding proteins.

- Analysis:
 - Elute the bound proteins from the beads by boiling in SDS-PAGE sample buffer.
 - Analyze the eluate by Western blotting using an anti-HA antibody to detect the presence of STING. A decrease in the STING band in the presence of unlabeled **Gelsevirine** or 2'3'-cGAMP indicates competitive binding.[1][2]

In Vitro Ubiquitination Assay

This protocol is designed to demonstrate that **Gelsevirine** promotes the K48-linked ubiquitination of STING.

Materials:

- HEK293T cells
- Plasmids expressing HA-tagged STING and Flag-tagged ubiquitin (or K48-only ubiquitin)
- **Gelsevirine**
- Lysis buffer for immunoprecipitation
- Anti-HA antibody for immunoprecipitation
- Protein A/G agarose beads
- Anti-Flag and anti-K48-linkage specific ubiquitin antibodies for Western blotting

Procedure:

- Cell Transfection and Treatment:
 - Co-transfect HEK293T cells with plasmids expressing HA-STING and Flag-ubiquitin.
 - After 24 hours, treat the cells with **Gelsevirine** (e.g., 10 μ M) or vehicle for 2-4 hours.
- Immunoprecipitation:

- Lyse the cells and immunoprecipitate HA-STING using an anti-HA antibody and protein A/G beads.
 - Wash the immunoprecipitates thoroughly.
 - Western Blot Analysis:
 - Elute the immunoprecipitated proteins and resolve them by SDS-PAGE.
 - Perform Western blotting with an anti-Flag antibody to detect total ubiquitinated STING and an anti-K48-linkage specific ubiquitin antibody to specifically detect K48-linked ubiquitination. An increased signal for K48-linked ubiquitin in the **Gelsevirine**-treated sample indicates that **Gelsevirine** promotes this specific type of ubiquitination on STING.
- [1][2]

Native PAGE for STING Dimerization

This method is used to assess the effect of **Gelsevirine** on STING dimerization upon activation.

Materials:

- Raw264.7 cells
- **Gelsevirine**
- 2'3'-cGAMP
- Lysis buffer for native PAGE (without denaturing agents like SDS)
- Native-PAGE gel and running buffer
- Anti-STING antibody for Western blotting

Procedure:

- Cell Treatment:
 - Pre-treat Raw264.7 cells with **Gelsevirine** (e.g., 10 μ M) for 6 hours.

- Stimulate the cells with 2'3'-cGAMP (e.g., 5 µg/ml) for 1-3 hours.
- Sample Preparation and Electrophoresis:
 - Lyse the cells in native lysis buffer.
 - Mix the lysates with native loading buffer and run on a native-PAGE gel.
- Western Blot Analysis:
 - Transfer the proteins to a PVDF membrane and perform Western blotting with an anti-STING antibody.
 - In the absence of **Gelsevirine**, 2'3'-cGAMP stimulation will induce a shift in the STING band to a higher molecular weight, indicating dimerization. Inhibition of this shift by **Gelsevirine** demonstrates its ability to prevent STING dimerization.[\[1\]](#)

In Vivo Cecal Ligation and Puncture (CLP) Sepsis Model

This in vivo model is used to evaluate the therapeutic efficacy of **Gelsevirine** in a clinically relevant model of sepsis, a condition where STING activation plays a detrimental role.[\[1\]](#)[\[2\]](#)

Animals:

- C57BL/6J mice

Procedure:

- Anesthesia and Surgery:
 - Anesthetize the mice (e.g., with isoflurane or ketamine/xylazine).
 - Make a midline laparotomy incision to expose the cecum.
 - Ligate the cecum below the ileocecal valve. The position of the ligation can be varied to modulate the severity of sepsis.
 - Puncture the ligated cecum with a needle (e.g., 21-gauge). The number and size of punctures also determine the severity.

- Gently squeeze the cecum to extrude a small amount of fecal content.
- Return the cecum to the peritoneal cavity and close the incision.
- **Gelsevirine Administration:**
 - Administer **Gelsevirine** (e.g., 10 or 20 mg/kg) or vehicle intraperitoneally at a defined time point post-CLP surgery (e.g., 5 hours).[5]
- **Monitoring and Analysis:**
 - Monitor the mice for survival over several days.
 - At specific time points, sacrifice subgroups of mice and collect blood and organs (e.g., lungs, liver, kidneys) for analysis of inflammatory markers (e.g., cytokines by ELISA), organ damage (histology), and STING pathway activation (Western blot for p-TBK1, p-IRF3).[1]

Conclusion

Gelsevirine presents a compelling profile as a STING inhibitor with a novel dual mechanism of action. By both competitively inhibiting STING activation and promoting its degradation, **Gelsevirine** effectively attenuates the inflammatory and interferon responses mediated by the STING pathway. The quantitative data and detailed experimental protocols provided in this guide offer a comprehensive resource for researchers and drug development professionals interested in further investigating and potentially developing **Gelsevirine** as a therapeutic agent for STING-driven diseases. The promising in vivo efficacy in a sepsis model underscores its potential for clinical translation. Further studies are warranted to explore its therapeutic utility in a broader range of inflammatory and autoimmune conditions.

Need Custom Synthesis?

BenchChem offers custom synthesis for rare earth carbides and specific isotopic labeling.

Email: info@benchchem.com or [Request Quote Online](#).

References

- 1. researchgate.net [researchgate.net]
- 2. Gelsevirine is a novel STING-specific inhibitor and mitigates STING-related inflammation in sepsis - PubMed [pubmed.ncbi.nlm.nih.gov]
- 3. researchgate.net [researchgate.net]
- 4. Inducing Experimental Polymicrobial Sepsis by Cecal Ligation and Puncture - PMC [pmc.ncbi.nlm.nih.gov]
- 5. Frontiers | Gelsevirine is a novel STING-specific inhibitor and mitigates STING-related inflammation in sepsis [frontiersin.org]
- To cite this document: BenchChem. [Gelsevirine as a STING Inhibitor: A Technical Guide]. BenchChem, [2025]. [Online PDF]. Available at: [https://www.benchchem.com/product/b15591289#gelsevirine-as-a-sting-inhibitor]

Disclaimer & Data Validity:

The information provided in this document is for Research Use Only (RUO) and is strictly not intended for diagnostic or therapeutic procedures. While BenchChem strives to provide accurate protocols, we make no warranties, express or implied, regarding the fitness of this product for every specific experimental setup.

Technical Support: The protocols provided are for reference purposes. Unsure if this reagent suits your experiment? [[Contact our Ph.D. Support Team for a compatibility check](#)]

Need Industrial/Bulk Grade? [Request Custom Synthesis Quote](#)

BenchChem

Our mission is to be the trusted global source of essential and advanced chemicals, empowering scientists and researchers to drive progress in science and industry.

Contact

Address: 3281 E Guasti Rd
Ontario, CA 91761, United States
Phone: (601) 213-4426
Email: info@benchchem.com