

Benchmarking PRMT5 Inhibitors: A Comparative Guide for Researchers

Author: BenchChem Technical Support Team. **Date:** April 2026

Compound of Interest

Compound Name: *Prmt5-IN-37*

Cat. No.: *B15589400*

[Get Quote](#)

For researchers, scientists, and drug development professionals, this guide provides an objective comparison of PRMT5 inhibitors against other key epigenetic modifiers. Experimental data and detailed protocols support the analysis, offering a comprehensive resource for evaluating therapeutic potential.

Protein Arginine Methyltransferase 5 (PRMT5) has emerged as a critical epigenetic regulator and a promising therapeutic target in oncology.[1][2] Overexpressed in a variety of cancers, including lymphoma, breast, lung, and colorectal cancers, its activity is often correlated with poor prognosis.[3][4] PRMT5 functions as a Type II arginine methyltransferase, catalyzing the symmetric dimethylation of arginine residues on both histone and non-histone proteins. This post-translational modification plays a pivotal role in regulating a multitude of cellular processes, from gene transcription and RNA splicing to DNA damage repair and signal transduction.[1][4]

The therapeutic potential of targeting PRMT5 has led to the development of numerous small molecule inhibitors. While specific data for "**Prmt5-IN-37**" is not publicly available, this guide will benchmark the performance of the PRMT5 inhibitor class against other well-established epigenetic modifiers, providing a framework for experimental evaluation.

Comparative Analysis of Epigenetic Modifiers

The following table summarizes the key characteristics of PRMT5 inhibitors in comparison to other major classes of epigenetic modifiers: Histone Deacetylase (HDAC) inhibitors, DNA Methyltransferase (DNMT) inhibitors, and Bromodomain and Extra-Terminal motif (BET) inhibitors.

Feature	PRMT5 Inhibitors	HDAC Inhibitors	DNMT Inhibitors	BET Inhibitors
Target Enzyme/Protein	Protein Arginine Methyltransferase 5 (PRMT5)	Histone Deacetylases (HDACs)	DNA Methyltransferases (DNMTs)	Bromodomain and Extra-Terminal (BET) proteins (BRD2, BRD3, BRD4, BRDT)
Primary Epigenetic Mark	Symmetric dimethylarginine (sDMA) on histones (e.g., H4R3, H3R8) and non-histone proteins	Histone acetylation	DNA methylation (5-methylcytosine)	Recognition of acetylated histones
Mechanism of Action	Inhibit the catalytic activity of PRMT5, preventing the transfer of methyl groups from S-adenosylmethionine (SAM) to arginine residues.[4]	Block the removal of acetyl groups from histones, leading to histone hyperacetylation and a more open chromatin structure.[5][6]	Incorporate into DNA and trap DNMTs, leading to their degradation and subsequent DNA hypomethylation. [7][8]	Competitively bind to the bromodomains of BET proteins, preventing them from binding to acetylated histones and disrupting transcription.[1][9]
Effect on Gene Expression	Primarily leads to the derepression of tumor suppressor genes silenced by PRMT5-mediated histone methylation.	Generally leads to transcriptional activation by promoting a relaxed chromatin state. [6]	Reactivates silenced tumor suppressor genes by reversing promoter hypermethylation. [7]	Downregulates the expression of key oncogenes (e.g., MYC) and pro-inflammatory genes.[10][11]

Examples of (Pre)Clinical Compounds	GSK3326595, JNJ-64619178, AMG 193, PRT811[2][3][4]	Vorinostat, Romidepsin, Panobinostat[12]	Azacitidine, Decitabine[7][13]	OTX015, CPI-0610, JQ1[9]
Reported Cellular Effects	Induction of apoptosis, cell cycle arrest, and senescence in cancer cells.[14] [15]	Cell cycle arrest, induction of apoptosis, and differentiation.[5] [16]	Reactivation of tumor suppressor genes, induction of apoptosis, and enhanced tumor immunogenicity. [17]	Inhibition of cancer cell proliferation, induction of apoptosis, and anti-inflammatory effects.[10]

Experimental Protocols for Benchmarking

To rigorously evaluate a novel PRMT5 inhibitor such as **Prmt5-IN-37**, a series of biochemical and cellular assays are essential. The following protocols provide a detailed methodology for key experiments.

Biochemical PRMT5 Activity Assay (TR-FRET)

This assay directly measures the enzymatic activity of PRMT5 and its inhibition.

Materials:

- Purified recombinant human PRMT5/MEP50 complex
- Histone H4 peptide (1-21) substrate
- S-adenosylmethionine (SAM)
- TR-FRET detection reagents (e.g., antibody specific for symmetrically dimethylated H4R3 and a corresponding donor/acceptor pair)
- Assay buffer (e.g., 20 mM Tris-HCl pH 8.0, 50 mM NaCl, 1 mM EDTA, 3 mM MgCl₂, 0.01% Brij-35, 1 mM DTT)

- 384-well assay plates

Procedure:

- Prepare serial dilutions of the PRMT5 inhibitor in the assay buffer.
- Add the PRMT5/MEP50 complex and the histone H4 peptide substrate to the wells of the 384-well plate.
- Add the PRMT5 inhibitor dilutions to the respective wells.
- Initiate the reaction by adding SAM.
- Incubate the plate at 30°C for a predetermined time (e.g., 60 minutes).
- Stop the reaction by adding the TR-FRET detection reagents.
- Incubate at room temperature for 60 minutes to allow for antibody binding.
- Measure the TR-FRET signal using a plate reader.
- Calculate the IC50 value by plotting the percentage of inhibition against the inhibitor concentration.

Cellular Assay for Symmetric Di-Methyl Arginine (sDMA) Levels by Western Blot

This assay assesses the ability of the inhibitor to block PRMT5 activity within a cellular context.

Materials:

- Cancer cell line of interest (e.g., a line with known PRMT5 dependency)
- PRMT5 inhibitor
- Cell lysis buffer (e.g., RIPA buffer with protease and phosphatase inhibitors)

- Primary antibodies: anti-sDMA (symmetric dimethylarginine), anti-H4R3me2s, anti-total Histone H4 (as a loading control)
- HRP-conjugated secondary antibody
- Chemiluminescent substrate
- Western blotting equipment

Procedure:

- Seed cells in a 6-well plate and allow them to adhere overnight.
- Treat the cells with varying concentrations of the PRMT5 inhibitor for a specific duration (e.g., 48-72 hours).
- Lyse the cells and quantify the protein concentration.
- Separate 20-30 μg of protein per sample by SDS-PAGE and transfer to a PVDF membrane.
- Block the membrane with 5% non-fat milk or BSA in TBST for 1 hour.[\[18\]](#)
- Incubate the membrane with the primary antibody (e.g., anti-sDMA or anti-H4R3me2s) overnight at 4°C.[\[18\]](#)
- Wash the membrane and incubate with the HRP-conjugated secondary antibody for 1 hour at room temperature.[\[18\]](#)
- Visualize the protein bands using a chemiluminescent substrate.
- Quantify the band intensities and normalize to the total histone H4 loading control to determine the dose-dependent reduction in sDMA levels.

Cell Viability Assay (MTT Assay)

This assay determines the cytotoxic effect of the PRMT5 inhibitor on cancer cells.

Materials:

- Cancer cell line
- PRMT5 inhibitor
- Complete culture medium
- MTT (3-(4,5-dimethylthiazol-2-yl)-2,5-diphenyltetrazolium bromide) solution
- DMSO
- 96-well plates

Procedure:

- Seed cells in a 96-well plate at a suitable density and incubate overnight.
- Treat the cells with a range of concentrations of the PRMT5 inhibitor. Include a vehicle control (e.g., DMSO).
- Incubate the plate for 72 hours.[\[14\]](#)
- Add MTT solution to each well and incubate for 4 hours at 37°C.[\[19\]](#)
- Add DMSO to dissolve the formazan crystals.
- Measure the absorbance at 570 nm using a microplate reader.
- Calculate the cell viability as a percentage of the vehicle-treated control and determine the IC50 value.

Visualizing PRMT5's Role and Experimental Design

To further elucidate the context of PRMT5 inhibition, the following diagrams, generated using the DOT language for Graphviz, illustrate a key signaling pathway involving PRMT5 and a typical experimental workflow for inhibitor benchmarking.

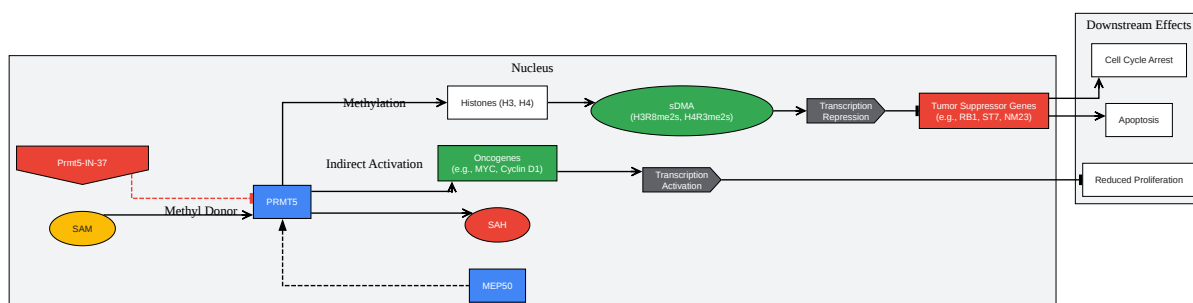

[Click to download full resolution via product page](#)

Caption: PRMT5 signaling pathway and the point of inhibition.

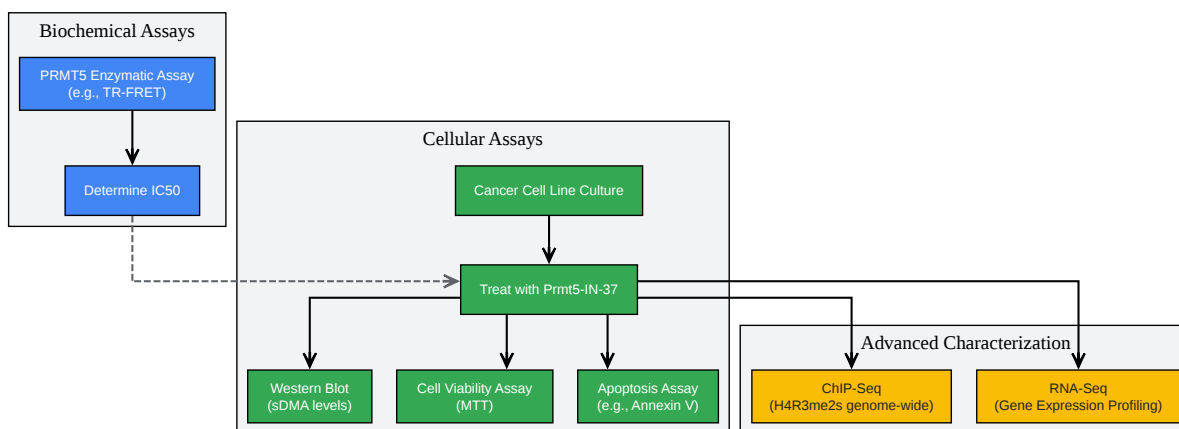

[Click to download full resolution via product page](#)

Caption: A typical experimental workflow for benchmarking a PRMT5 inhibitor.

Need Custom Synthesis?

BenchChem offers custom synthesis for rare earth carbides and specific isotopic labeling.

Email: info@benchchem.com or [Request Quote Online](#).

References

- [1. BET inhibitor - Wikipedia \[en.wikipedia.org\]](#)
- [2. Protein Arginine Methyltransferase 5 \(PRMT5\) Inhibitors in Oncology Clinical Trials: A review - PubMed \[pubmed.ncbi.nlm.nih.gov\]](#)
- [3. onclive.com \[onclive.com\]](#)
- [4. mdpi.com \[mdpi.com\]](#)

- 5. Histone deacetylase inhibitors: molecular mechanisms of action and clinical trials as anti-cancer drugs - PMC [pmc.ncbi.nlm.nih.gov]
- 6. What are HDAC inhibitors and how do they work? [synapse.patsnap.com]
- 7. What are DNA methyltransferase inhibitors and how do they work? [synapse.patsnap.com]
- 8. What are DNMT1 inhibitors and how do they work? [synapse.patsnap.com]
- 9. What are BET inhibitors and how do they work? [synapse.patsnap.com]
- 10. The mechanisms behind the therapeutic activity of BET bromodomain inhibition - PMC [pmc.ncbi.nlm.nih.gov]
- 11. aacrjournals.org [aacrjournals.org]
- 12. aacrjournals.org [aacrjournals.org]
- 13. DNA Methyltransferase Inhibitors and Their Emerging Role in Epigenetic Therapy of Cancer | Anticancer Research [ar.iiarjournals.org]
- 14. Structure-Based Discovery and Biological Assays of a Novel PRMT5 Inhibitor for Non-Small Cell Lung Cancer - PMC [pmc.ncbi.nlm.nih.gov]
- 15. Identification of a Selective Cell-Active Inhibitor of Protein Arginine Methyltransferase 5 (PRMT5) for the Treatment of Prostate Cancer by Structure-Based Virtual Screening - PMC [pmc.ncbi.nlm.nih.gov]
- 16. mdpi.com [mdpi.com]
- 17. mdpi.com [mdpi.com]
- 18. benchchem.com [benchchem.com]
- 19. benchchem.com [benchchem.com]
- To cite this document: BenchChem. [Benchmarking PRMT5 Inhibitors: A Comparative Guide for Researchers]. BenchChem, [2026]. [Online PDF]. Available at: [https://www.benchchem.com/product/b15589400/docs#benchmarking-prmt5-inhibitors-a-comparative-guide-for-researchers]

Disclaimer & Data Validity:

The information provided in this document is for Research Use Only (RUO) and is strictly not intended for diagnostic or therapeutic procedures. While BenchChem strives to provide accurate protocols, we make no warranties, express or implied, regarding the fitness of this product for every specific experimental setup.

Technical Support: The protocols provided are for reference purposes. Unsure if this reagent suits your experiment?

Need Industrial/Bulk Grade? [Request Custom Synthesis Quote](#)

BenchChem

Our mission is to be the trusted global source of essential and advanced chemicals, empowering scientists and researchers to drive progress in science and industry.

Contact

Address: 3281 E Guasti Rd
Ontario, CA 91761, United States
Phone: (601) 213-4426
Email: info@benchchem.com

[Contact our Ph.D. Support Team for a compatibility check](#)