

Application Notes and Protocols for NSC636819

Author: BenchChem Technical Support Team. **Date:** April 2026

Compound of Interest

Compound Name: NSC636819

Cat. No.: B15589291

[Get Quote](#)

For Researchers, Scientists, and Drug Development Professionals

Introduction

NSC636819 is a potent and selective cell-permeable inhibitor of the histone lysine demethylases KDM4A and KDM4B.[1] It competitively inhibits the demethylation of H3K9me3, leading to the induction of apoptosis in cancer cells, such as LNCaP prostate cancer cells.[2]

NSC636819 also negatively regulates androgen-responsive genes, highlighting its therapeutic potential in prostate and other hormone-dependent cancers.[3] Given its promising biological activity, understanding the long-term stability of **NSC636819** in solution is critical for ensuring the reliability and reproducibility of experimental results, as well as for its potential development as a therapeutic agent.

These application notes provide a comprehensive overview of the known stability of **NSC636819** in solution, based on currently available data. Furthermore, detailed protocols for proposed long-term and forced degradation stability studies are presented to enable researchers to generate robust and reliable stability data for their specific applications. A validated stability-indicating analytical method is essential for accurately quantifying the active pharmaceutical ingredient (API) without interference from degradation products, impurities, or excipients.[4]

Chemical and Physical Properties

A summary of the key chemical and physical properties of **NSC636819** is provided in the table below.

Property	Value	Reference
Molecular Formula	C ₂₂ H ₁₂ Cl ₄ N ₂ O ₄	
Molecular Weight	510.15 g/mol	
CAS Number	1618672-71-1	
Appearance	Solid powder	
Purity	≥98% (HPLC)	
Solubility	Soluble to 10 mM in DMSO	

Known Stability and Storage Conditions

Based on manufacturer recommendations and available data, the following storage conditions are advised for **NSC636819** and its solutions.

Form	Solvent	Storage Temperature	Reported Stability
Solid Powder	-	+4°C	Long-term
Stock Solution	DMSO	-20°C	Up to 3 months
Stock Solution	DMSO	-80°C	Up to 6 months

Note: For optimal stability, it is recommended to prepare fresh solutions for use in cell-based assays and other sensitive experiments. Avoid repeated freeze-thaw cycles of stock solutions.

Proposed Long-Term and Accelerated Stability Study

To rigorously assess the long-term stability of **NSC636819** in solution, a comprehensive stability study is recommended. The following table outlines the proposed conditions for both long-term and accelerated stability testing, based on ICH guidelines.[5][6]

Study Type	Storage Condition	Time Points (Months)
Long-Term	5°C ± 3°C	0, 3, 6, 9, 12, 18, 24
Accelerated	25°C ± 2°C / 60% RH ± 5% RH	0, 3, 6
Accelerated	40°C ± 2°C / 75% RH ± 5% RH	0, 3, 6

Experimental Protocols

Protocol 1: Preparation of **NSC636819** Stock Solution

- Materials:
 - **NSC636819** solid powder
 - Anhydrous Dimethyl Sulfoxide (DMSO), HPLC grade or higher
 - Sterile, amber glass vials with screw caps
 - Calibrated analytical balance
 - Vortex mixer
- Procedure:
 1. Equilibrate the **NSC636819** vial to room temperature before opening to prevent moisture condensation.
 2. Accurately weigh the desired amount of **NSC636819** powder using a calibrated analytical balance.

3. Dissolve the powder in the appropriate volume of anhydrous DMSO to achieve the desired stock concentration (e.g., 10 mM).
4. Vortex the solution until the **NSC636819** is completely dissolved.
5. Aliquot the stock solution into sterile, amber glass vials to minimize exposure to light and air.
6. Store the aliquots at -20°C or -80°C for long-term storage.

Protocol 2: Proposed Stability-Indicating HPLC Method

A stability-indicating High-Performance Liquid Chromatography (HPLC) method is crucial for separating and quantifying **NSC636819** from its potential degradation products.[7][8]

- Instrumentation and Conditions:
 - HPLC System: A system equipped with a quaternary pump, autosampler, column oven, and a photodiode array (PDA) detector.
 - Column: A C18 reversed-phase column (e.g., 4.6 x 150 mm, 5 µm particle size).
 - Mobile Phase A: 0.1% Formic acid in water.
 - Mobile Phase B: 0.1% Formic acid in acetonitrile.
 - Gradient Elution:

Time (min)	% Mobile Phase B
0	10
20	90
25	90
26	10

| 30 | 10 |

- Flow Rate: 1.0 mL/min.
- Column Temperature: 30°C.
- Detection Wavelength: Monitor at the λ_{max} of **NSC636819** (to be determined by UV-Vis spectroscopy) and at a lower wavelength (e.g., 210 nm) to detect potential degradation products that may not absorb at the λ_{max} .
- Injection Volume: 10 μL .
- Sample Preparation for Analysis:
 1. At each time point of the stability study, retrieve a vial of **NSC636819** solution from the respective storage condition.
 2. Allow the vial to equilibrate to room temperature.
 3. Dilute the sample to a suitable concentration within the linear range of the HPLC method using the mobile phase as the diluent.
 4. Inject the diluted sample into the HPLC system.
- Data Analysis:
 1. Integrate the peak area of **NSC636819** and any degradation products.
 2. Calculate the percentage of **NSC636819** remaining at each time point relative to the initial time point (T=0).
 3. Assess for the appearance of new peaks, which may indicate degradation products.

Protocol 3: Forced Degradation Studies

Forced degradation studies are essential to identify potential degradation pathways and to demonstrate the specificity of the stability-indicating method.^{[9][10][11]} The goal is to achieve 5-20% degradation of the drug substance.

- Acid Hydrolysis:

1. Prepare a solution of **NSC636819** in a mixture of DMSO and 0.1 M HCl.
 2. Incubate the solution at 60°C and collect samples at various time points (e.g., 0, 2, 4, 8, 24 hours).
 3. Neutralize the samples with 0.1 M NaOH before HPLC analysis.
- Base Hydrolysis:
 1. Prepare a solution of **NSC636819** in a mixture of DMSO and 0.1 M NaOH.
 2. Incubate the solution at 60°C and collect samples at various time points.
 3. Neutralize the samples with 0.1 M HCl before HPLC analysis.
 - Oxidative Degradation:
 1. Prepare a solution of **NSC636819** in a mixture of DMSO and 3% hydrogen peroxide (H₂O₂).
 2. Keep the solution at room temperature and collect samples at various time points.
 3. Analyze the samples directly by HPLC.
 - Thermal Degradation:
 1. Store a solution of **NSC636819** in DMSO at an elevated temperature (e.g., 70°C).
 2. Collect samples at various time points for HPLC analysis.
 - Photolytic Degradation:
 1. Expose a solution of **NSC636819** in DMSO to a light source with a specific wavelength (e.g., UV-A at 365 nm and cool white fluorescent lamp) in a photostability chamber.
 2. A control sample should be wrapped in aluminum foil to protect it from light.
 3. Collect samples at various time points for HPLC analysis.

Visualizations

Signaling Pathway of KDM4A/B Inhibition by NSC636819

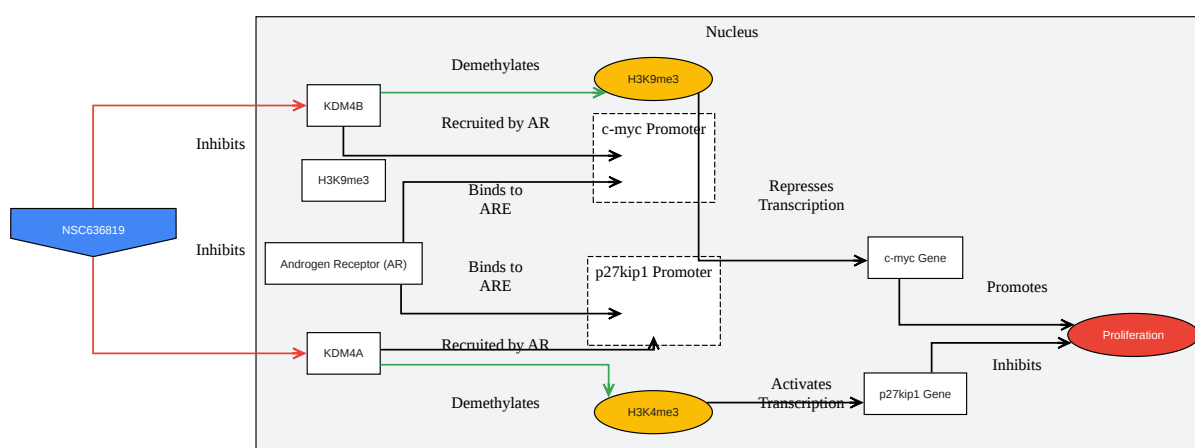

[Click to download full resolution via product page](#)

Caption: KDM4A/B Signaling Pathway and **NSC636819** Inhibition.

Experimental Workflow for Stability Testing

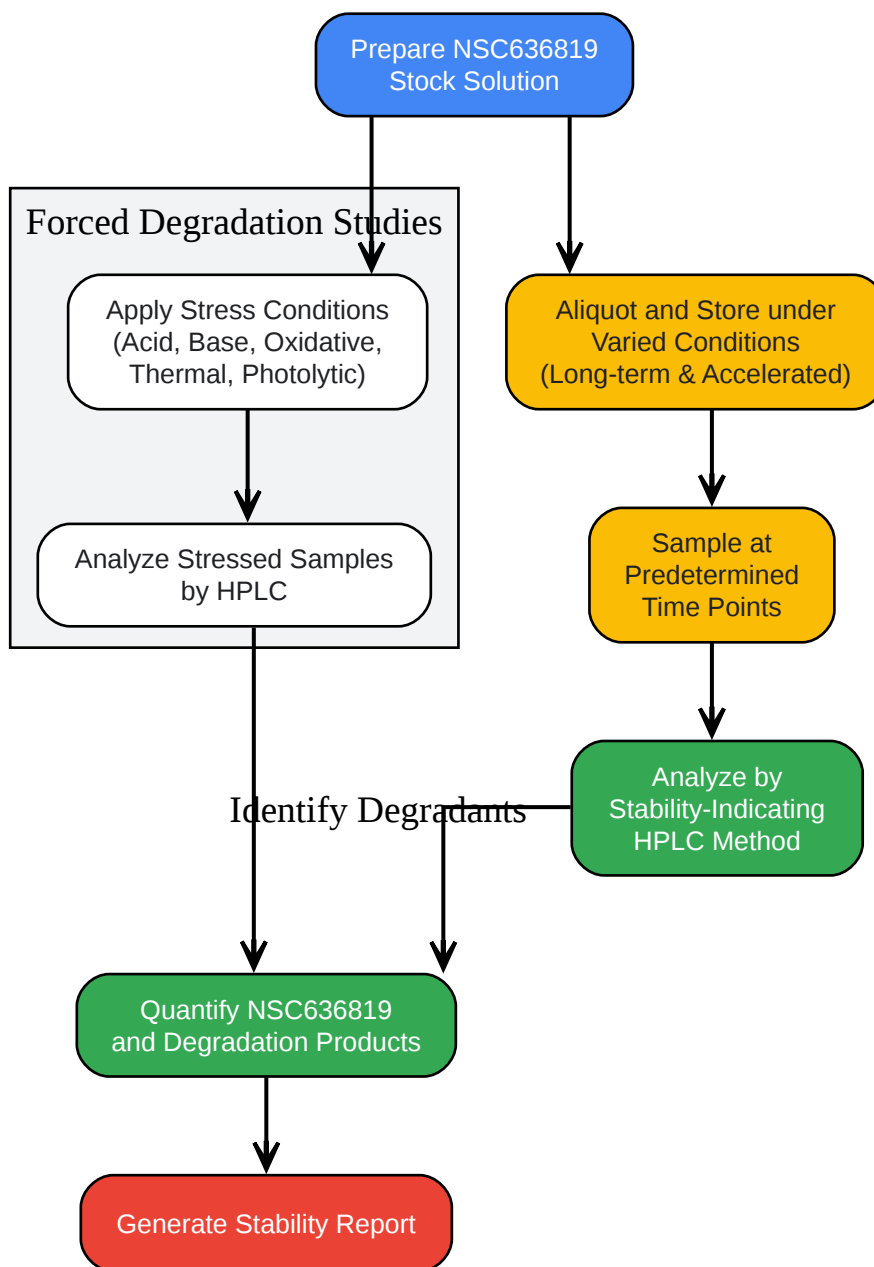

[Click to download full resolution via product page](#)

Caption: Workflow for **NSC636819** Stability Assessment.

Need Custom Synthesis?

BenchChem offers custom synthesis for rare earth carbides and specific isotopic labeling.
 Email: info@benchchem.com or [Request Quote Online](#).

References

- [1. medchemexpress.com \[medchemexpress.com\]](#)
- [2. KDM4B as a Target for Prostate Cancer: Structural Analysis and Selective Inhibition by a Novel Inhibitor - PMC \[pmc.ncbi.nlm.nih.gov\]](#)
- [3. pdfs.semanticscholar.org \[pdfs.semanticscholar.org\]](#)
- [4. benchchem.com \[benchchem.com\]](#)
- [5. chromatographyonline.com \[chromatographyonline.com\]](#)
- [6. www3.paho.org \[www3.paho.org\]](#)
- [7. chromatographyonline.com \[chromatographyonline.com\]](#)
- [8. Development of forced degradation and stability indicating studies of drugs—A review - PMC \[pmc.ncbi.nlm.nih.gov\]](#)
- [9. americanpharmaceuticalreview.com \[americanpharmaceuticalreview.com\]](#)
- [10. ijarsct.co.in \[ijarsct.co.in\]](#)
- [11. pharmtech.com \[pharmtech.com\]](#)
- [To cite this document: BenchChem. \[Application Notes and Protocols for NSC636819\]. BenchChem, \[2026\]. \[Online PDF\]. Available at: \[https://www.benchchem.com/product/b15589291/docs#application-notes-and-protocols-for-nsc636819\]](#)

Disclaimer & Data Validity:

The information provided in this document is for Research Use Only (RUO) and is strictly not intended for diagnostic or therapeutic procedures. While BenchChem strives to provide accurate protocols, we make no warranties, express or implied, regarding the fitness of this product for every specific experimental setup.

Technical Support: The protocols provided are for reference purposes. Unsure if this reagent suits your experiment?

Need Industrial/Bulk Grade? [Request Custom Synthesis Quote](#)

BenchChem

Our mission is to be the trusted global source of essential and advanced chemicals, empowering scientists and researchers to drive progress in science and industry.

Contact

Address: 3281 E Guasti Rd
Ontario, CA 91761, United States
Phone: (601) 213-4426
Email: info@benchchem.com

[Contact our Ph.D. Support Team for a compatibility check](#)