

Validating LSD1 Inhibition: A Comparative Guide to Namoline and siRNA

Author: BenchChem Technical Support Team. **Date:** April 2026

Compound of Interest

Compound Name: *Namoline*
Cat. No.: *B15588836*

[Get Quote](#)

For Researchers, Scientists, and Drug Development Professionals

This guide provides an objective comparison of two key methods for validating the function of Lysine-Specific Demethylase 1 (LSD1), a critical epigenetic regulator and a promising therapeutic target in oncology. We will compare the effects of **Namoline**, a selective and reversible chemical inhibitor, with the genetic knockdown of LSD1 using small interfering RNA (siRNA). This guide presents supporting experimental data, detailed protocols for essential validation assays, and visualizations of the underlying biological pathways and experimental workflows to aid researchers in designing robust experiments for target validation.

Mechanism of Action: Chemical Inhibition vs. Genetic Knockdown

Understanding the distinct mechanisms of **Namoline** and siRNA is crucial for interpreting experimental outcomes.

- **Namoline:** This γ -pyrone compound acts as a selective and reversible inhibitor of LSD1.^[1] It functions by competing with the histone substrate for the active site of the LSD1 enzyme,

thereby preventing the demethylation of its primary targets, H3K4me1/2 and H3K9me1/2.[1] Its reversible nature allows for the study of the acute effects of LSD1 inhibition.[1]

- siRNA Knockdown: This genetic tool operates through the RNA interference (RNAi) pathway. A synthetic siRNA duplex, complementary to the LSD1 mRNA, is introduced into cells, leading to the specific degradation of the LSD1 transcript.[1] This prevents the synthesis of new LSD1 protein, resulting in a potent and specific reduction in the total cellular levels of the enzyme.[1]

Head-to-Head Comparison: Namoline vs. LSD1 siRNA

The core principle of validating an inhibitor like **Namoline** is to demonstrate that its biological effects phenocopy those observed with genetic knockdown of the target protein, LSD1. Both methods effectively counteract LSD1's function, leading to similar downstream cellular effects such as the re-expression of silenced genes and inhibition of cell proliferation.[1]

Quantitative Data Presentation

The following tables summarize the comparative effects of **Namoline** and LSD1 siRNA based on preclinical data.

Table 1: Impact on LSD1 Levels and Histone Marks

Parameter	Namoline	siRNA Knockdown of LSD1
LSD1 Protein Level	No direct effect on protein expression level	~85% decrease in protein levels
LSD1 Enzymatic Activity	Directly inhibited	Indirectly reduced due to lower protein levels
Global H3K4me2 Levels	Increased	Increased
Global H3K9me2 Levels	Increased	Increased

Table 2: Downstream Cellular and Gene Expression Effects

Parameter	Namoline	siRNA Knockdown of LSD1
Target Gene Expression	Induces expression of epigenetically suppressed genes (e.g., SFRP1, SFRP4, SFRP5, GATA5)	Induces re-expression of silenced genes
Cell Proliferation	Reduces androgen-induced proliferation of LNCaP cells	64% decrease in BrdU labeling in neural stem cells[2]
Cell Cycle	Can cause proliferation arrest	Can induce G2/M phase cell cycle arrest in neuroblastoma cells
Reversibility/Duration	Reversible; effects diminish upon compound removal	Transient; effects typically last 48-72 hours until the siRNA is diluted or degraded

Signaling Pathways and Experimental Workflows

Visualizing the biological context and experimental processes is crucial for understanding the action and evaluation of these inhibitory methods.

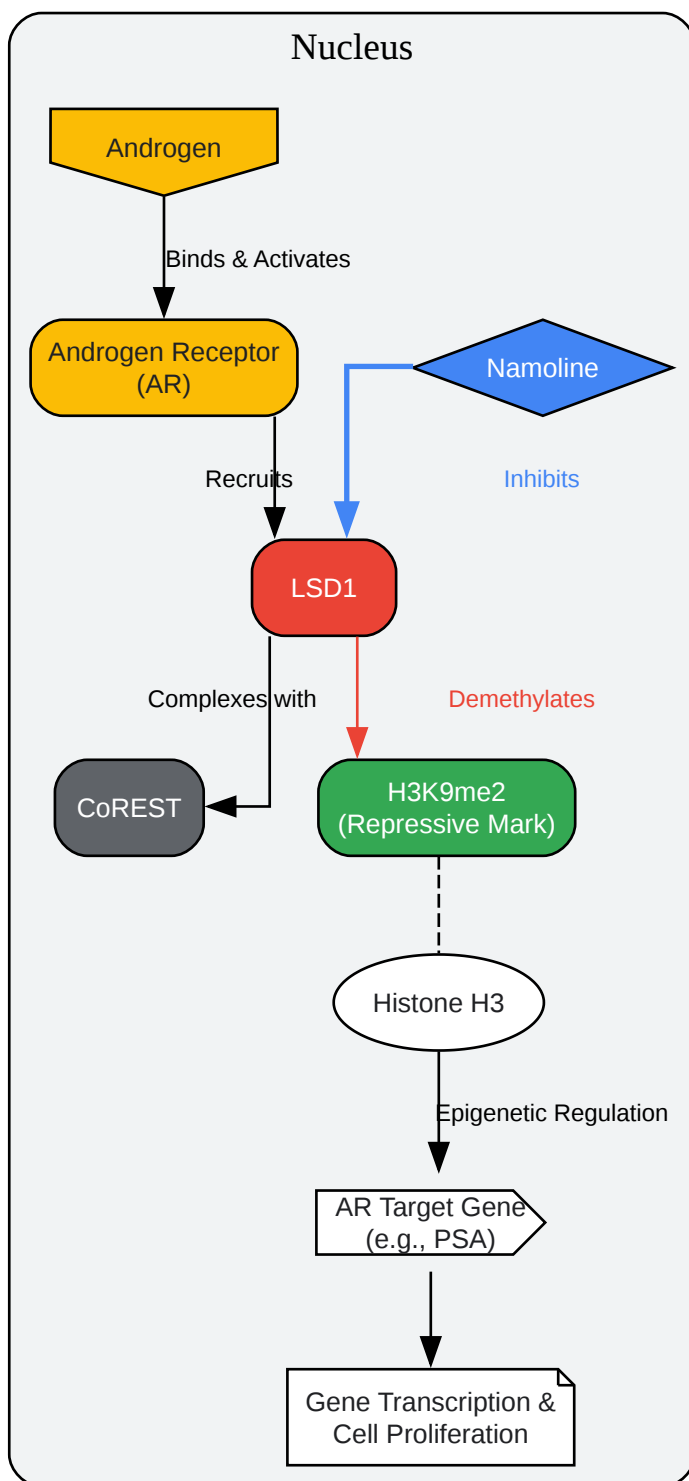

[Click to download full resolution via product page](#)

Caption: LSD1's role in the Androgen Receptor signaling pathway and the point of intervention by **Namoline**.

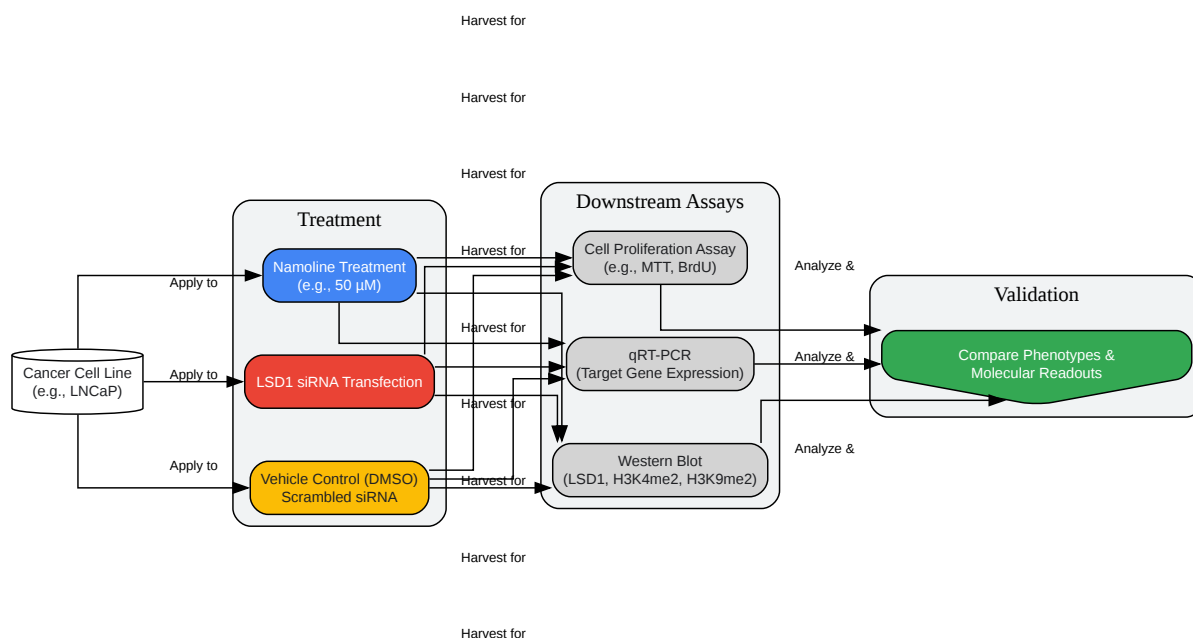

[Click to download full resolution via product page](#)

Caption: Experimental workflow for validating **Namoline's** on-target effects by comparison with LSD1 siRNA.

Experimental Protocols

Detailed methodologies for the key experiments cited in this guide are provided below.

LSD1 Knockdown using siRNA

This protocol provides a general guideline for the transient transfection of mammalian cells (e.g., LNCaP) with siRNA.

Materials:

- LSD1-specific siRNA duplexes (validated sequences recommended)
- Non-targeting (scrambled) siRNA control
- siRNA Transfection Reagent (e.g., Lipofectamine™ RNAiMAX)
- Serum-free medium (e.g., Opti-MEM™)
- 6-well tissue culture plates
- Antibiotic-free normal growth medium

Procedure:

- Cell Seeding: The day before transfection, seed 2×10^5 cells per well in a 6-well plate with 2 mL of antibiotic-free normal growth medium. Ensure cells are 60-80% confluent on the day of transfection.
- siRNA-Lipid Complex Formation:
 - Solution A: For each well, dilute 20-80 pmols of LSD1 siRNA or scrambled control siRNA into 100 μ L of siRNA Transfection Medium.
 - Solution B: For each well, dilute 2-8 μ L of siRNA Transfection Reagent into 100 μ L of siRNA Transfection Medium.
 - Combine Solution A and Solution B. Mix gently by pipetting and incubate for 15-45 minutes at room temperature.
- Transfection:
 - Wash the cells once with 2 mL of siRNA Transfection Medium.
 - Add 0.8 mL of siRNA Transfection Medium to each tube containing the siRNA-lipid complex.

- Aspirate the wash medium from the cells and overlay the 1 mL siRNA-lipid complex mixture onto the cells.
- Incubation:
 - Incubate the cells for 4-6 hours at 37°C in a CO2 incubator.
 - Add 1 mL of 2x normal growth medium (containing serum and antibiotics).
 - Incubate for an additional 24-72 hours before harvesting for downstream analysis.
- Validation of Knockdown: The efficiency of LSD1 knockdown should be confirmed by Western blot or qRT-PCR.

Namoline Treatment of Cultured Cells

This protocol outlines the treatment of cultured cells with **Namoline**.

Materials:

- **Namoline** (stock solution typically dissolved in DMSO)
- Complete growth medium
- Cultured cells of interest (e.g., LNCaP)

Procedure:

- Cell Seeding: Seed cells in the desired plate format (e.g., 6-well, 96-well) and allow them to adhere and reach 70-80% confluency.
- Compound Dilution: Prepare a working solution of **Namoline** by diluting the stock solution in complete growth medium to the desired final concentration (e.g., 50 μ M). Prepare a vehicle control (e.g., DMSO) at the same final concentration.
- Treatment: Remove the existing medium from the cells and replace it with the medium containing **Namoline** or the vehicle control.
- Incubation: Incubate the cells for the desired duration (e.g., 24, 48, or 72 hours).

- Analysis: Following incubation, harvest the cells for downstream analysis such as Western blotting, qRT-PCR, or cell viability assays.

Western Blot for LSD1 and Histone Methylation

This assay determines the effect of **Namoline** or siRNA on the levels of LSD1 and its histone substrates, H3K4me2 and H3K9me2.

Materials:

- Treated and control cell pellets
- RIPA buffer with protease and phosphatase inhibitors
- Acid extraction buffer (for histones)
- BCA or Bradford assay reagents
- SDS-PAGE gels and running buffer
- PVDF or nitrocellulose membranes
- Blocking buffer (5% non-fat milk or BSA in TBST)
- Primary antibodies: anti-LSD1, anti-H3K4me2, anti-H3K9me2, anti-total Histone H3 (loading control)
- HRP-conjugated secondary antibody
- Enhanced chemiluminescence (ECL) substrate

Procedure:

- Cell Lysis:
 - For total protein: Lyse cells in RIPA buffer.
 - For histones: Perform an acid extraction of histones from the nuclear fraction.

- **Protein Quantification:** Determine the protein concentration of the lysates using a BCA or Bradford assay.
- **SDS-PAGE:** Load 10-20 µg of protein per lane onto an SDS-polyacrylamide gel and separate by electrophoresis.
- **Transfer:** Transfer the separated proteins to a PVDF or nitrocellulose membrane.
- **Blocking:** Block the membrane for 1 hour at room temperature in blocking buffer.
- **Primary Antibody Incubation:** Incubate the membrane with primary antibodies overnight at 4°C.
- **Secondary Antibody Incubation:** Wash the membrane with TBST and incubate with the appropriate HRP-conjugated secondary antibody for 1 hour at room temperature.
- **Detection:** Wash the membrane again, apply ECL substrate, and visualize the bands using an imaging system.
- **Analysis:** Quantify the band intensities using densitometry software. Normalize the levels of LSD1 and histone marks to the loading control.

Conclusion

Both **Namoline** and siRNA are powerful tools for investigating LSD1 function. **Namoline** offers a reversible, rapid method to probe the consequences of inhibiting LSD1's catalytic activity, which is more analogous to a potential therapeutic intervention.^[1] In contrast, siRNA provides a highly specific genetic approach to deplete the LSD1 protein, confirming that the observed phenotype is a direct result of the protein's absence.^[1] For comprehensive and robust target validation, a dual approach using both a chemical inhibitor like **Namoline** and a genetic tool like siRNA is the gold standard. The convergence of results from both methodologies provides the strongest evidence for the biological role of LSD1 and the on-target activity of the inhibitor.^[1]

Need Custom Synthesis?

BenchChem offers custom synthesis for rare earth carbides and specific isotopic labeling.

Email: info@benchchem.com or [Request Quote Online](#).

References

- [1. benchchem.com \[benchchem.com\]](#)
- [2. Histone Demethylase LSD1 Regulates Neural Stem Cell Proliferation - PMC \[pmc.ncbi.nlm.nih.gov\]](#)
- To cite this document: BenchChem. [Validating LSD1 Inhibition: A Comparative Guide to Namoline and siRNA]. BenchChem, [2026]. [Online PDF]. Available at: [\[https://www.benchchem.com/product/b15588836/docs#validating-lsd1-inhibition-a-comparative-guide-to-namoline-and-sirna\]](https://www.benchchem.com/product/b15588836/docs#validating-lsd1-inhibition-a-comparative-guide-to-namoline-and-sirna)

Disclaimer & Data Validity:

The information provided in this document is for Research Use Only (RUO) and is strictly not intended for diagnostic or therapeutic procedures. While BenchChem strives to provide accurate protocols, we make no warranties, express or implied, regarding the fitness of this product for every specific experimental setup.

Technical Support: The protocols provided are for reference purposes. Unsure if this reagent suits your experiment?

Need Industrial/Bulk Grade? [Request Custom Synthesis Quote](#)

BenchChem

Our mission is to be the trusted global source of essential and advanced chemicals, empowering scientists and researchers to drive progress in science and industry.

Contact

Address: 3281 E Guasti Rd

Ontario, CA 91761, United States

Phone: (601) 213-4426

Email: info@benchchem.com

Contact our Ph.D. Support Team for a compatibility check