

Technical Support Center: ZM226600 Delivery Methods

Author: BenchChem Technical Support Team. **Date:** April 2026

Compound of Interest

Compound Name:	ZM226600
CAS No.:	5326-71-6
Cat. No.:	B15588317

[Get Quote](#)

This technical support center provides researchers, scientists, and drug development professionals with comprehensive guidance on the effective delivery of **ZM226600**. This resource offers troubleshooting guides, frequently asked questions (FAQs), detailed experimental protocols, and visual aids to facilitate successful experimentation.

Troubleshooting Guide

This guide addresses common issues encountered during the preparation and application of **ZM226600** in a question-and-answer format.

Issue	Possible Cause	Recommended Solution
Precipitation of ZM226600 in aqueous solutions.	ZM226600 has low water solubility. Direct dilution of a concentrated DMSO stock into aqueous media can cause the compound to crash out of solution.	<ol style="list-style-type: none">1. Optimize Final DMSO Concentration: Most cell lines can tolerate a final DMSO concentration of 0.1% to 0.5% without significant cytotoxicity. [1] Prepare a higher concentration stock solution in 100% DMSO. Add the small volume of the stock solution directly to the cell culture medium while vortexing or stirring to ensure rapid and even dispersion.2. Use a Co-solvent: Consider using a water-miscible organic co-solvent in your final formulation.3. Serial Dilutions in DMSO: If preparing a dose-response curve, perform serial dilutions in 100% DMSO before the final dilution into the aqueous medium.[2]
Inconsistent or unexpected experimental results.	<ol style="list-style-type: none">1. Compound Degradation: Improper storage can lead to the degradation of ZM226600.2. Inaccurate Concentration: Precipitation or adsorption to plasticware can lead to a lower effective concentration.3. Cell Line Variability: Different cell lines may exhibit varying sensitivity to DMSO and ZM226600.	<ol style="list-style-type: none">1. Proper Storage: Store the solid compound and stock solutions as recommended by the manufacturer, typically at -20°C or -80°C for long-term stability. Avoid repeated freeze-thaw cycles.2. Pre-dissolve Completely: Ensure the compound is fully dissolved in DMSO before any dilution steps. Sonication can aid in dissolving the compound.3. Control

Experiments: Always include a vehicle control (medium with the same final concentration of DMSO) to account for any effects of the solvent on the cells.[3]

Cell toxicity or death observed after treatment.

The final concentration of DMSO may be too high for the specific cell line being used. Primary cells are often more sensitive than immortalized cell lines.

1. Determine DMSO Tolerance: Perform a dose-response experiment with varying concentrations of DMSO (e.g., 0.05% to 1%) to determine the maximum tolerable concentration for your specific cell line. 2. Minimize DMSO Volume: Prepare a more concentrated stock solution of ZM226600 in DMSO to minimize the volume added to the cell culture, thereby lowering the final DMSO concentration.

Frequently Asked Questions (FAQs)

Q1: What is the mechanism of action of **ZM226600**?

A1: **ZM226600** is a potent ATP-sensitive potassium (K-ATP) channel opener.[4] K-ATP channels are hetero-octameric protein complexes composed of four pore-forming inwardly rectifying potassium channel (Kir6.x) subunits and four regulatory sulfonylurea receptor (SUR) subunits.[4][5] These channels couple the metabolic state of a cell to its electrical activity.[4][5] **ZM226600**, a tertiary carbinol, acts by binding to the SUR subunit, which antagonizes the inhibitory effect of ATP on the Kir6.x pore.[5][6] This leads to the opening of the K-ATP channel, resulting in potassium ion efflux and hyperpolarization of the cell membrane.

Q2: What are the downstream effects of opening K-ATP channels with **ZM226600**?

A2: The downstream effects of **ZM226600**-mediated K-ATP channel opening are tissue-specific:

- In Pancreatic β -cells: Opening of K-ATP channels leads to membrane hyperpolarization, which prevents the opening of voltage-gated calcium channels.[7] This inhibits calcium influx and subsequently reduces insulin secretion.[7][8]
- In Smooth Muscle Cells (e.g., vascular): Membrane hyperpolarization leads to the closure of voltage-dependent calcium channels, reducing intracellular calcium concentration and causing muscle relaxation (vasodilation).[9][10][11]
- In Neurons: Opening of K-ATP channels can suppress neuronal excitability by hyperpolarizing the cell membrane, moving it further from the threshold for action potential firing.[12] This can have neuroprotective effects in conditions like ischemia.[12]

Q3: What is the solubility of **ZM226600**?

A3: **ZM226600** has low aqueous solubility but is highly soluble in dimethyl sulfoxide (DMSO). The specific solubility can vary, so it is always recommended to consult the manufacturer's product data sheet.

Q4: How should I prepare a stock solution of **ZM226600**?

A4: To prepare a stock solution, dissolve **ZM226600** powder in 100% DMSO to a high concentration (e.g., 10 mM to 50 mM). Ensure the compound is completely dissolved; sonication may be used to facilitate this process. Store the stock solution in small aliquots at -20°C or -80°C to avoid repeated freeze-thaw cycles.

Q5: What are some general strategies for delivering poorly water-soluble compounds like **ZM226600** in vivo?

A5: For in vivo studies, several formulation strategies can be employed to improve the bioavailability of poorly water-soluble compounds:

- Co-solvents: A mixture of solvents, such as DMSO, polyethylene glycol (PEG), and saline, can be used to maintain solubility.

- Surfactants: The use of non-ionic surfactants can help to create stable micellar formulations.
- Lipid-based formulations: Self-emulsifying drug delivery systems (SEDDS) can improve oral absorption.
- Nanosuspensions: Reducing the particle size of the compound to the nanometer range can increase its surface area and dissolution rate.

It is crucial to perform formulation development and vehicle toxicity studies to identify a safe and effective delivery system for your specific animal model and route of administration.

Experimental Protocols

In Vitro Delivery of ZM226600 to Cultured Cells

Objective: To treat cultured cells with **ZM226600** for functional assays.

Materials:

- **ZM226600** powder
- 100% Dimethyl sulfoxide (DMSO), cell culture grade
- Complete cell culture medium appropriate for the cell line
- Sterile microcentrifuge tubes
- Vortex mixer
- Sonicator (optional)

Procedure:

- Prepare a 10 mM Stock Solution:
 - Calculate the amount of **ZM226600** powder needed to make a 10 mM stock solution in a desired volume of DMSO.
 - Aseptically weigh the **ZM226600** powder and add it to a sterile microcentrifuge tube.

- Add the calculated volume of 100% DMSO to the tube.
- Vortex thoroughly until the powder is completely dissolved. If necessary, sonicate for a few minutes to aid dissolution.
- Store the 10 mM stock solution in aliquots at -20°C or -80°C.
- Prepare Working Solutions:
 - On the day of the experiment, thaw an aliquot of the 10 mM stock solution.
 - Perform serial dilutions of the stock solution in 100% DMSO to prepare a range of working stock concentrations. This is crucial for maintaining solubility when creating a dose-response curve.
- Treating the Cells:
 - Plate the cells at the desired density and allow them to adhere or reach the desired confluency.
 - For each treatment condition, calculate the volume of the appropriate working stock solution needed to achieve the final desired concentration in the cell culture medium. The final DMSO concentration should ideally be kept below 0.5%, and consistent across all treatment groups, including the vehicle control.^[1]
 - Directly add the calculated small volume of the **ZM226600**/DMSO working solution to the pre-warmed cell culture medium. Immediately and gently swirl the plate or flask to ensure even distribution.
 - For the vehicle control, add the same volume of 100% DMSO to the cell culture medium.
 - Incubate the cells for the desired treatment duration before proceeding with your downstream assays.

Visualizations

Signaling Pathways

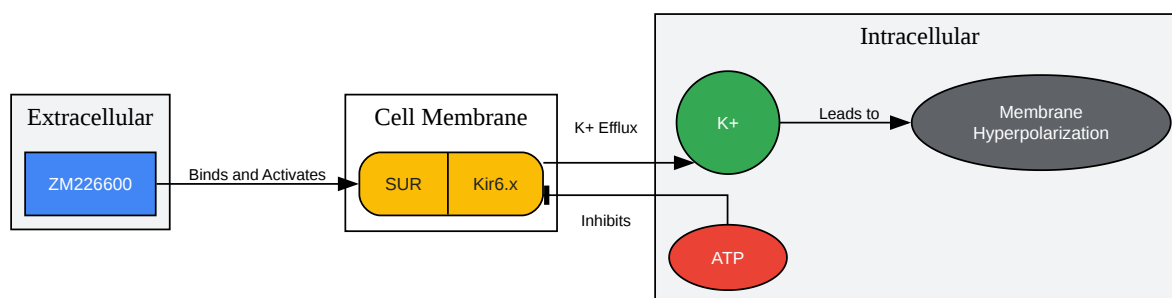

[Click to download full resolution via product page](#)

Caption: General mechanism of **ZM226600** action on K-ATP channels.

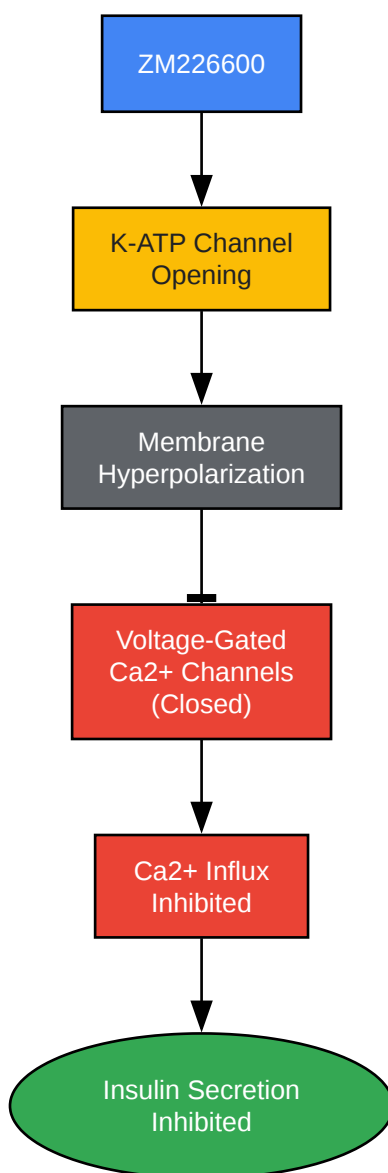

[Click to download full resolution via product page](#)

Caption: Downstream effects of **ZM226600** in pancreatic β-cells.

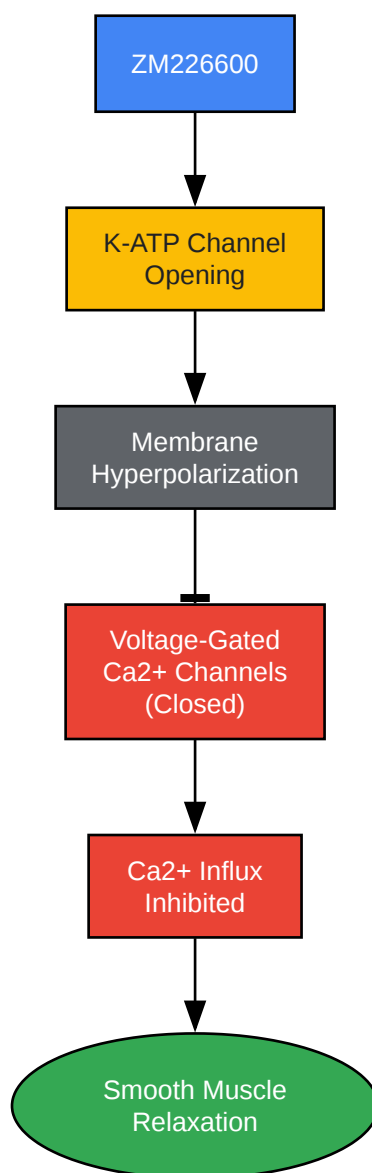

[Click to download full resolution via product page](#)

Caption: Downstream effects of **ZM226600** in smooth muscle cells.

Experimental Workflow

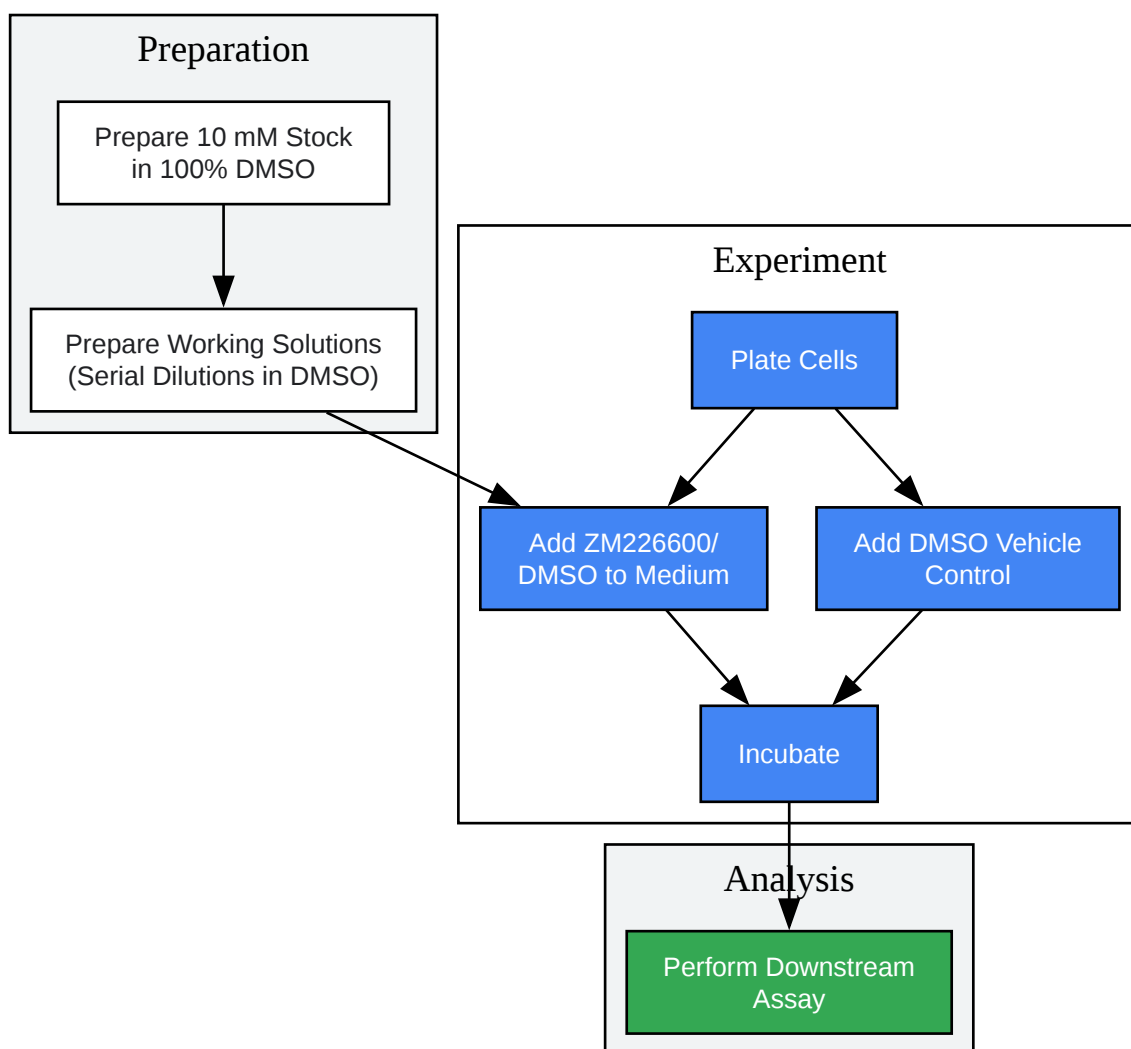

[Click to download full resolution via product page](#)

Caption: Workflow for in vitro experiments with **ZM226600**.

Need Custom Synthesis?

BenchChem offers custom synthesis for rare earth carbides and specific isotopic labeling.

Email: info@benchchem.com or [Request Quote Online](#).

References

- 1. lifetein.com [lifetein.com]

- [2. researchgate.net \[researchgate.net\]](#)
- [3. Reddit - The heart of the internet \[reddit.com\]](#)
- [4. KATP channel openers: structure-activity relationships and therapeutic potential - PubMed \[pubmed.ncbi.nlm.nih.gov\]](#)
- [5. researchgate.net \[researchgate.net\]](#)
- [6. KATP channel therapeutics at the bedside - PMC \[pmc.ncbi.nlm.nih.gov\]](#)
- [7. researchgate.net \[researchgate.net\]](#)
- [8. m.youtube.com \[m.youtube.com\]](#)
- [9. researchgate.net \[researchgate.net\]](#)
- [10. kup.at \[kup.at\]](#)
- [11. Functional roles of KATP channels in vascular smooth muscle - PubMed \[pubmed.ncbi.nlm.nih.gov\]](#)
- [12. Neuroprotective role of ATP-sensitive potassium channels in cerebral ischemia - PMC \[pmc.ncbi.nlm.nih.gov\]](#)
- To cite this document: BenchChem. [Technical Support Center: ZM226600 Delivery Methods]. BenchChem, [2026]. [Online PDF]. Available at: [\[https://www.benchchem.com/product/b15588317/docs#technical-support-center-zm226600-delivery-methods\]](https://www.benchchem.com/product/b15588317/docs#technical-support-center-zm226600-delivery-methods)

Disclaimer & Data Validity:

The information provided in this document is for Research Use Only (RUO) and is strictly not intended for diagnostic or therapeutic procedures. While BenchChem strives to provide accurate protocols, we make no warranties, express or implied, regarding the fitness of this product for every specific experimental setup.

Technical Support: The protocols provided are for reference purposes. Unsure if this reagent suits your experiment?

Need Industrial/Bulk Grade? [Request Custom Synthesis Quote](#)

BenchChem

Our mission is to be the trusted global source of essential and advanced chemicals, empowering scientists and researchers to drive progress in science and industry.

Contact

Address: 3281 E Guasti Rd

Ontario, CA 91761, United States

Phone: (601) 213-4426

Email: info@benchchem.com

[Contact our Ph.D. Support Team for a compatibility check](#)