

Application Notes for Prmt5-IN-39 in Immunoprecipitation Experiments

Author: BenchChem Technical Support Team. **Date:** April 2026

Compound of Interest

Compound Name: Prmt5-IN-39

Cat. No.: B15588372

[Get Quote](#)

For Researchers, Scientists, and Drug Development Professionals

Introduction to PRMT5 and the Role of Immunoprecipitation

Protein Arginine Methyltransferase 5 (PRMT5) is a critical enzyme that catalyzes the symmetric dimethylation of arginine residues on both histone and non-histone proteins.[1][2] This post-translational modification is pivotal in a wide array of cellular processes, including transcriptional regulation, RNA splicing, signal transduction, and DNA damage response.[1][2][3] Dysregulation of PRMT5 activity is implicated in various diseases, particularly cancer, making it a significant therapeutic target.[4][5][6]

Immunoprecipitation (IP) is a powerful technique used to isolate a specific protein and its binding partners from a complex mixture, such as a cell lysate. When combined with the use of a specific inhibitor like **Prmt5-IN-39**, IP can provide invaluable insights into how the enzymatic activity of PRMT5 influences its protein-protein interactions. This allows researchers to understand the inhibitor's mechanism of action and to identify novel protein interactions that are dependent on PRMT5's catalytic function.

Mechanism of Action of PRMT5 Inhibitors in the Context of IP

Prmt5-IN-39, as a putative inhibitor of PRMT5, is expected to block the methyltransferase activity of the enzyme. This inhibition can alter the interaction landscape of PRMT5. Some interacting proteins may only bind to PRMT5 when it is catalytically active, while others might be recruited to the PRMT5 complex upon inhibition. By performing immunoprecipitation of PRMT5 in the presence and absence of **Prmt5-IN-39**, researchers can identify changes in the composition of the PRMT5 interactome, revealing proteins whose association is dependent on PRMT5's enzymatic activity.

Quantitative Data Summary

While specific quantitative data for **Prmt5-IN-39** is not available in the public domain, the following table provides a general reference for concentrations and conditions used for other PRMT5 inhibitors in cellular assays, which can serve as a starting point for optimizing experiments with **Prmt5-IN-39**.

Parameter	Typical Range/Value	Source
Inhibitor Concentration	1 - 10 μ M	General practice for cell-based assays
Treatment Duration	24 - 72 hours	[7]
Antibody for IP	2 - 10 μ g per IP reaction	[7][8][9]
Protein Lysate Amount	1 - 5 mg per IP reaction	[9]
Bead Type	Protein A/G magnetic beads	[7][8][10]

PRMT5 Signaling Pathways

PRMT5 is a key regulator in multiple signaling pathways that are crucial for cell proliferation, survival, and differentiation.[3][4] Understanding these pathways is essential for contextualizing the effects of PRMT5 inhibition.

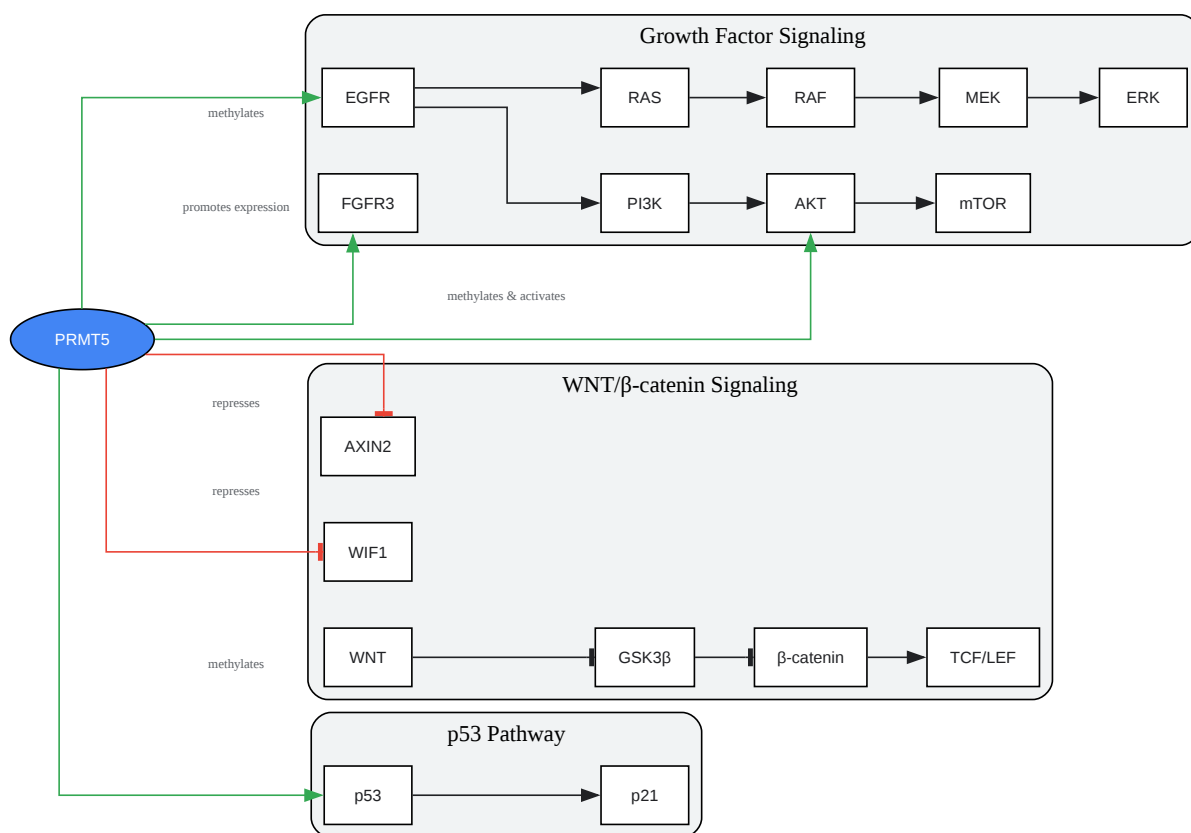

[Click to download full resolution via product page](#)

Caption: PRMT5 interacts with and modulates key signaling pathways involved in cancer, including growth factor, WNT/β-catenin, and p53 pathways.

Experimental Protocol: Immunoprecipitation of PRMT5

This protocol details the steps for immunoprecipitating PRMT5 from cultured mammalian cells treated with **Prmt5-IN-39** to identify interaction partners sensitive to its enzymatic activity.

Materials

- Cultured mammalian cells
- **Prmt5-IN-39** (and appropriate solvent, e.g., DMSO)
- Phosphate-buffered saline (PBS), ice-cold
- Lysis Buffer (e.g., RIPA buffer supplemented with protease and phosphatase inhibitors)
- Anti-PRMT5 antibody
- Isotype control IgG
- Protein A/G magnetic beads
- Wash Buffer (e.g., lysis buffer diluted 1:1 with PBS)
- Elution Buffer (e.g., 0.1 M glycine, pH 2.5 or 2x Laemmli sample buffer)
- Neutralization Buffer (e.g., 1 M Tris, pH 8.5)

Experimental Workflow

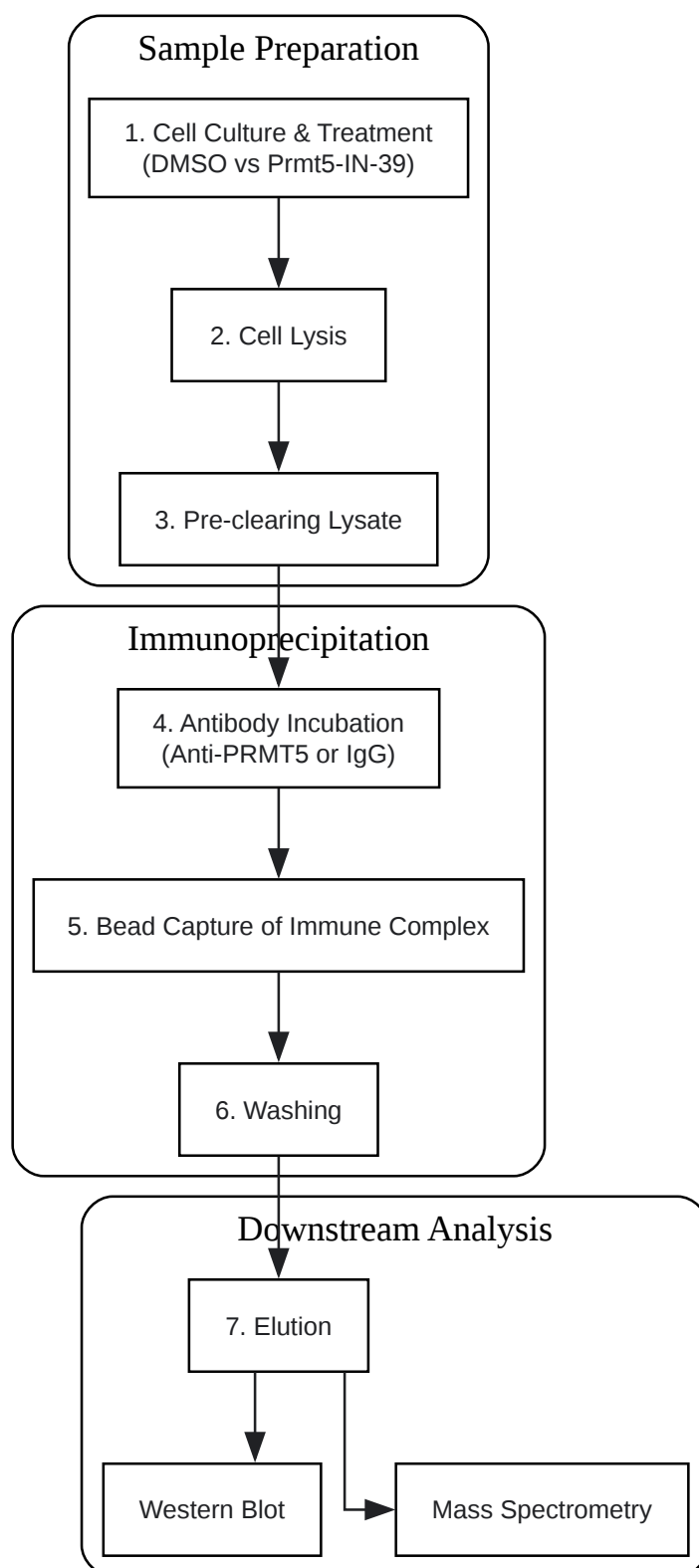

[Click to download full resolution via product page](#)

Caption: Workflow for PRMT5 immunoprecipitation following treatment with **Prmt5-IN-39**.

Procedure

- Cell Culture and Treatment:
 - Plate cells to achieve 70-80% confluency.
 - Treat cells with the desired concentration of **Prmt5-IN-39** or an equivalent volume of vehicle control (e.g., DMSO).
 - Incubate for a predetermined time (e.g., 24-72 hours).[7]
- Cell Lysis:
 - Wash cells twice with ice-cold PBS.
 - Add ice-cold lysis buffer, incubate on ice for 30 minutes with occasional vortexing.[10]
 - Scrape cells and transfer the lysate to a pre-chilled microcentrifuge tube.
 - Centrifuge at 14,000 x g for 15 minutes at 4°C to pellet cellular debris.[10]
 - Transfer the supernatant (protein lysate) to a new tube.
- Protein Quantification and Normalization:
 - Determine the protein concentration of each lysate (e.g., using a BCA assay).
 - Normalize all samples to the same protein concentration by diluting with lysis buffer.
- Pre-clearing the Lysate:
 - To reduce non-specific binding, add equilibrated protein A/G magnetic beads to the lysate and incubate with rotation for 1 hour at 4°C.[10]
 - Place the tube on a magnetic rack and collect the pre-cleared lysate.
- Immunoprecipitation:

- To the pre-cleared lysate, add 2-10 µg of anti-PRMT5 antibody or isotype control IgG.[7][8][9]
- Incubate with gentle rotation for 4 hours to overnight at 4°C.[7][8][10]
- Add equilibrated protein A/G magnetic beads to the lysate-antibody mixture and incubate for an additional 1-2 hours at 4°C.[7][10]
- Washing:
 - Pellet the beads using a magnetic rack and discard the supernatant.
 - Wash the beads 3-5 times with ice-cold wash buffer.
- Elution:
 - For Western Blot Analysis: Add 2x Laemmli sample buffer to the beads and boil at 95-100°C for 5-10 minutes.[10]
 - For Mass Spectrometry Analysis: Add elution buffer (e.g., 0.1 M glycine, pH 2.5), incubate for 5-10 minutes, collect the eluate, and immediately neutralize it.[10]
- Downstream Analysis:
 - Western Blot: Analyze the eluates by SDS-PAGE and Western blotting to confirm the pulldown of PRMT5 and to detect co-precipitated proteins.
 - Mass Spectrometry: Process the eluates for mass spectrometry to identify the full spectrum of interacting proteins and compare the interactomes of DMSO vs. **Prmt5-IN-39** treated samples.

Need Custom Synthesis?

BenchChem offers custom synthesis for rare earth carbides and specific isotopic labeling.

Email: info@benchchem.com or [Request Quote Online](#).

References

- [1. The Structure and Functions of PRMT5 in Human Diseases - PMC \[pmc.ncbi.nlm.nih.gov\]](#)
- [2. discovery.researcher.life \[discovery.researcher.life\]](#)
- [3. PRMT5 function and targeting in cancer \[cell-stress.com\]](#)
- [4. aacrjournals.org \[aacrjournals.org\]](#)
- [5. Protein arginine methyltransferase 5 functions as an epigenetic activator of the androgen receptor to promote prostate cancer cell growth - PMC \[pmc.ncbi.nlm.nih.gov\]](#)
- [6. onclive.com \[onclive.com\]](#)
- [7. benchchem.com \[benchchem.com\]](#)
- [8. Protein arginine methyltransferase 5 \(Prmt5\) localizes to chromatin loop anchors and modulates expression of genes at TAD boundaries during early adipogenesis - PMC \[pmc.ncbi.nlm.nih.gov\]](#)
- [9. Frontiers | PRMT5 Interacting Partners and Substrates in Oligodendrocyte Lineage Cells \[frontiersin.org\]](#)
- [10. benchchem.com \[benchchem.com\]](#)
- To cite this document: BenchChem. [Application Notes for Prmt5-IN-39 in Immunoprecipitation Experiments]. BenchChem, [2026]. [Online PDF]. Available at: [<https://www.benchchem.com/product/b15588372/docs#application-notes-for-prmt5-in-39-in-immunoprecipitation-experiments>]

Disclaimer & Data Validity:

The information provided in this document is for Research Use Only (RUO) and is strictly not intended for diagnostic or therapeutic procedures. While BenchChem strives to provide accurate protocols, we make no warranties, express or implied, regarding the fitness of this product for every specific experimental setup.

Technical Support: The protocols provided are for reference purposes. Unsure if this reagent suits your experiment?

Need Industrial/Bulk Grade? [Request Custom Synthesis Quote](#)

BenchChem

Our mission is to be the trusted global source of essential and advanced chemicals, empowering scientists and researchers to drive progress in science and industry.

Contact

Address: 3281 E Guasti Rd
Ontario, CA 91761, United States
Phone: (601) 213-4426
Email: info@benchchem.com

[Contact our Ph.D. Support Team for a compatibility check](#)