

# Application Notes and Protocols for Utilizing UNC6934 in a NanoBRET™ Assay

**Author:** BenchChem Technical Support Team. **Date:** April 2026

## Compound of Interest

Compound Name: *UNC6934*

Cat. No.: *B15588771*

[Get Quote](#)

For Researchers, Scientists, and Drug Development Professionals

## Introduction

**UNC6934** is a potent and selective chemical probe that targets the N-terminal Pro-Pro-Trp-Pro (PWWP) domain of Nuclear Receptor Binding SET Domain Protein 2 (NSD2), also known as MMSET or WHSC1.[1][2] NSD2 is a histone methyltransferase responsible for the dimethylation of histone H3 at lysine 36 (H3K36me2), a mark associated with active gene transcription.[1][3] By binding to the aromatic cage of the NSD2 PWWP1 domain, **UNC6934** effectively antagonizes its interaction with H3K36me2-containing nucleosomes.[1][4] This disruption of a critical protein-protein interaction (PPI) within the cell nucleus makes **UNC6934** a valuable tool for studying the biological functions of NSD2 and for potential therapeutic development.

The NanoBRET™ (Bioluminescence Resonance Energy Transfer) technology offers a sensitive and quantitative method to measure protein-protein interactions or compound engagement with a target protein in live cells.[5][6] This technology utilizes a NanoLuc® luciferase as the energy donor and a fluorescently labeled HaloTag® protein as the energy acceptor.[7] When these two

components are in close proximity (<10 nm), energy transfer occurs, resulting in a detectable fluorescent signal.[5]

This document provides detailed application notes and protocols for utilizing **UNC6934** in a NanoBRET™ Protein-Protein Interaction (PPI) assay to measure its engagement with the NSD2 PWWP1 domain in a cellular context.

## Signaling Pathway of NSD2 and UNC6934's Mechanism of Action

NSD2 plays a crucial role in chromatin regulation. Its PWWP1 domain recognizes and binds to the H3K36me2 mark on nucleosomes, which is essential for its proper localization and enzymatic activity. **UNC6934** acts as a competitive antagonist, binding to the PWWP1 domain and preventing its interaction with the histone tail. This leads to the delocalization of NSD2 from chromatin.[1][4]

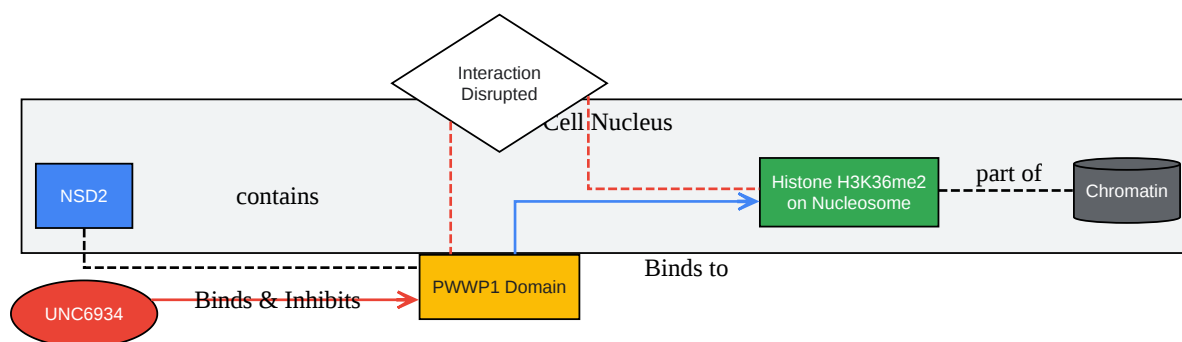

[Click to download full resolution via product page](#)

Caption: **UNC6934** mechanism of action on the NSD2 pathway.

## Quantitative Data Summary

The following tables summarize the key quantitative data for **UNC6934** and its application in the NanoBRET™ assay.

Table 1: **UNC6934** Potency and Binding Affinity

Parameter	Value	Method	Reference
IC50 (NanoBRET™)	1.09 μM	U2OS cells	[8]
EC50 (NanoBRET™)	1.23 ± 0.25 μM	U2OS cells	[1]
Kd (SPR)	80 nM	In vitro	[8]

Table 2: **UNC6934** Selectivity

Target Domain	Selectivity vs. NSD2-PWWP1	Method	Reference
14 other PWWP domains	Selective for NSD2-PWWP1	Differential Scanning Fluorimetry (DSF)	[8]
NSD3-PWWP1	Selective for NSD2-PWWP1	Differential Scanning Fluorimetry (DSF)	[2]
33 methyltransferase domains	No inhibition observed	In vitro enzyme assays	[9]

Table 3: Negative Control Compound

Compound	Activity in NanoBRET™	Reference
UNC7145	Inactive	[2]

## Experimental Protocols

This section details the protocol for a NanoBRET™ PPI assay to measure the displacement of a HaloTag®-Histone H3.3 fusion protein from a NanoLuc®-NSD2-PWWP1 fusion protein by **UNC6934** in live cells. This protocol is adapted from standard Promega NanoBRET™ PPI protocols and specific literature on **UNC6934**.[\[1\]](#)[\[7\]](#)

## Materials and Reagents

- Cells: U2OS (human bone osteosarcoma) cells are recommended as they have been used in published studies.[8] HEK293 cells are also a suitable alternative.
- Plasmids:
  - NanoLuc®-NSD2-PWWP1 fusion vector (as the BRET donor)
  - HaloTag®-Histone H3.3 fusion vector (as the BRET acceptor)
- Transfection Reagent: FuGENE® HD Transfection Reagent or similar.
- Culture Medium: DMEM or MEM supplemented with 10% Fetal Bovine Serum (FBS).
- Assay Plate: White, 96-well or 384-well, flat-bottom, tissue culture-treated plates.
- **UNC6934**: Prepare a stock solution in DMSO (e.g., 10 mM). Selleck Chemicals reports a solubility of 22 mg/mL (49.6 mM) in fresh DMSO.[10]
- UNC7145 (Negative Control): Prepare a stock solution in DMSO at the same concentration as **UNC6934**.
- NanoBRET™ Nano-Glo® Detection System:
  - HaloTag® NanoBRET® 618 Ligand
  - NanoBRET® Nano-Glo® Substrate
- Opti-MEM® I Reduced Serum Medium
- Luminometer: A plate reader capable of measuring dual-filtered luminescence with filters for NanoLuc® emission (460nm) and HaloTag® 618 Ligand emission (618nm).

## Experimental Workflow Diagram

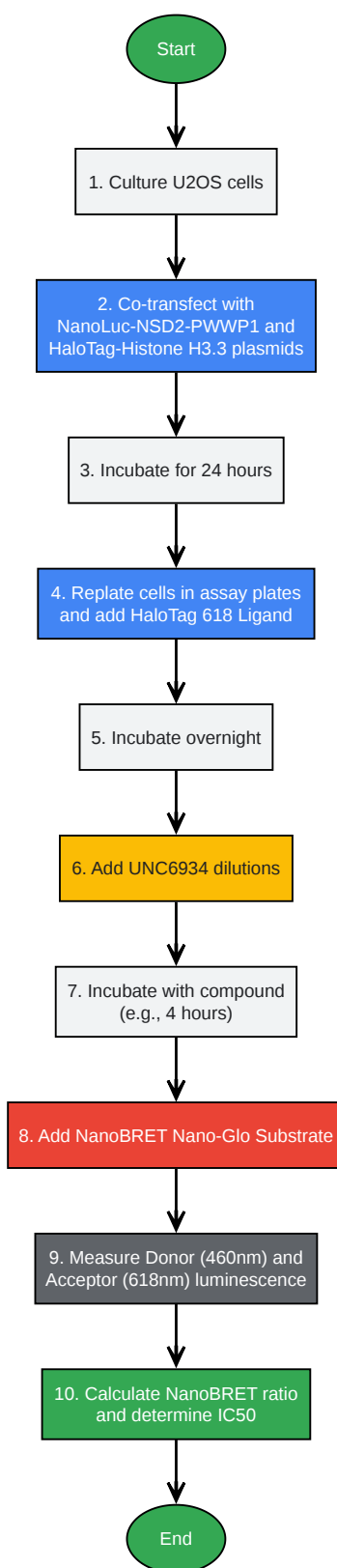

[Click to download full resolution via product page](#)

Caption: Step-by-step workflow for the **UNC6934** NanoBRET assay.

## Detailed Protocol

### Day 1: Cell Plating for Transfection

- Culture U2OS cells in a T75 flask to ~70-80% confluency.
- Trypsinize and resuspend the cells in fresh culture medium.
- Plate the cells in a 6-well plate at a density that will result in 70-90% confluency on the day of transfection.

### Day 2: Transfection

- Prepare the transfection complexes in Opti-MEM®. For each well of a 6-well plate, a ratio of 1:10 (Donor:Acceptor plasmid) is a good starting point (e.g., 0.1 µg NanoLuc®-NSD2-PWWP1 and 1.0 µg HaloTag®-Histone H3.3).
- Add the transfection reagent according to the manufacturer's instructions.
- Incubate the complexes at room temperature for 10-20 minutes.
- Add the transfection complexes dropwise to the cells.
- Incubate the cells for 24 hours at 37°C in a 5% CO2 incubator.

### Day 3: Cell Plating for Assay

- Trypsinize the transfected cells and resuspend them in fresh culture medium.
- Dilute the cells to a concentration of  $2 \times 10^5$  cells/mL.
- Prepare two pools of cells:
  - Experimental Wells: Add HaloTag® NanoBRET® 618 Ligand to the cell suspension at a final concentration of 100 nM.
  - No-Ligand Control Wells: Add an equivalent volume of DMSO to the cell suspension.
- Dispense 100 µL of the cell suspension into the wells of a white 96-well assay plate.

- Incubate the plate overnight at 37°C in a 5% CO<sub>2</sub> incubator.

#### Day 4: Compound Treatment and Data Acquisition

- Prepare serial dilutions of **UNC6934** and the negative control UNC7145 in Opti-MEM®. A typical concentration range to test would be from 0.01 µM to 30 µM.
- Carefully remove the culture medium from the wells and add the compound dilutions.
- Incubate the plate for the desired time (e.g., 4 hours) at 37°C in a 5% CO<sub>2</sub> incubator.[8]
- Prepare the NanoBRET® Nano-Glo® Substrate according to the manufacturer's protocol (typically a 1:100 dilution of substrate in the provided buffer).
- Add 25 µL of the prepared substrate to each well.
- Incubate the plate at room temperature for 3-5 minutes to allow the signal to stabilize.
- Measure the luminescence using a plate reader with the following filter settings:
  - Donor Emission: 460nm (bandpass filter)
  - Acceptor Emission: 618nm (longpass filter)

## Data Analysis

- Calculate the Raw NanoBRET™ Ratio:
  - For each well, divide the acceptor emission value (618nm) by the donor emission value (460nm).
- Calculate the Corrected NanoBRET™ Ratio:
  - Subtract the average Raw NanoBRET™ Ratio of the "No-Ligand Control" wells from the Raw NanoBRET™ Ratio of each experimental well.
- Normalize the Data:

- Set the average Corrected NanoBRET™ Ratio of the DMSO-treated wells (vehicle control) to 100%.
- Express the Corrected NanoBRET™ Ratios of the **UNC6934**-treated wells as a percentage of the vehicle control.
- Determine the IC50:
  - Plot the normalized data against the logarithm of the **UNC6934** concentration.
  - Fit the data to a four-parameter dose-response curve to determine the IC50 value.

## Troubleshooting

Issue	Possible Cause	Suggested Solution
Low Luminescence Signal	Low transfection efficiency.	Optimize transfection reagent to DNA ratio and cell density at transfection.
Low cell number in assay wells.	Ensure accurate cell counting and plating.	
Inactive substrate.	Use freshly prepared NanoBRET® Nano-Glo® Substrate.	
High Background Signal	Spectral overlap.	Ensure the use of appropriate filters on the luminometer.
Autofluorescence of compounds.	Run a control with compound-treated, untransfected cells.	
High Variability between Replicates	Inconsistent cell plating.	Ensure a homogenous cell suspension before plating.
Inaccurate pipetting.	Use calibrated pipettes and proper technique.	
No Dose-Response with UNC6934	Inactive compound.	Verify the integrity and concentration of the UNC6934 stock.
Incorrect fusion protein constructs.	Sequence verify the plasmids. Test different N- and C-terminal fusions.	
Assay window is too small.	Optimize the ratio of donor to acceptor plasmids during transfection.	

## Conclusion

The NanoBRET™ PPI assay is a robust method for quantifying the intracellular engagement of **UNC6934** with its target, the NSD2 PWWP1 domain. By following the detailed protocols and

guidelines presented in these application notes, researchers can accurately determine the potency of **UNC6934** and similar compounds in a live-cell format, providing valuable insights for chemical biology and drug discovery efforts targeting the NSD protein family.

#### *Need Custom Synthesis?*

*BenchChem offers custom synthesis for rare earth carbides and specific isotopic labeling.*

*Email: [info@benchchem.com](mailto:info@benchchem.com) or [Request Quote Online](#).*

## References

- [1. A Luminescent Pull-Down Approach to Confirm NanoBRET® Protein Interaction Assays \[worldwide.promega.com\]](#)
- [2. promega.com \[promega.com\]](#)
- [3. pubs.acs.org \[pubs.acs.org\]](#)
- [4. promegaconnections.com \[promegaconnections.com\]](#)
- [5. promega.com \[promega.com\]](#)
- [6. NanoBRET® Nano-Glo® Detection Systems \[promega.com\]](#)
- [7. NanoBRET® PPI Starter Systems \[worldwide.promega.com\]](#)
- [8. NanoBRET™ Protein:Protein Interaction System Protocol \[promega.com\]](#)
- [9. promega.com \[promega.com\]](#)
- [10. selleckchem.com \[selleckchem.com\]](#)
- To cite this document: BenchChem. [Application Notes and Protocols for Utilizing UNC6934 in a NanoBRET™ Assay]. BenchChem, [2026]. [Online PDF]. Available at: [\[https://www.benchchem.com/product/b15588771/docs#application-notes-and-protocols-for-utilizing-unc6934-in-a-nanobret-assay\]](https://www.benchchem.com/product/b15588771/docs#application-notes-and-protocols-for-utilizing-unc6934-in-a-nanobret-assay)

---

### Disclaimer & Data Validity:

The information provided in this document is for Research Use Only (RUO) and is strictly not intended for diagnostic or therapeutic procedures. While BenchChem strives to provide accurate protocols, we make no warranties, express or implied, regarding the fitness of this product for every specific experimental setup.

**Technical Support:** The protocols provided are for reference purposes. Unsure if this reagent suits your experiment?

**Need Industrial/Bulk Grade?** [Request Custom Synthesis Quote](#)

## BenchChem

Our mission is to be the trusted global source of essential and advanced chemicals, empowering scientists and researchers to drive progress in science and industry.

### Contact

Address: 3281 E Guasti Rd  
Ontario, CA 91761, United States  
Phone: (601) 213-4426  
Email: [info@benchchem.com](mailto:info@benchchem.com)

[Contact our Ph.D. Support Team for a compatibility check](#)