

# UNC7145: A Comparative Guide to a High-Quality NSD2 Inhibitor Negative Control

**Author:** BenchChem Technical Support Team. **Date:** April 2026

## Compound of Interest

Compound Name: *UNC7145*  
Cat. No.: *B15587662*

[Get Quote](#)

In the pursuit of selective therapeutic agents targeting the NSD2 methyltransferase, the use of appropriate negative controls is paramount to validate on-target effects and rule out confounding off-target activities. This guide provides a detailed comparison of **UNC7145**, the inactive enantiomer and negative control for the potent NSD2-PWWP1 domain inhibitor UNC6934, against its active counterpart. The data presented herein, primarily from the seminal work of Dilworth et al., underscores the necessity of employing such controls for robust scientific conclusions.[1]

## Introduction to **UNC7145** and its Role as a Negative Control

**UNC7145** is a crucial tool for researchers studying the biological functions of the NSD2 protein, a histone methyltransferase implicated in various cancers. It serves as a negative control for UNC6934, a chemical probe that potently and selectively targets the PWWP1 domain of NSD2. [2][3][4] Structurally, **UNC7145** is nearly identical to UNC6934, with the critical difference being the substitution of a cyclopropyl group in UNC6934 with an isopropyl group in **UNC7145**. This seemingly minor alteration dramatically reduces its binding affinity for the NSD2-PWWP1 domain, rendering it biologically inactive in relevant assays.[1] The availability of this well-

characterized negative control allows for rigorous assessment of the specificity of UNC6934's effects in cellular and biochemical assays.

## Comparative Analysis of UNC7145 and UNC6934

The efficacy and specificity of a chemical probe are best understood when compared directly with a closely related but inactive compound. The following tables summarize the key quantitative differences between UNC6934 and its negative control, **UNC7145**.

### Table 1: In Vitro Binding and Functional Activity

Parameter	UNC6934	UNC7145	Reference
Binding Affinity (Kd) to NSD2-PWWP1 (SPR)	91 ± 8 nM	No measurable binding	[5]
Inhibition of NSD2-PWWP1-H3K36me2 Interaction (IC50, AlphaScreen)	104 ± 13 nM	No measurable effect	[5]

### Table 2: Cellular Target Engagement

Assay	UNC6934	UNC7145	Reference
NanoBRET Protein-Protein Interaction Assay (EC50)	1.23 ± 0.25 μM	No dose-dependent effect	[1]
Chemical Proteomics (Pull-down from KMS-11 lysates)	Selectively pulls down NSD2	No significant enrichment of NSD2	[1]

### Table 3: Selectivity Profile (Differential Scanning Fluorimetry, ΔTm in °C at 100 μM)

PWWP Domain	UNC6934 ( $\Delta T_m$ )	UNC7145 ( $\Delta T_m$ )	Reference
NSD2-PWWP1	>10	<1	[1]
NSD1-PWWP1	<1	<1	[1]
NSD3-PWWP1	<1	<1	[1]
ZMYND11-PWWP	<1	<1	[1]
MSH6-PWWP	<1	<1	[1]
DNMT3A-PWWP	<1	<1	[1]
BRPF1-PWWP	<1	<1	[1]
...and 9 other PWWP domains	<1	<1	[1]

Note: A higher  $\Delta T_m$  value indicates greater stabilization of the protein upon compound binding, signifying a direct interaction.

## Experimental Protocols

Detailed methodologies are crucial for the replication and validation of scientific findings. Below are the protocols for the key experiments cited in this guide.

### Surface Plasmon Resonance (SPR) for Binding Affinity

- **Immobilization:** Recombinant human NSD2-PWWP1 protein is immobilized on a CM5 sensor chip using standard amine coupling chemistry.
- **Binding Analysis:** A dilution series of UNC6934 and **UNC7145** in a suitable buffer (e.g., HBS-EP+) is injected over the sensor surface.
- **Data Acquisition:** The association and dissociation of the compounds are monitored in real-time.
- **Data Analysis:** The resulting sensorgrams are fitted to a 1:1 binding model to determine the equilibrium dissociation constant ( $K_d$ ).

## AlphaScreen Assay for Inhibition of Protein-Protein Interaction

- Reagents: Biotinylated H3K36me2 peptide, GST-tagged NSD2-PWWP1, Streptavidin-coated Donor beads, and anti-GST Acceptor beads are used.
- Assay Procedure:
  - A mixture of GST-NSD2-PWWP1 and biotinylated H3K36me2 peptide is incubated with varying concentrations of UNC6934 or **UNC7145**.
  - Streptavidin-Donor beads and anti-GST Acceptor beads are added to the mixture.
  - The plate is incubated in the dark to allow for bead-protein complex formation.
- Detection: The AlphaScreen signal is read on an appropriate plate reader. A decrease in signal indicates inhibition of the interaction.
- Data Analysis: IC50 values are calculated from the dose-response curves.

## NanoBRET™ Protein-Protein Interaction (PPI) Assay for Cellular Target Engagement

- Cell Preparation: U2OS cells are co-transfected with plasmids encoding for NanoLuc-NSD2-PWWP1 (donor) and HaloTag-Histone H3.3 (acceptor).
- Compound Treatment: Transfected cells are treated with a dilution series of UNC6934 or **UNC7145**.
- Lysis and Substrate Addition: Cells are lysed, and the NanoBRET™ Nano-Glo® Substrate and a chloroalkane fluorophore (acceptor ligand) are added.
- Detection: The donor (460 nm) and acceptor (618 nm) emission signals are measured.
- Data Analysis: The BRET ratio (acceptor emission/donor emission) is calculated and plotted against the compound concentration to determine the EC50.

## Differential Scanning Fluorimetry (DSF) for Selectivity Profiling

- **Reaction Mixture:** A solution containing the target protein (e.g., NSD2-PWWP1 or other PWWP domains), a fluorescent dye (e.g., SYPRO Orange), and either UNC6934, **UNC7145**, or DMSO is prepared.
- **Thermal Denaturation:** The reaction mixture is subjected to a temperature gradient in a real-time PCR instrument.
- **Fluorescence Monitoring:** The fluorescence of the dye is monitored as the temperature increases. The dye fluoresces upon binding to hydrophobic regions of the protein that are exposed during unfolding.
- **Data Analysis:** The melting temperature ( $T_m$ ), the temperature at which 50% of the protein is unfolded, is determined from the peak of the first derivative of the melting curve. The change in melting temperature ( $\Delta T_m$ ) in the presence of the compound compared to the DMSO control is calculated.

## Visualizing NSD2 Signaling and Experimental Logic

To further clarify the context of **UNC7145**'s application, the following diagrams illustrate the NSD2 signaling pathway and the logical workflow for validating an on-target effect using a negative control.

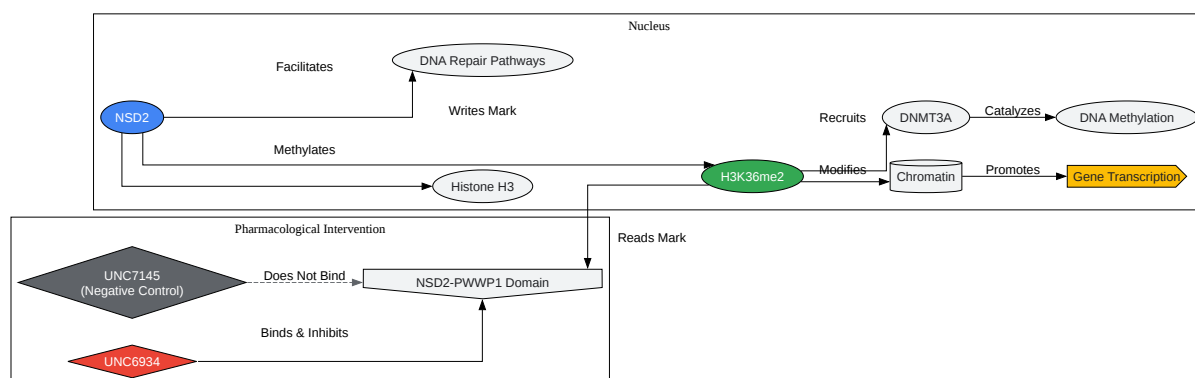

[Click to download full resolution via product page](#)

Caption: NSD2 signaling pathway and points of intervention.

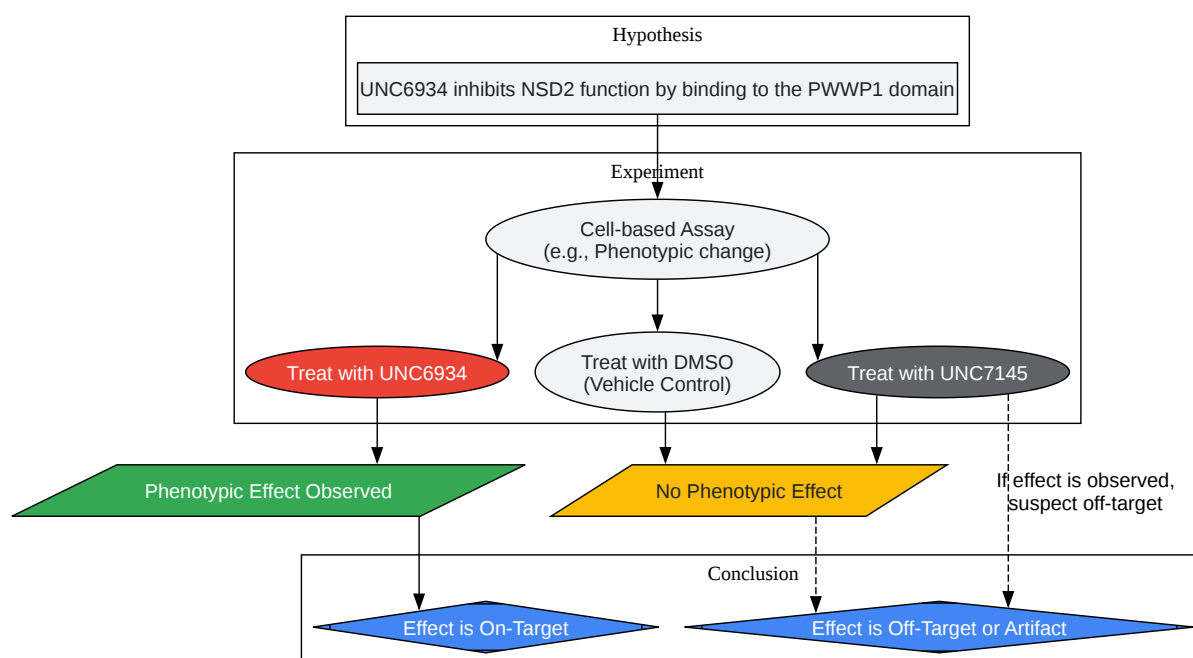

[Click to download full resolution via product page](#)

Caption: Logical workflow for validating on-target effects.

## Conclusion

The data overwhelmingly supports the use of **UNC7145** as a highly specific and appropriate negative control for studies involving the NSD2-PWWP1 inhibitor UNC6934. While UNC6934 demonstrates potent binding to the NSD2-PWWP1 domain, inhibits its interaction with its biological substrate, and engages the target in cells, **UNC7145** is consistently inactive across

all these assays.[1][5] This stark difference in activity, despite their structural similarity, provides a robust framework for attributing the biological effects of UNC6934 to its specific inhibition of the NSD2-PWWP1 domain. For researchers in the field of epigenetics and drug discovery, the combined use of UNC6934 and **UNC7145** represents a best-practice approach for elucidating the biological roles of NSD2 and for the validation of this therapeutic target.

### Need Custom Synthesis?

BenchChem offers custom synthesis for rare earth carbides and specific isotopic labeling.

Email: [info@benchchem.com](mailto:info@benchchem.com) or [Request Quote Online](#).

## References

- [1. A chemical probe targeting the PWWP domain alters NSD2 nucleolar localization - PMC \[pmc.ncbi.nlm.nih.gov\]](#)
- [2. researchgate.net \[researchgate.net\]](#)
- [3. rcsb.org \[rcsb.org\]](#)
- [4. axonmedchem.com \[axonmedchem.com\]](#)
- [5. biorxiv.org \[biorxiv.org\]](#)
- To cite this document: BenchChem. [UNC7145: A Comparative Guide to a High-Quality NSD2 Inhibitor Negative Control]. BenchChem, [2026]. [Online PDF]. Available at: [\[https://www.benchchem.com/product/b15587662/docs#unc7145-a-comparative-guide-to-a-high-quality-nsd2-inhibitor-negative-control\]](https://www.benchchem.com/product/b15587662/docs#unc7145-a-comparative-guide-to-a-high-quality-nsd2-inhibitor-negative-control)

---

### Disclaimer & Data Validity:

The information provided in this document is for Research Use Only (RUO) and is strictly not intended for diagnostic or therapeutic procedures. While BenchChem strives to provide accurate protocols, we make no warranties, express or implied, regarding the fitness of this product for every specific experimental setup.

**Technical Support:** The protocols provided are for reference purposes. Unsure if this reagent suits your experiment?

**Need Industrial/Bulk Grade?** [Request Custom Synthesis Quote](#)

## BenchChem

Our mission is to be the trusted global source of essential and advanced chemicals, empowering scientists and researchers to drive progress in science and industry.

### Contact

Address: 3281 E Guasti Rd  
Ontario, CA 91761, United States  
Phone: (601) 213-4426  
Email: [info@benchchem.com](mailto:info@benchchem.com)

[Contact our Ph.D. Support Team for a compatibility check](#)