

Application Notes and Protocols for Studying PRC1 Complex Disruption Using UNC4976

Author: BenchChem Technical Support Team. **Date:** April 2026

Compound of Interest

Compound Name: *UNC4976*
Cat. No.: *B15587843*

[Get Quote](#)

For Researchers, Scientists, and Drug Development Professionals

Introduction

The Polycomb Repressive Complex 1 (PRC1) is a crucial epigenetic regulator involved in the maintenance of gene repression, playing a pivotal role in development and cellular identity.[1] Dysregulation of PRC1 activity is frequently implicated in various human diseases, including cancer, making it an attractive target for therapeutic intervention.[2] This document provides detailed application notes and experimental protocols for utilizing **UNC4976**, a potent and specific chemical probe, to study the disruption of the PRC1 complex.

UNC4976 is a peptidomimetic that acts as a positive allosteric modulator (PAM) of the CBX7 chromodomain, a key component of the canonical PRC1 (cPRC1) complex.[2][3] Its unique mechanism of action involves antagonizing the H3K27me3-specific recruitment of CBX7 to target genes while simultaneously enhancing non-specific binding to DNA and RNA.[2][3] This dual activity leads to a redistribution of PRC1 away from its target gene loci, effectively disrupting its repressive function.[2][3] These application notes will guide researchers in using **UNC4976** to investigate PRC1 biology and for the development of novel therapeutic strategies.

Mechanism of Action of UNC4976

The canonical PRC1 complex is recruited to chromatin through the interaction of its CBX subunit with the histone mark H3K27me3, which is deposited by the Polycomb Repressive Complex 2 (PRC2).[4] Once recruited, the RING1A/RING1B subunit of PRC1 catalyzes the monoubiquitination of histone H2A at lysine 119 (H2AK119ub1), leading to chromatin compaction and gene silencing.[4]

UNC4976 disrupts this process by binding to the CBX7 chromodomain. This binding event has two key consequences:

- **Antagonism of H3K27me3 Binding:** **UNC4976** competitively inhibits the interaction between the CBX7 chromodomain and the H3K27me3 mark on histones.[2][3] This prevents the targeted recruitment of the PRC1 complex to its specific gene loci.
- **Positive Allosteric Modulation of Nucleic Acid Binding:** **UNC4976** allosterically enhances the affinity of the CBX7 chromodomain for both DNA and RNA.[2][3] This leads to the sequestration of CBX7-containing PRC1 complexes away from their intended targets and onto other nucleic acid structures.

The net effect is a significant reduction in PRC1 occupancy at its target genes, leading to de-repression of gene expression.[3]

Mechanism of UNC4976 Action on PRC1 Complex

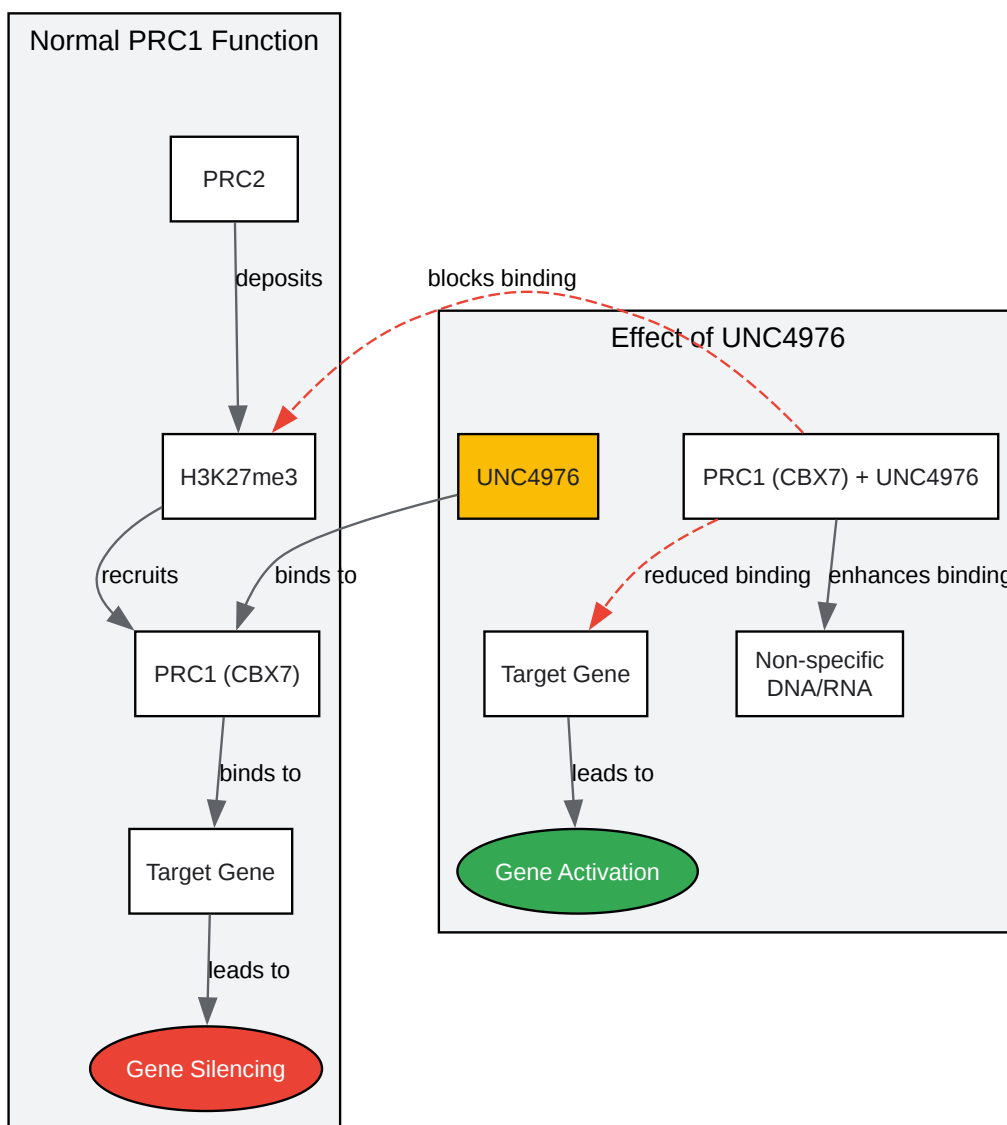

[Click to download full resolution via product page](#)

Mechanism of **UNC4976** disrupting PRC1 function.

Data Presentation

Table 1: In Vitro and Cellular Activity of **UNC4976**

Assay Type	Target/System	Compound	IC50 / EC50 (µM)	Notes	Reference
Biochemical					
Fluorescence Polarization (vs. H3K27me3 peptide)	CBX7 Chromodoma in	UNC4976	0.18 ± 0.02	Competitive displacement of a fluorescently labeled H3K27me3 peptide.	[3]
Fluorescence Polarization (vs. H3K27me3 peptide)	CBX7 Chromodoma in	UNC3866	0.21 ± 0.01	A previously published, less potent cellular probe.	[3]
Cellular					
Polycomb in-vivo Assay (GFP Reporter)	mESCs with CBX7-ZF-HD1 fusion	UNC4976	0.7 ± 0.1	Measures the derepression of a GFP reporter gene silenced by a recruited PRC1 complex.	[3]
Polycomb in-vivo Assay (GFP Reporter)	mESCs with CBX7-ZF-HD1 fusion	UNC3866	9.8 ± 1.2	UNC4976 shows a 14-fold enhancement in cellular efficacy over UNC3866.	[3]

Cell Viability (CellTiter-Glo)	PC3 cells (72h treatment)	UNC4976	> 50	Indicates low cytotoxicity at effective concentration s.	[3]
--------------------------------	---------------------------	---------	------	--	---------------------

Table 2: Effect of UNC4976 on PRC1 Chromatin Occupancy

Experiment	Cell Line	Target	Treatment	Change in Occupancy	Reference
ChIP-seq	mESCs	CBX7	20 μ M UNC4976 (4h)	Substantial reduction at high and intermediate PRC1 target TSSs.	[3]
ChIP-seq	mESCs	RING1B	20 μ M UNC4976 (4h)	Substantial reduction at high and intermediate PRC1 target TSSs.	[3]
ChIP-seq	mESCs	CBX7	20 μ M UNC3866 (4h)	Less pronounced reduction compared to UNC4976.	[3]
ChIP-seq	mESCs	RING1B	20 μ M UNC3866 (4h)	Less pronounced reduction compared to UNC4976.	[3]

Experimental Protocols

Polycomb in-vivo Assay (GFP Reporter Assay)

This cell-based assay quantitatively measures the ability of a compound to disrupt PRC1-mediated gene silencing. It utilizes a mouse embryonic stem cell (mESC) line with a stably integrated GFP reporter gene under the control of a promoter that is silenced by a dCas9-CBX7 fusion protein targeted to the promoter region.

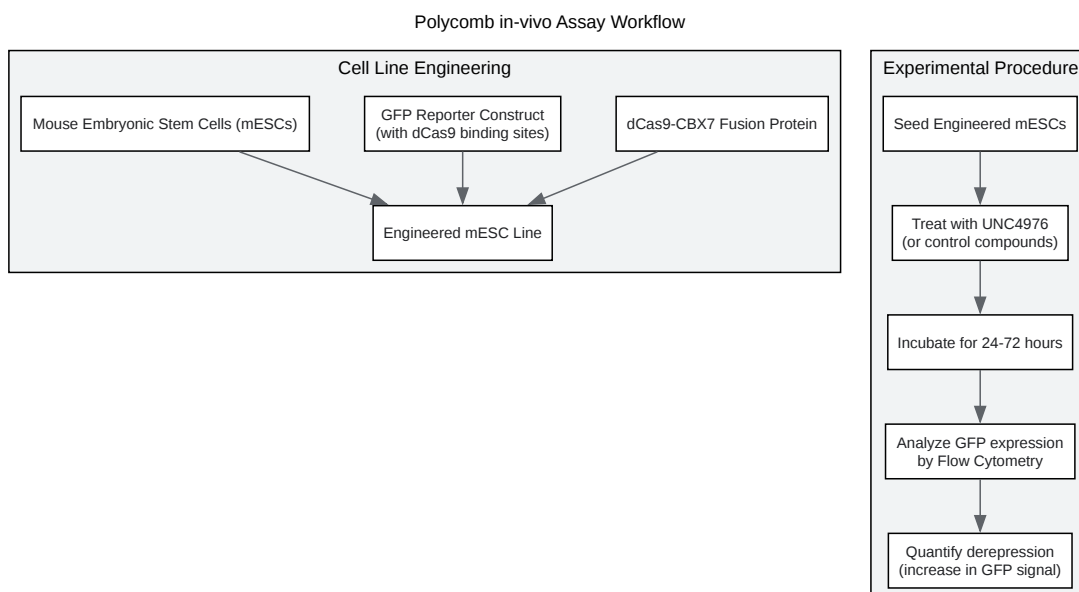

[Click to download full resolution via product page](#)

Workflow for the Polycomb in-vivo GFP Reporter Assay.

Materials:

- Engineered mESC line with dCas9-CBX7 and GFP reporter
- DMEM, high glucose
- Fetal Bovine Serum (FBS)
- Penicillin-Streptomycin
- LIF (Leukemia Inhibitory Factor)
- 2i (PD0325901 and CHIR99021)
- **UNC4976**, UNC3866 (positive control), UNC4219 (negative control)
- DMSO (vehicle control)
- 96-well plates
- Flow cytometer

Protocol:

- Cell Culture: Culture the engineered mESCs in DMEM supplemented with 15% FBS, Penicillin-Streptomycin, LIF, and 2i on gelatin-coated plates.
- Cell Seeding: Seed 5,000 cells per well in a 96-well plate and allow them to adhere overnight.
- Compound Treatment: Prepare serial dilutions of **UNC4976** and control compounds in culture medium. The final DMSO concentration should not exceed 0.1%.
- Incubation: Add the compound dilutions to the cells and incubate for 48-72 hours.
- Flow Cytometry:

- Wash the cells with PBS.
- Trypsinize the cells and resuspend in PBS containing 2% FBS.
- Analyze GFP fluorescence using a flow cytometer.
- Data Analysis:
 - Gate on the live cell population.
 - Calculate the percentage of GFP-positive cells and the mean fluorescence intensity.
 - Normalize the data to the vehicle control (DMSO) and plot dose-response curves to determine the EC50 values.

Chromatin Immunoprecipitation followed by Sequencing (ChIP-seq)

ChIP-seq is used to map the genome-wide occupancy of PRC1 components (e.g., CBX7, RING1B) and assess the effect of **UNC4976** on their chromatin binding.

Materials:

- mESCs or other relevant cell line
- **UNC4976** and control compounds
- Formaldehyde (37%)
- Glycine
- Lysis buffer
- Sonication buffer
- ChIP dilution buffer
- Protein A/G magnetic beads

- Antibodies: anti-CBX7, anti-RING1B, IgG (control)
- Wash buffers
- Elution buffer
- Proteinase K
- RNase A
- DNA purification kit
- Next-generation sequencing platform

Protocol:

- Cell Treatment and Crosslinking:
 - Culture mESCs to ~80% confluency.
 - Treat cells with 20 μ M **UNC4976** or control compounds for 4 hours.
 - Crosslink proteins to DNA by adding formaldehyde to a final concentration of 1% and incubating for 10 minutes at room temperature.
 - Quench the crosslinking reaction by adding glycine to a final concentration of 125 mM.
- Cell Lysis and Chromatin Shearing:
 - Harvest and lyse the cells.
 - Shear the chromatin to an average size of 200-500 bp using sonication.
- Immunoprecipitation:
 - Pre-clear the chromatin with protein A/G beads.
 - Incubate the chromatin overnight at 4°C with the specific antibody (e.g., anti-CBX7) or IgG control.

- Capture the antibody-chromatin complexes with protein A/G beads.
- Washes and Elution:
 - Wash the beads to remove non-specific binding.
 - Elute the chromatin from the beads.
- Reverse Crosslinking and DNA Purification:
 - Reverse the crosslinks by incubating at 65°C overnight.
 - Treat with RNase A and Proteinase K.
 - Purify the DNA using a DNA purification kit.
- Library Preparation and Sequencing:
 - Prepare sequencing libraries from the purified DNA.
 - Perform high-throughput sequencing.
- Data Analysis:
 - Align the sequencing reads to the reference genome.
 - Perform peak calling to identify regions of protein binding.
 - Compare the peak profiles between **UNC4976**-treated and control samples to determine changes in PRC1 occupancy.

Fluorescence Polarization (FP) Assay

This biochemical assay measures the binding of the CBX7 chromodomain to nucleic acids and how this is modulated by **UNC4976**.

Materials:

- Purified CBX7 chromodomain protein

- Fluorescently labeled dsDNA or RNA probe (e.g., FAM-dsDNA)
- **UNC4976** and control compounds
- Assay buffer (e.g., PBS with 0.01% Tween-20)
- 384-well black plates
- Fluorescence plate reader with polarization filters

Protocol:

- Assay Setup:
 - Prepare a solution of the CBX7 chromodomain (e.g., 30 μ M) and the fluorescently labeled nucleic acid probe (e.g., 100 nM) in the assay buffer.
 - Prepare serial dilutions of **UNC4976** and control compounds.
- Incubation:
 - Add the CBX7/probe solution and the compound dilutions to the wells of a 384-well plate.
 - Incubate at room temperature for 30 minutes to allow binding to reach equilibrium.
- Measurement:
 - Measure the fluorescence polarization using a plate reader.
- Data Analysis:
 - Normalize the fluorescence polarization signal.
 - Plot the change in polarization as a function of compound concentration to determine the effect of **UNC4976** on the CBX7-nucleic acid interaction. An increase in polarization indicates enhanced binding.

Cell Viability Assay (CellTiter-Glo)

This assay is used to assess the cytotoxicity of **UNC4976**.

Materials:

- Cell line of interest (e.g., PC3)
- **UNC4976**
- CellTiter-Glo Luminescent Cell Viability Assay kit
- Opaque-walled 96-well plates
- Luminometer

Protocol:

- Cell Seeding: Seed cells in an opaque-walled 96-well plate and allow them to adhere overnight.
- Compound Treatment: Treat the cells with a serial dilution of **UNC4976** for 72 hours.
- Assay Procedure:
 - Equilibrate the plate and the CellTiter-Glo reagent to room temperature.
 - Add a volume of CellTiter-Glo reagent equal to the volume of culture medium in each well.
 - Mix on an orbital shaker for 2 minutes to induce cell lysis.
 - Incubate at room temperature for 10 minutes to stabilize the luminescent signal.
- Measurement: Measure the luminescence using a luminometer.
- Data Analysis: Normalize the luminescent signal to the vehicle control and plot the percentage of cell viability against the compound concentration to determine the IC50 value.

Conclusion

UNC4976 is a valuable chemical probe for studying the role of the PRC1 complex in gene regulation and disease. Its unique mechanism as a positive allosteric modulator of CBX7 provides a powerful tool to dissect the intricacies of Polycomb-mediated gene silencing. The protocols and data presented here offer a comprehensive guide for researchers to effectively utilize **UNC4976** in their studies, paving the way for new discoveries in epigenetics and the development of novel therapeutic agents targeting the PRC1 complex.

Need Custom Synthesis?

BenchChem offers custom synthesis for rare earth carbides and specific isotopic labeling.

Email: info@benchchem.com or [Request Quote Online](#).

References

- [1. ch.promega.com \[ch.promega.com\]](https://www.ch.promega.com)
- [2. Fluorescence Polarization Assay Protocol: A Step-by-Step Guide for Accurate Measurements - nanomicronspheres \[nanomicronspheres.com\]](#)
- [3. CellTiter-Glo® Luminescent Cell Viability Assay Protocol \[promega.com\]](#)
- [4. Co-immunoprecipitation Protocols \[cormedix-europe.com\]](#)
- To cite this document: BenchChem. [Application Notes and Protocols for Studying PRC1 Complex Disruption Using UNC4976]. BenchChem, [2026]. [Online PDF]. Available at: [\[https://www.benchchem.com/product/b15587843/docs#application-notes-and-protocols-for-studying-prc1-complex-disruption-using-unc4976\]](https://www.benchchem.com/product/b15587843/docs#application-notes-and-protocols-for-studying-prc1-complex-disruption-using-unc4976)

Disclaimer & Data Validity:

The information provided in this document is for Research Use Only (RUO) and is strictly not intended for diagnostic or therapeutic procedures. While BenchChem strives to provide accurate protocols, we make no warranties, express or implied, regarding the fitness of this product for every specific experimental setup.

Technical Support: The protocols provided are for reference purposes. Unsure if this reagent suits your experiment?

Need Industrial/Bulk Grade? [Request Custom Synthesis Quote](#)

BenchChem

Our mission is to be the trusted global source of essential and advanced chemicals, empowering scientists and researchers to drive progress in science and industry.

Contact

Address: 3281 E Guasti Rd
Ontario, CA 91761, United States
Phone: (601) 213-4426
Email: info@benchchem.com

[Contact our Ph.D. Support Team for a compatibility check](#)