

# Application Notes and Protocols: UNC4976 for In Vitro Assays

**Author:** BenchChem Technical Support Team. **Date:** April 2026

## Compound of Interest

Compound Name: UNC4976  
Cat. No.: B15587843

[Get Quote](#)

## For Researchers, Scientists, and Drug Development Professionals

Introduction:

**UNC4976** is a potent, cell-permeable chemical probe that acts as a positive allosteric modulator (PAM) of the CBX7 chromodomain, a core component of the Polycomb Repressive Complex 1 (PRC1).<sup>[1][2][3]</sup> Its unique mechanism of action involves the simultaneous antagonism of H3K27me3-specific recruitment of CBX7 to target genes and the enhancement of non-specific binding to DNA and RNA.<sup>[1][4]</sup> This effectively re-distributes PRC1 away from its canonical gene targets, leading to their de-repression. These application notes provide detailed protocols and recommended concentrations for the use of **UNC4976** in various in vitro assays to probe its biological function and therapeutic potential.

## Data Presentation: Recommended UNC4976 Concentrations

The following table summarizes the effective concentrations of **UNC4976** used in key in vitro assays as reported in the literature. These values serve as a starting point for experimental

design and may require further optimization depending on the specific cell line and experimental conditions.

Assay Type	Cell Line / System	Concentration Range	Key Findings	Reference
CBX7 GFP Reporter Assay	Mouse Embryonic Stem Cells (mESCs)	0.1 - 100 $\mu$ M	EC <sub>50</sub> = 3.207 $\pm$ 0.352 $\mu$ M	[1]
Chromatin Immunoprecipitation Sequencing (ChIP-seq)	Mouse Embryonic Stem Cells (mESCs)	20 $\mu$ M (4-hour treatment)	Displacement of CBX7 and RING1B from endogenous targets	[1]
Cell Viability Assay (CellTiter-Glo)	Mouse Embryonic Stem Cells (mESCs)	Up to 100 $\mu$ M	Weak toxicity observed at 100 $\mu$ M	[1]
Fluorescence Polarization (FP) Assay	Purified CBX7 chromodomain	30 $\mu$ M (CBX7), 100 nM (FAM-dsDNA/RNA)	Enhances CBX7 binding to nucleic acids	[1]
Chemiprecipitation	PC3 cells	Not specified	Used to assess binding to CBX proteins in cell lysates	[1]

## Signaling Pathway and Experimental Workflow

To facilitate a deeper understanding of **UNC4976**'s mechanism and its application in experimental settings, the following diagrams illustrate its signaling pathway and a typical in vitro experimental workflow.

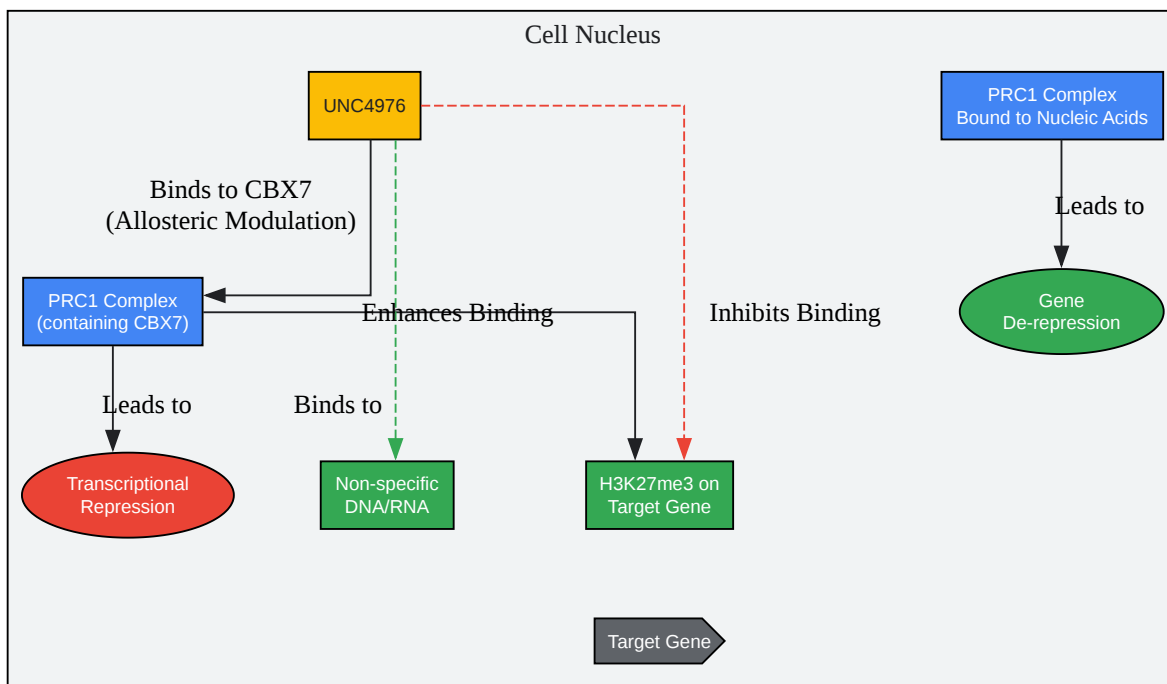

[Click to download full resolution via product page](#)

**UNC4976 Mechanism of Action**

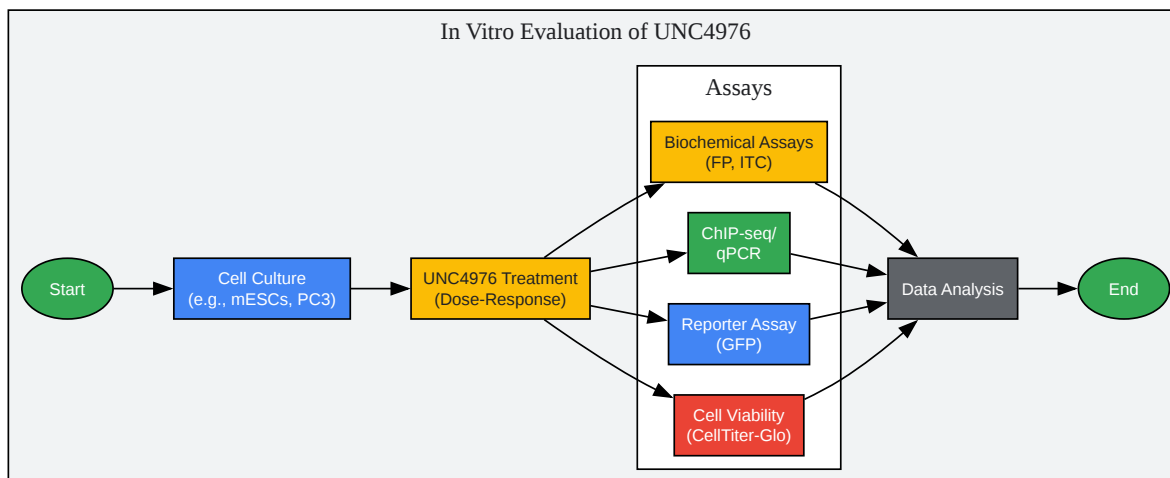

[Click to download full resolution via product page](#)

### Experimental Workflow for **UNC4976**

## Experimental Protocols

### CBX7 GFP Reporter Assay

This assay is designed to quantify the ability of **UNC4976** to de-repress a GFP reporter gene that is silenced by a CBX7-dependent mechanism in mouse embryonic stem cells (mESCs).

Materials:

- mESCs harboring a CBX7-repressible GFP reporter
- Complete mESC culture medium
- **UNC4976** stock solution (e.g., 10 mM in DMSO)
- 96-well cell culture plates

- Flow cytometer

Protocol:

- Seed mESCs in a 96-well plate at a density that allows for logarithmic growth during the experiment.
- Allow cells to adhere and grow for 24 hours.
- Prepare a serial dilution of **UNC4976** in complete culture medium. A typical concentration range would be from 0.1  $\mu\text{M}$  to 100  $\mu\text{M}$ . Include a DMSO-only control.
- Remove the old medium from the cells and add the medium containing the different concentrations of **UNC4976**.
- Incubate the cells for 48-72 hours.
- Harvest the cells by trypsinization.
- Analyze GFP expression in the cell population using a flow cytometer.
- Calculate the percentage of GFP-positive cells for each concentration and determine the  $\text{EC}_{50}$  value.

## Cell Viability Assay (CellTiter-Glo®)

This assay measures cell viability by quantifying ATP, which is an indicator of metabolically active cells.

Materials:

- Cells of interest (e.g., mESCs)
- **UNC4976** stock solution
- Opaque-walled 96-well plates
- CellTiter-Glo® Luminescent Cell Viability Assay kit (Promega)

- Luminometer

Protocol:

- Seed cells in an opaque-walled 96-well plate at a suitable density.
- After 24 hours, treat the cells with a serial dilution of **UNC4976** (e.g., 0.1  $\mu$ M to 100  $\mu$ M) and a DMSO control.
- Incubate for the desired treatment duration (e.g., 72 hours).
- Equilibrate the plate to room temperature for approximately 30 minutes.[\[5\]](#)[\[6\]](#)
- Prepare the CellTiter-Glo<sup>®</sup> reagent according to the manufacturer's instructions.[\[5\]](#)[\[7\]](#)
- Add a volume of CellTiter-Glo<sup>®</sup> reagent equal to the volume of cell culture medium in each well.[\[5\]](#)[\[6\]](#)
- Mix the contents on an orbital shaker for 2 minutes to induce cell lysis.[\[5\]](#)
- Incubate at room temperature for 10 minutes to stabilize the luminescent signal.[\[5\]](#)[\[6\]](#)
- Measure luminescence using a plate reader.
- Express the results as a percentage of the viability of the DMSO-treated control cells.

## Fluorescence Polarization (FP) Assay

This biochemical assay is used to measure the binding of **UNC4976** to the CBX7 chromodomain and its effect on the interaction with nucleic acids.

Materials:

- Purified CBX7 chromodomain protein
- Fluorescently labeled double-stranded DNA (e.g., FAM-dsDNA) or RNA probe
- **UNC4976**

- Assay buffer (e.g., 20 mM Tris-HCl pH 8.0, 150 mM NaCl, 1 mM TCEP)
- Black, non-binding 384-well plates
- Plate reader with FP capabilities

Protocol:

- Prepare a solution containing the CBX7 chromodomain (e.g., 30  $\mu$ M) and the fluorescently labeled nucleic acid probe (e.g., 100 nM) in the assay buffer.[1]
- Prepare a serial dilution of **UNC4976** in the assay buffer.
- In a 384-well plate, add the **UNC4976** dilutions.
- Add the CBX7/probe mixture to each well.
- Include controls for the probe alone (no protein) and probe with protein (no compound).
- Incubate the plate at room temperature for a sufficient time to reach binding equilibrium (e.g., 30 minutes).
- Measure fluorescence polarization on a plate reader.
- Analyze the data to determine the effect of **UNC4976** on the binding of CBX7 to the nucleic acid probe.

## Chromatin Immunoprecipitation (ChIP)

ChIP is used to determine the occupancy of CBX7 and other PRC1 components on specific genomic regions in response to **UNC4976** treatment.

Materials:

- Cells of interest (e.g., mESCs)
- **UNC4976** (20  $\mu$ M working concentration)
- Formaldehyde for cross-linking

- CHIP-grade antibodies against CBX7, RING1B, or other proteins of interest
- Protein A/G magnetic beads
- Buffers for cell lysis, chromatin shearing, immunoprecipitation, washing, and elution
- Reagents for reverse cross-linking and DNA purification
- qPCR or sequencing reagents

Protocol:

- Culture cells to confluency.
- Treat cells with 20  $\mu$ M **UNC4976** or DMSO for 4 hours.[1]
- Cross-link proteins to DNA by adding formaldehyde directly to the culture medium (1% final concentration) and incubating for 10 minutes at room temperature.
- Quench the cross-linking reaction with glycine.
- Harvest and lyse the cells to isolate nuclei.
- Shear the chromatin by sonication to an average fragment size of 200-500 bp.
- Pre-clear the chromatin with Protein A/G beads.
- Immunoprecipitate the chromatin overnight with the antibody of interest.
- Capture the antibody-chromatin complexes with Protein A/G beads.
- Wash the beads to remove non-specific binding.
- Elute the chromatin from the beads.
- Reverse the cross-links by heating in the presence of high salt.
- Purify the DNA.

- Analyze the DNA by qPCR using primers for specific target genes or by next-generation sequencing (ChIP-seq).

#### *Need Custom Synthesis?*

*BenchChem offers custom synthesis for rare earth carbides and specific isotopic labeling.*

*Email: [info@benchchem.com](mailto:info@benchchem.com) or [Request Quote Online](#).*

## References

- [1. Discovery and Characterization of a Cellularly Potent Positive Allosteric Modulator of the Polycomb Repressive Complex 1 Chromodomain, CBX7 - PMC \[pmc.ncbi.nlm.nih.gov\]](#)
- [2. Reprogramming CBX8-PRC1 function with a positive allosteric modulator - PMC \[pmc.ncbi.nlm.nih.gov\]](#)
- [3. Discovery and Characterization of a Cellular Potent Positive Allosteric Modulator of the Polycomb Repressive Complex 1 Chromodomain, CBX7 - PubMed \[pubmed.ncbi.nlm.nih.gov\]](#)
- [4. medchemexpress.com \[medchemexpress.com\]](#)
- [5. OUH - Protocols \[ous-research.no\]](#)
- [6. ch.promega.com \[ch.promega.com\]](#)
- [7. CellTiter-Glo® Luminescent Cell Viability Assay Protocol \[promega.com\]](#)
- To cite this document: BenchChem. [Application Notes and Protocols: UNC4976 for In Vitro Assays]. BenchChem, [2026]. [Online PDF]. Available at: [\[https://www.benchchem.com/product/b15587843/docs#application-notes-and-protocols-unc4976-for-in-vitro-assays\]](https://www.benchchem.com/product/b15587843/docs#application-notes-and-protocols-unc4976-for-in-vitro-assays)

---

### Disclaimer & Data Validity:

The information provided in this document is for Research Use Only (RUO) and is strictly not intended for diagnostic or therapeutic procedures. While BenchChem strives to provide accurate protocols, we make no warranties, express or implied, regarding the fitness of this product for every specific experimental setup.

**Technical Support:** The protocols provided are for reference purposes. Unsure if this reagent suits your experiment?

**Need Industrial/Bulk Grade?** [Request Custom Synthesis Quote](#)

## BenchChem

Our mission is to be the trusted global source of essential and advanced chemicals, empowering scientists and researchers to drive progress in science and industry.

### Contact

Address: 3281 E Guasti Rd  
Ontario, CA 91761, United States  
Phone: (601) 213-4426  
Email: [info@benchchem.com](mailto:info@benchchem.com)

[Contact our Ph.D. Support Team for a compatibility check](#)