

Unveiling the Cellular Targets of EPZ030456: A Technical Guide

Author: BenchChem Technical Support Team. **Date:** April 2026

Compound of Interest

Compound Name: EPZ030456

Cat. No.: B15585474

[Get Quote](#)

For Researchers, Scientists, and Drug Development Professionals

Introduction

EPZ030456 is a potent and selective small molecule inhibitor of the lysine methyltransferase SMYD3 (SET and MYND domain-containing protein 3). Dysregulation of SMYD3 activity has been implicated in the pathogenesis of various cancers, including those of the breast, liver, and colorectum, making it an attractive therapeutic target. This technical guide provides a comprehensive overview of the cellular targets of **EPZ030456**, detailing its mechanism of action, quantitative biochemical and cellular data, and the experimental protocols used for its characterization. The information presented herein is intended to serve as a valuable resource for researchers and drug development professionals working in the field of oncology and epigenetic modulation.

Core Target: SMYD3

The primary cellular target of **EPZ030456** is the enzyme SMYD3. This protein is a member of the SMYD family of lysine methyltransferases, which are characterized by the presence of a catalytic SET domain and a MYND domain involved in protein-protein interactions. SMYD3

catalyzes the transfer of methyl groups from the cofactor S-adenosyl-L-methionine (SAM) to specific lysine residues on both histone and non-histone protein substrates.

Quantitative Data Summary

The inhibitory activity of **EPZ030456** and its more potent analog, EPZ031686, against SMYD3 has been characterized through various biochemical and cellular assays. The following tables summarize the key quantitative data available for these compounds.

Compound	Target	Assay Type	IC50	Reference
EPZ030456	SMYD3	Biochemical	48 nM	[1][2]
EPZ031686	SMYD3	Biochemical	3 nM	[3]

Table 1: Biochemical inhibitory activity of **EPZ030456** and EPZ031686 against SMYD3.

Compound	Cell Line	Assay	Target Substrate	IC50	Reference
EPZ031686	HeLa	Western Blot	MAP3K2-K260 trimethylation	Dose-dependent decrease	[4]

Table 2: Cellular activity of EPZ031686 on a known SMYD3 substrate.

While **EPZ030456** is reported to be a selective inhibitor, a comprehensive public dataset of its activity against a broad panel of other methyltransferases is not currently available.

Signaling Pathways Modulated by EPZ030456

By inhibiting SMYD3, **EPZ030456** can modulate several downstream signaling pathways that are critical for cancer cell proliferation, survival, and migration. SMYD3 has been shown to methylate and regulate the activity of key signaling proteins.

One of the most well-characterized non-histone substrates of SMYD3 is Mitogen-Activated Protein Kinase Kinase Kinase 2 (MAP3K2). SMYD3-mediated trimethylation of MAP3K2 at

lysine 260 enhances its kinase activity, leading to the activation of the Ras/Raf/MEK/ERK signaling cascade. This pathway is a central regulator of cell proliferation and survival.

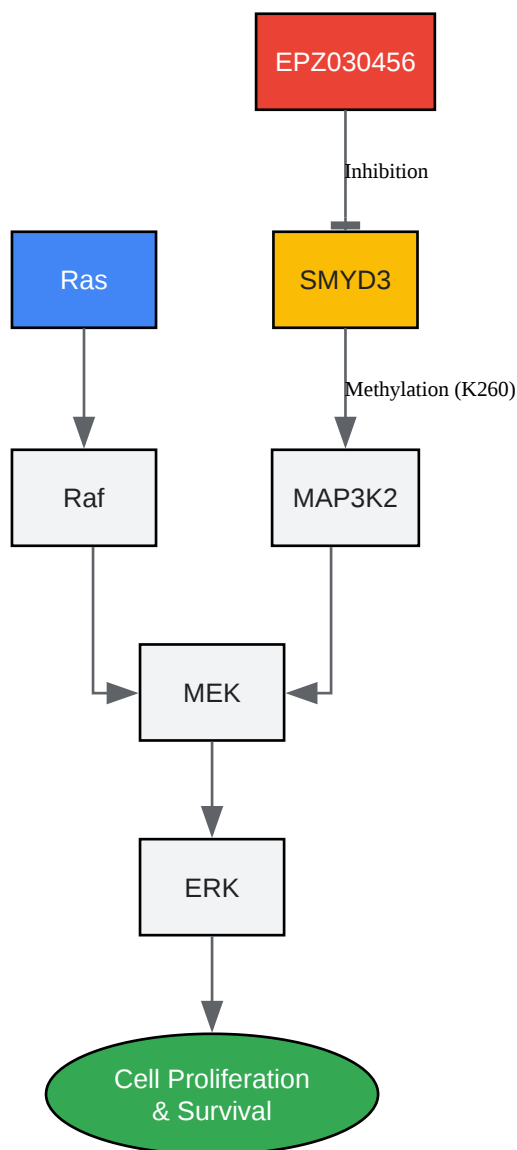

[Click to download full resolution via product page](#)

SMYD3-mediated activation of the MAPK signaling pathway.

SMYD3 also methylates other important signaling molecules, including:

- Vascular Endothelial Growth Factor Receptor 1 (VEGFR1): Methylation enhances its kinase function, promoting angiogenesis.

- Human Epidermal Growth Factor Receptor 2 (HER2): Methylation can lead to its activation, a key driver in some breast cancers.
- AKT1: Methylation of AKT1 is a critical step for its activation, promoting cell survival and growth.

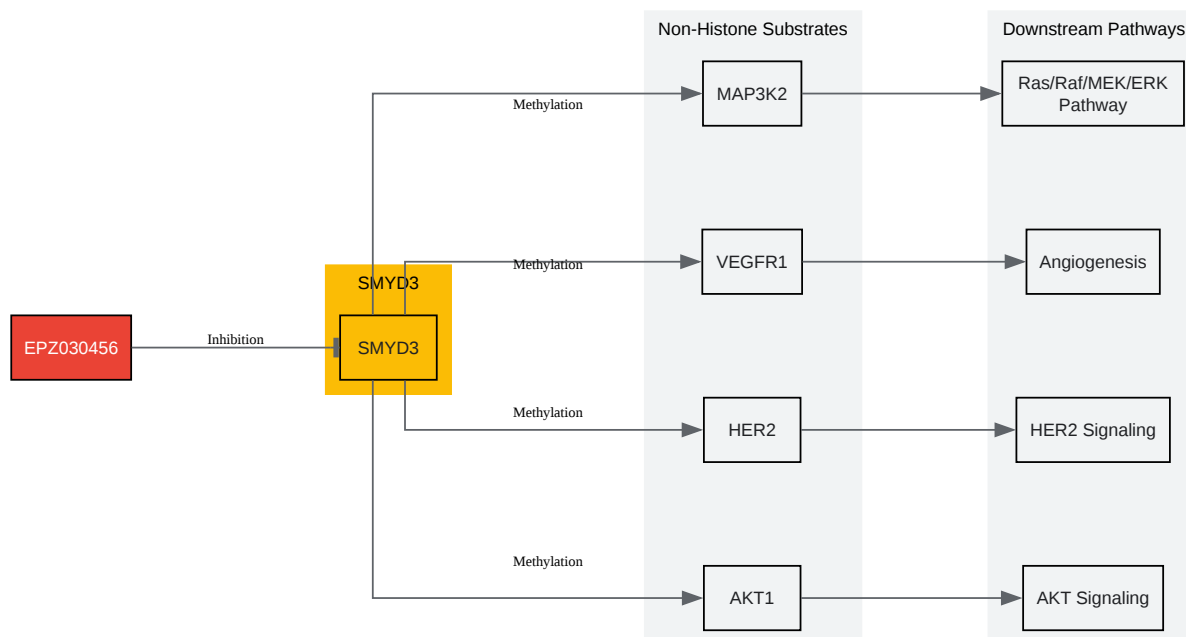

[Click to download full resolution via product page](#)

Overview of key non-histone substrates of SMYD3.

Experimental Protocols

Detailed methodologies are crucial for the replication and validation of scientific findings. Below are representative protocols for key experiments used to characterize SMYD3 inhibitors.

Biochemical Assay for SMYD3 Activity

This in vitro assay measures the enzymatic activity of recombinant SMYD3.

Materials:

- Recombinant human SMYD3 protein
- Histone H3 or recombinant MAP3K2 as substrate
- S-adenosyl-L-[methyl-³H]-methionine (Radiolabeled SAM)
- Assay buffer (e.g., 50 mM Tris-HCl pH 8.5, 5 mM MgCl₂, 4 mM DTT)
- **EPZ030456** or other test compounds
- Scintillation counter and filter plates

Protocol:

- Prepare a reaction mixture containing assay buffer, substrate, and radiolabeled SAM.
- Add varying concentrations of **EPZ030456** or a vehicle control (e.g., DMSO) to the reaction mixture.
- Initiate the reaction by adding recombinant SMYD3 enzyme.
- Incubate the reaction at 30°C for a defined period (e.g., 60 minutes).
- Stop the reaction by adding a quenching buffer (e.g., trichloroacetic acid).
- Transfer the reaction mixture to a filter plate to capture the methylated substrate.
- Wash the filter plate to remove unincorporated radiolabeled SAM.
- Measure the radioactivity on the filter plate using a scintillation counter.
- Calculate the percent inhibition at each compound concentration and determine the IC₅₀ value by fitting the data to a dose-response curve.

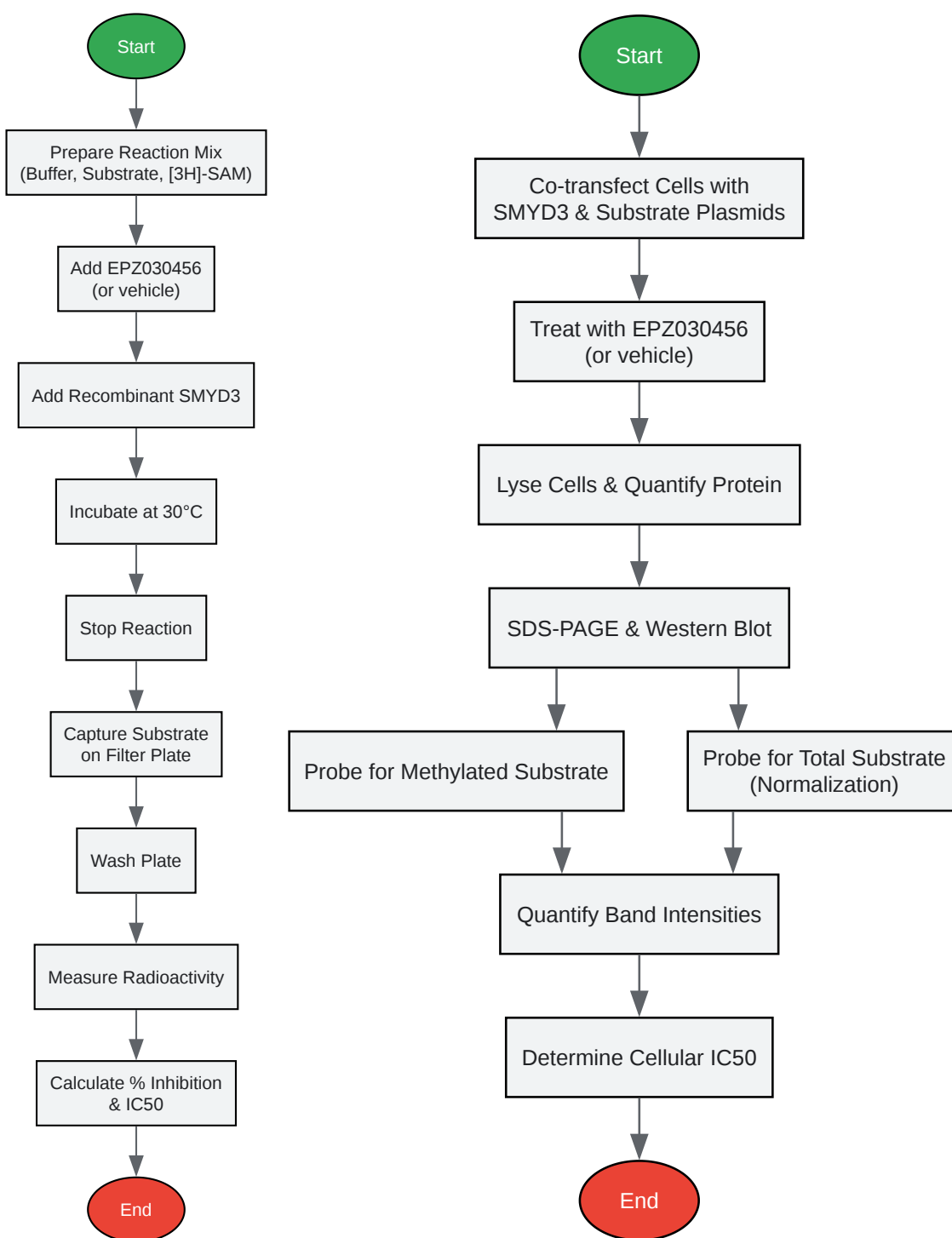

[Click to download full resolution via product page](#)

Need Custom Synthesis?

BenchChem offers custom synthesis for rare earth carbides and specific isotopic labeling.

Email: info@benchchem.com or [Request Quote Online](#).

References

- [1. researchgate.net \[researchgate.net\]](#)
- [2. SMYD3 - Wikipedia \[en.wikipedia.org\]](#)
- [3. Structural Analysis of SMYD3 Lysine Methyltransferase for the Development of Competitive and Specific Enzyme Inhibitors - PMC \[pmc.ncbi.nlm.nih.gov\]](#)
- [4. SMYD3 cellular assay – openlabnotebooks.org \[openlabnotebooks.org\]](#)
- To cite this document: BenchChem. [Unveiling the Cellular Targets of EPZ030456: A Technical Guide]. BenchChem, [2026]. [Online PDF]. Available at: [\[https://www.benchchem.com/product/b15585474/docs#unveiling-the-cellular-targets-of-epz030456-a-technical-guide\]](https://www.benchchem.com/product/b15585474/docs#unveiling-the-cellular-targets-of-epz030456-a-technical-guide)

Disclaimer & Data Validity:

The information provided in this document is for Research Use Only (RUO) and is strictly not intended for diagnostic or therapeutic procedures. While BenchChem strives to provide accurate protocols, we make no warranties, express or implied, regarding the fitness of this product for every specific experimental setup.

Technical Support: The protocols provided are for reference purposes. Unsure if this reagent suits your experiment?

Need Industrial/Bulk Grade? [Request Custom Synthesis Quote](#)

BenchChem

Our mission is to be the trusted global source of essential and advanced chemicals, empowering scientists and researchers to drive progress in science and industry.

Contact

Address: 3281 E Guasti Rd
Ontario, CA 91761, United States
Phone: (601) 213-4426
Email: info@benchchem.com

Contact our Ph.D. Support Team for a compatibility check