

# Technical Guide: Mechanism of Action of LSD1 Inhibitors

**Author:** BenchChem Technical Support Team. **Date:** April 2026

## Compound of Interest

Compound Name: *Lsd1-IN-37*

Cat. No.: *B15585018*

[Get Quote](#)

A Note on **Lsd1-IN-37**: Publicly available scientific literature and databases do not contain specific information on a compound designated "**Lsd1-IN-37**." Therefore, this technical guide will provide a comprehensive overview of the mechanism of action of well-characterized Lysine-Specific Demethylase 1 (LSD1) inhibitors, using publicly available data for representative compounds as illustrative examples. The principles, experimental methodologies, and signaling pathways described herein are broadly applicable to the study of novel LSD1 inhibitors.

## Introduction to Lysine-Specific Demethylase 1 (LSD1)

Lysine-Specific Demethylase 1 (LSD1), also known as KDM1A, is a flavin adenine dinucleotide (FAD)-dependent amine oxidase that plays a crucial role in epigenetic regulation.[1][2][3] It primarily removes methyl groups from mono- and di-methylated lysine 4 of histone H3 (H3K4me1/2), a mark associated with active gene transcription.[4][5][6] By demethylating H3K4, LSD1 generally acts as a transcriptional co-repressor.[2][4] LSD1 is a key component of several large protein complexes, including the CoREST and NuRD complexes, which are involved in gene silencing.[1][2][7]

In addition to its role in histone modification, LSD1 can also demethylate non-histone substrates, such as p53, DNMT1, and STAT3, thereby regulating their activity and stability.<sup>[3][4]</sup> LSD1 is overexpressed in a variety of cancers, including acute myeloid leukemia (AML), small cell lung cancer (SCLC), prostate cancer, and neuroblastoma, making it an attractive therapeutic target.<sup>[2][4]</sup> Inhibition of LSD1 has been shown to induce differentiation, inhibit proliferation, and promote cell death in cancer cells.<sup>[4][8]</sup>

## Core Mechanism of Action of LSD1 Inhibitors

The primary mechanism of action of LSD1 inhibitors is the blockade of its demethylase activity. This leads to an accumulation of H3K4me1/2 at target gene promoters, which in turn alters gene expression. The downstream effects of LSD1 inhibition are context-dependent and can include:

- **Induction of Cellular Differentiation:** In many cancer types, such as AML, LSD1 inhibition leads to the upregulation of myeloid-lineage markers like CD11b and CD86, promoting differentiation and reducing the population of leukemic stem cells.<sup>[4]</sup>
- **Inhibition of Cell Proliferation and Viability:** By altering the expression of genes involved in cell cycle control and survival, LSD1 inhibitors can reduce the proliferative capacity of cancer cells.<sup>[2][7]</sup>
- **Modulation of Signaling Pathways:** LSD1 has been shown to regulate key signaling pathways involved in cancer progression. For instance, in prostate cancer, LSD1 can activate the PI3K/AKT pathway by regulating the expression of the p85 subunit.<sup>[9]</sup>
- **Suppression of Epithelial-Mesenchymal Transition (EMT):** Some LSD1 inhibitors have been shown to suppress EMT, a process crucial for cancer cell migration and metastasis, by increasing the expression of epithelial markers like E-cadherin and decreasing mesenchymal markers like N-cadherin and Vimentin.<sup>[10]</sup>

LSD1 inhibitors can be broadly classified into two categories based on their mechanism of binding:

- **Irreversible Inhibitors:** These are typically mechanism-based inactivators that form a covalent bond with the FAD cofactor of LSD1. Many of these are derivatives of tranylcypromine (TCP).

- Reversible Inhibitors: These inhibitors bind non-covalently to the active site of LSD1.

## Quantitative Data on Representative LSD1 Inhibitors

The following tables summarize the in vitro activity of several well-characterized LSD1 inhibitors against LSD1 and other related enzymes.

Table 1: Biochemical Activity of Selected LSD1 Inhibitors

Compound	LSD1 IC50 (nM)	MAO-A IC50 (μM)	MAO-B IC50 (μM)	Reversibility	Reference
Compound 14	180	>1	>1	Reversible	[10]
Seclidemstat	-	-	-	-	[10]
TCP	-	2.84	0.73	Irreversible	[1]
PLZ	-	0.42	0.83	-	[1]
PRG	-	3.84	0.24	-	[1]

Data for Seclidemstat was not explicitly provided in the search results in a comparable format.

Table 2: Cellular Activity of Selected LSD1 Inhibitors

Compound	Cell Line	Assay Type	IC50 (μM)	Reference
Compound 14	HepG2	Antiproliferative	0.93	[10]
Compound 14	HEP3B	Antiproliferative	2.09	[10]
Compound 14	HUH6	Antiproliferative	1.43	[10]
Compound 14	HUH7	Antiproliferative	4.37	[10]
CC-90011	TC-32	Cell Viability	-	[11]
SP-2577	TC-32	Cell Viability	-	[11]

Specific IC50 values for CC-90011 and SP-2577 in TC-32 cells were not provided in the search results.

## Detailed Experimental Protocols

### LSD1 Demethylase Activity/Inhibition Assay (Colorimetric)

This protocol is based on the general principles of an antibody-based, immunospecific method to directly measure LSD1 activity.[\[12\]](#)

Principle: A di-methylated histone H3K4 substrate is coated onto microplate wells. Active LSD1 is added, and it removes methyl groups from the substrate. The demethylated product is then detected by a specific antibody, and the signal is quantified colorimetrically.

Materials:

- 96-well microplate coated with di-methylated H3K4 substrate
- Purified LSD1 enzyme or nuclear extracts
- LSD1 inhibitor (test compound)
- Assay buffer
- Capture antibody (anti-unmethylated H3K4)
- Detection antibody (HRP-conjugated)
- HRP substrate
- Stop solution
- Plate reader

Procedure:

- **Prepare Assay Solutions:** Dilute the LSD1 enzyme and test inhibitor to the desired concentrations in assay buffer.
- **Enzyme Reaction:** Add the diluted LSD1 enzyme and inhibitor to the substrate-coated wells.
- **Incubation:** Incubate the plate at 37°C for a specified time (e.g., 60-120 minutes) to allow the demethylation reaction to occur.
- **Washing:** Wash the wells multiple times with a wash buffer to remove unbound enzyme and inhibitors.
- **Capture Antibody:** Add the capture antibody to each well and incubate at room temperature to allow binding to the demethylated substrate.
- **Washing:** Repeat the washing step.
- **Detection Antibody:** Add the HRP-conjugated detection antibody and incubate.
- **Washing:** Repeat the washing step.
- **Signal Development:** Add the HRP substrate and incubate until a color develops.
- **Stop Reaction:** Add the stop solution to quench the reaction.
- **Measurement:** Read the absorbance at the appropriate wavelength using a microplate reader.
- **Data Analysis:** Calculate the percentage of LSD1 inhibition by comparing the absorbance of the inhibitor-treated wells to the control (no inhibitor) wells.

## Cell Viability Assay (CellTiter-Glo®)

This protocol is a common method for assessing the effect of a compound on cell viability.<sup>[7][8]</sup>

**Principle:** The CellTiter-Glo® assay measures the amount of ATP present, which is an indicator of metabolically active cells. A decrease in ATP levels corresponds to a decrease in cell viability.

**Materials:**

- Cancer cell lines of interest
- Cell culture medium and supplements
- 384-well plates
- LSD1 inhibitor (test compound)
- CellTiter-Glo® Reagent
- Luminometer

**Procedure:**

- **Cell Seeding:** Seed cells into 384-well plates at a predetermined density (e.g.,  $4.5 \times 10^3$  cells per well) and incubate for 24 hours to allow for attachment and logarithmic growth.<sup>[7]</sup>
- **Compound Treatment:** Add serial dilutions of the LSD1 inhibitor to the wells. Include a vehicle control (e.g., DMSO).
- **Incubation:** Incubate the plates for a specified period (e.g., 72 hours) at 37°C and 5% CO<sub>2</sub>.<sup>[7]</sup>
- **Assay Reagent Addition:** Equilibrate the plate and the CellTiter-Glo® reagent to room temperature. Add the reagent to each well.
- **Signal Stabilization:** Mix the contents of the wells to induce cell lysis and incubate at room temperature to stabilize the luminescent signal.
- **Measurement:** Read the luminescence using a luminometer.
- **Data Analysis:** Calculate the percentage of cell viability relative to the vehicle control. Determine the IC<sub>50</sub> value, which is the concentration of the inhibitor that causes a 50% reduction in cell viability.

## Visualizations

## LSD1 Mechanism of Action

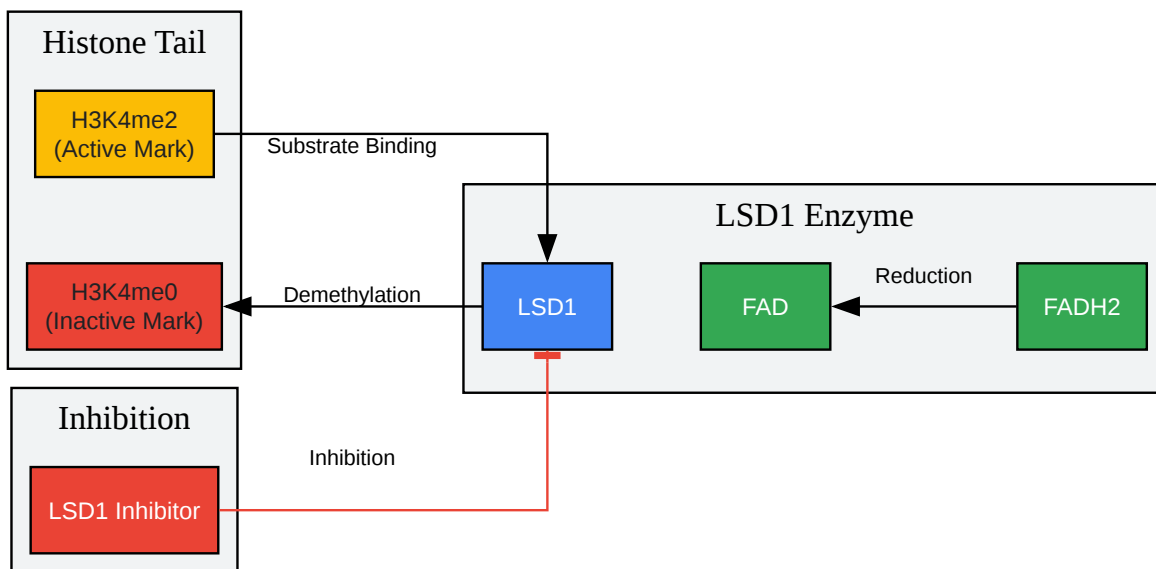

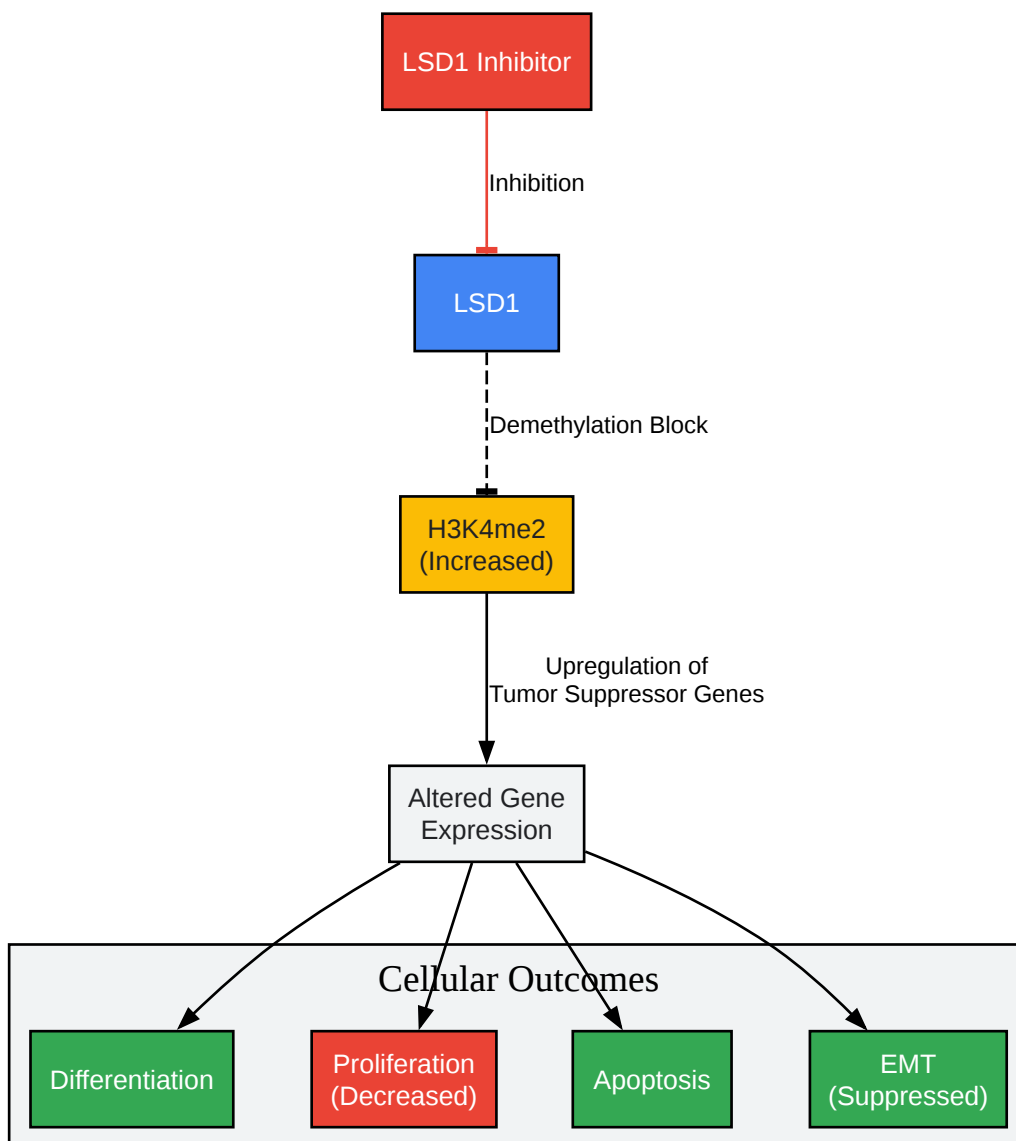

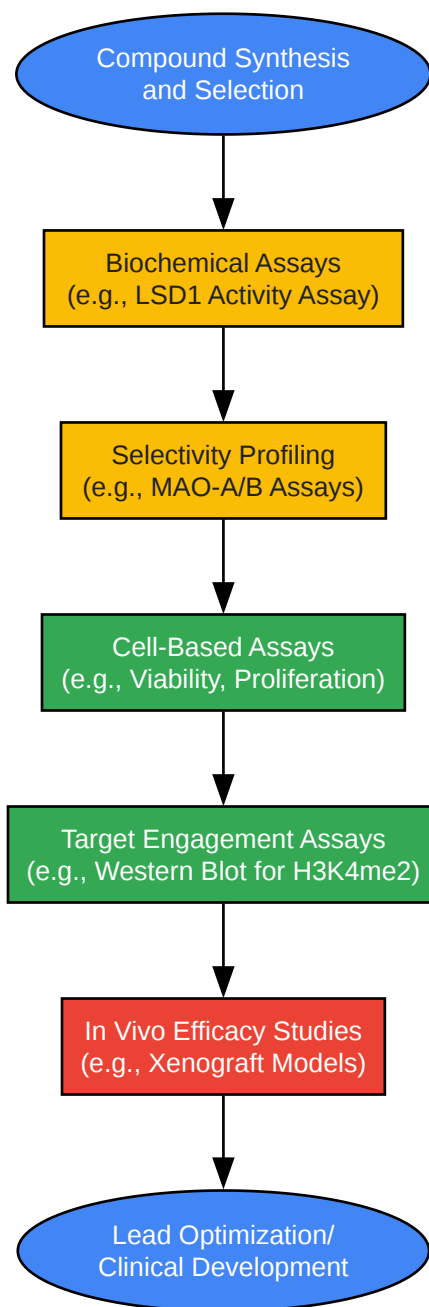

[Click to download full resolution via product page](#)

### Need Custom Synthesis?

BenchChem offers custom synthesis for rare earth carbides and specific isotopic labeling.

Email: [info@benchchem.com](mailto:info@benchchem.com) or [Request Quote Online](#).

## References

- [1. researchgate.net \[researchgate.net\]](https://www.researchgate.net)
- [2. Comprehensive in Vitro Characterization of the LSD1 Small Molecule Inhibitor Class in Oncology - PMC \[pmc.ncbi.nlm.nih.gov\]](https://pubmed.ncbi.nlm.nih.gov/)
- [3. Anti-Proliferative Effect of Potential LSD1/CoREST Inhibitors Based on Molecular Dynamics Model for Treatment of SH-SY5Y Neuroblastoma Cancer Cell Line - PMC \[pmc.ncbi.nlm.nih.gov\]](https://pubmed.ncbi.nlm.nih.gov/)
- [4. LSD1 inhibitors for cancer treatment: Focus on multi-target agents and compounds in clinical trials - PMC \[pmc.ncbi.nlm.nih.gov\]](https://pubmed.ncbi.nlm.nih.gov/)
- [5. LSD1 and The Chemistry of Histone Demethylation - PMC \[pmc.ncbi.nlm.nih.gov\]](https://pubmed.ncbi.nlm.nih.gov/)
- [6. LSD1 Histone Demethylase Assays and Inhibition - PubMed \[pubmed.ncbi.nlm.nih.gov\]](https://pubmed.ncbi.nlm.nih.gov/)
- [7. Small molecule inhibition of lysine-specific demethylase 1 \(LSD1\) and histone deacetylase \(HDAC\) alone and in combination in Ewing sarcoma cell lines - PMC \[pmc.ncbi.nlm.nih.gov\]](https://pubmed.ncbi.nlm.nih.gov/)
- [8. LSD1 inhibition induces differentiation and cell death in Merkel cell carcinoma - PMC \[pmc.ncbi.nlm.nih.gov\]](https://pubmed.ncbi.nlm.nih.gov/)
- [9. LSD1 Activates PI3K/AKT Signaling Through Regulating p85 Expression in Prostate Cancer Cells - PMC \[pmc.ncbi.nlm.nih.gov\]](https://pubmed.ncbi.nlm.nih.gov/)
- [10. Discovery of a selective and reversible LSD1 inhibitor with potent anticancer effects in vitro and in vivo - PMC \[pmc.ncbi.nlm.nih.gov\]](https://pubmed.ncbi.nlm.nih.gov/)
- [11. Anticancer Drugs of Lysine Specific Histone Demethylase-1 \(LSD1\) Display Variable Inhibition on Nucleosome Substrates - PMC \[pmc.ncbi.nlm.nih.gov\]](https://pubmed.ncbi.nlm.nih.gov/)
- [12. Epigenase LSD1 Demethylase Activity/Inhibition Assay Kit \(Colorimetric\) | EpigenTek \[epigentek.com\]](https://www.epigentek.com/)
- To cite this document: BenchChem. [Technical Guide: Mechanism of Action of LSD1 Inhibitors]. BenchChem, [2026]. [Online PDF]. Available at: [\[https://www.benchchem.com/product/b15585018/docs#technical-guide-mechanism-of-action-of-lsd1-inhibitors\]](https://www.benchchem.com/product/b15585018/docs#technical-guide-mechanism-of-action-of-lsd1-inhibitors)

---

### Disclaimer & Data Validity:

The information provided in this document is for Research Use Only (RUO) and is strictly not intended for diagnostic or therapeutic procedures. While BenchChem strives to provide accurate protocols, we make no warranties, express or implied, regarding the fitness of this product for every specific experimental setup.

**Technical Support:** The protocols provided are for reference purposes. Unsure if this reagent suits your experiment?

**Need Industrial/Bulk Grade?** [Request Custom Synthesis Quote](#)

## BenchChem

Our mission is to be the trusted global source of essential and advanced chemicals, empowering scientists and researchers to drive progress in science and industry.

### Contact

Address: 3281 E Guasti Rd  
Ontario, CA 91761, United States  
Phone: (601) 213-4426  
Email: [info@benchchem.com](mailto:info@benchchem.com)

[Contact our Ph.D. Support Team for a compatibility check](#)