

A Comparative Guide to Current Small Molecule Inhibitors of NSD2

Author: BenchChem Technical Support Team. **Date:** April 2026

Compound of Interest

Compound Name: LEM-14
Cat. No.: B15585039

[Get Quote](#)

For Researchers, Scientists, and Drug Development Professionals

The nuclear receptor-binding SET domain protein 2 (NSD2), also known as MMSET or WHSC1, has emerged as a critical epigenetic regulator and a promising therapeutic target in oncology.[1][2][3] Dysregulation of NSD2, often through genetic translocations, amplifications, or mutations, is a key driver in various cancers, including multiple myeloma, acute lymphoblastic leukemia, and certain solid tumors.[1][4][5] NSD2 is a histone methyltransferase that primarily catalyzes the dimethylation of histone H3 at lysine 36 (H3K36me2), a modification associated with active gene transcription.[6][7][8] The aberrant activity of NSD2 leads to a cascade of downstream effects, promoting oncogenesis and therapeutic resistance.[9][10] This has spurred the development of small molecule inhibitors aimed at curtailing its pathogenic activity.

This guide provides a comparative overview of current small molecule inhibitors and degraders of NSD2, presenting key experimental data, detailed methodologies for cited experiments, and visualizations of relevant signaling pathways to aid researchers in this rapidly evolving field.

Comparative Analysis of NSD2 Inhibitors and Degraders

The landscape of NSD2-targeted therapeutics includes both direct enzymatic inhibitors and proteolysis-targeting chimeras (PROTACs) designed to induce its degradation. The following table summarizes the quantitative data for some of the most notable compounds.

Compound	Type	Target Domain	IC50/DC50	Binding Affinity (Kd)	Cellular Activity	Selectivity	Clinical Status
KTX-1001 (Gintemostat)	Inhibitor	SET Domain	IC50: 1-10 nM[2]; 2.3 nM (biochemical)[11]; 16.0 nM[12]	~6-70 nM (to SET domain) [11]	Reduces H3K36me2 in KMS11/BTZ cells. [13]	Highly selective for NSD2 over 25 other histone methyltransferases.[12]	Phase 1 (NCT05651932) for relapsed/refractory multiple myeloma. [1][5][14]
KTX-2001	Inhibitor	SET Domain	Preclinical data not fully disclosed.	Not disclosed.	Reduces H3K36me2, suppresses oncogenic transcription, and inhibits tumor cell proliferation in preclinical prostate cancer models. [15]	Potent and selective. [15][16]	Phase 1 (STRIKE-001, NCT07103018) for metastatic castration-resistant prostate cancer. [14][17]
W4275 (Compound 42)	Inhibitor	SET Domain	IC50: 17 nM[18]	Not disclosed.	Antiproliferative. IC50: 230 nM	Selective for NSD2. [18]	Preclinical.

					in RS411 cells.[18]		
RK-552	Inhibitor	Not specified	Not disclosed	Not disclosed	Cytotoxic to t(4;14)+ multiple myeloma cells.[19]	Inhibits NSD2 but not G9a or SET7/9.[19][20]	Preclinical.
UNC8153	Degrader (PROTAC)	PWWP1 Domain	DC50: 350 nM (in U2OS cells)[1][17][21]; 3.41 μM (in KMS11 cells)[22]	24 nM[1][21][23]	Reduces cellular levels of NSD2 and H3K36me2; exhibits anti-adhesion effects in KMS11 cells and mild antiproliferative effects in MM1.S cells.[22][23]	Selective for NSD2 over NSD1 and NSD3.[17]	Preclinical.
LLC0424	Degrader (PROTAC)	Not specified	DC50: 20 nM (in RPMI-8402 cells)[4][6][24][25][26][27]	Not disclosed	Antiproliferative IC50: 0.56 μM (RPMI-8402), 3.56 μM (SEM).	Selective for NSD2; does not degrade NSD1, NSD3, or common	Preclinical.

[24] CRBN
Potent in neosubst
vivo rates.[6]
degradati
on.[4][6]
[25]

Key Experimental Protocols

The characterization of NSD2 inhibitors relies on a variety of biochemical and cellular assays. Below are detailed methodologies for key experiments frequently cited in the literature.

Biochemical Enzyme Inhibition Assay (AlphaLISA)

This high-throughput assay is commonly used to screen for and characterize inhibitors of NSD2's methyltransferase activity by detecting the product of the enzymatic reaction, H3K36me2.

Principle: The assay utilizes AlphaLISA (Amplified Luminescent Proximity Homogeneous Assay) technology. An anti-H3K36me2 antibody is conjugated to an AlphaLISA acceptor bead, and a biotinylated anti-Histone H3 antibody is captured by a streptavidin-coated donor bead. In the presence of H3K36me2 on a histone substrate (peptide, nucleosome), the beads are brought into proximity. Upon excitation of the donor bead at 680 nm, singlet oxygen is generated, which diffuses to the acceptor bead, triggering a chemiluminescent signal at 615 nm. The signal intensity is proportional to the amount of H3K36me2.

Protocol:

- **Reaction Setup:** In a 384-well plate, combine the NSD2 enzyme, a histone H3 substrate (e.g., recombinant nucleosomes), and the methyl donor S-adenosylmethionine (SAM) in an appropriate reaction buffer.
- **Compound Addition:** Add the test compound (potential inhibitor) at various concentrations. Include a positive control (no inhibitor) and a negative control (no enzyme).
- **Enzymatic Reaction:** Incubate the plate at a controlled temperature (e.g., 30°C) for a specific duration (e.g., 60 minutes) to allow the methylation reaction to proceed.

- Detection:
 - Stop the reaction by adding a solution containing AlphaLISA anti-H3K36me2 acceptor beads and biotinylated anti-Histone H3 (C-terminus) antibody.[\[28\]](#)[\[29\]](#)
 - Incubate to allow for antibody-antigen binding.
 - Add streptavidin-coated donor beads.[\[28\]](#)[\[29\]](#)
 - Incubate in the dark to allow for bead proximity binding.
- Signal Reading: Read the plate on an Alpha-enabled microplate reader.
- Data Analysis: Calculate the percent inhibition for each compound concentration relative to the controls and determine the IC50 value by fitting the data to a dose-response curve.

Cellular H3K36me2 Quantification Assay (Cellular AlphaLISA)

This assay measures the levels of H3K36me2 within cells after treatment with an NSD2 inhibitor.[\[28\]](#)[\[30\]](#)

Protocol:

- Cell Culture and Treatment: Plate cells in a 96- or 384-well plate and culture overnight. Treat the cells with the NSD2 inhibitor at various concentrations for a desired period (e.g., 24-72 hours).
- Cell Lysis and Histone Extraction:
 - Remove the culture medium.
 - Add Cell-Histone Lysis Buffer and incubate to lyse the cells.[\[28\]](#)
 - Add Cell-Histone Extraction Buffer to release histones from the DNA.[\[28\]](#)
- AlphaLISA Detection:

- Transfer the histone-containing lysate to a new assay plate.
- Add a mixture of AlphaLISA anti-H3K36me2 acceptor beads and biotinylated anti-Histone H3 antibody.
- Incubate to allow for binding.
- Add streptavidin-coated donor beads and incubate in the dark.
- Signal Reading and Analysis: Read the plate and analyze the data as described for the biochemical assay to determine the effect of the inhibitor on cellular H3K36me2 levels.

PROTAC-Mediated Protein Degradation Assay (Western Blot)

This method is used to confirm the degradation of the target protein (NSD2) following treatment with a PROTAC degrader.

Protocol:

- Cell Treatment: Treat cells with the PROTAC degrader at various concentrations and for different time points.
- Cell Lysis: Harvest the cells and lyse them in a suitable lysis buffer containing protease inhibitors to extract total cellular proteins.
- Protein Quantification: Determine the protein concentration of each lysate using a standard method (e.g., BCA assay).
- SDS-PAGE and Western Blot:
 - Separate equal amounts of protein from each sample by sodium dodecyl sulfate-polyacrylamide gel electrophoresis (SDS-PAGE).
 - Transfer the separated proteins to a nitrocellulose or PVDF membrane.
 - Block the membrane with a blocking buffer (e.g., 5% non-fat milk in TBST) to prevent non-specific antibody binding.

- Incubate the membrane with a primary antibody specific for NSD2. A loading control antibody (e.g., anti-GAPDH or anti- β -actin) should also be used to ensure equal protein loading.
- Wash the membrane and incubate with a horseradish peroxidase (HRP)-conjugated secondary antibody.
- Wash the membrane again and detect the protein bands using an enhanced chemiluminescence (ECL) substrate and an imaging system.
- Data Analysis: Quantify the band intensities for NSD2 and the loading control. Normalize the NSD2 signal to the loading control and compare the levels in treated samples to the untreated control to determine the extent of degradation. Calculate the DC50 (concentration at which 50% degradation is observed).

NSD2-Associated Signaling Pathways

NSD2's influence on cancer extends through its modulation of several key signaling pathways. Understanding these connections is crucial for elucidating the mechanism of action of NSD2 inhibitors and identifying potential combination therapies.

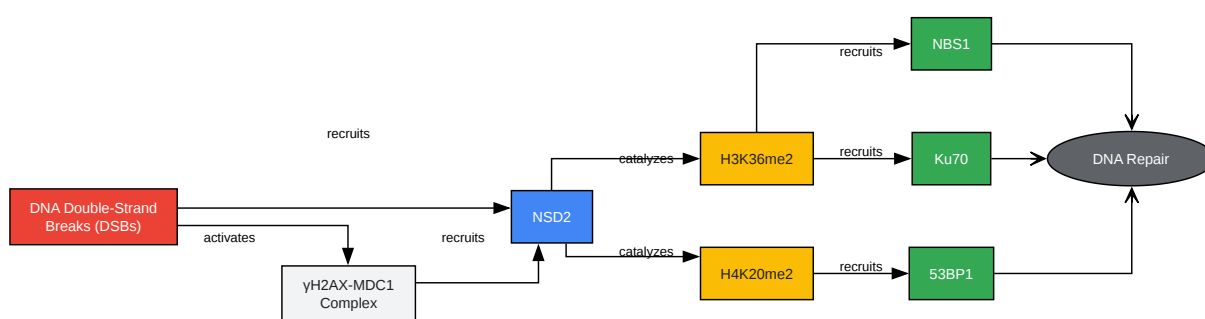

[Click to download full resolution via product page](#)

NSD2's Role in the DNA Damage Response Pathway.

NSD2 is recruited to sites of DNA double-strand breaks (DSBs) where it promotes the deposition of H3K36me2.[7] This histone mark facilitates the recruitment of DNA repair proteins such as NBS1 and Ku70.[3] Additionally, NSD2 is involved in the γ H2AX-MDC1 signaling pathway, leading to H4K20 methylation and the subsequent recruitment of 53BP1 to the damage site, ultimately promoting DNA repair.[7][9]

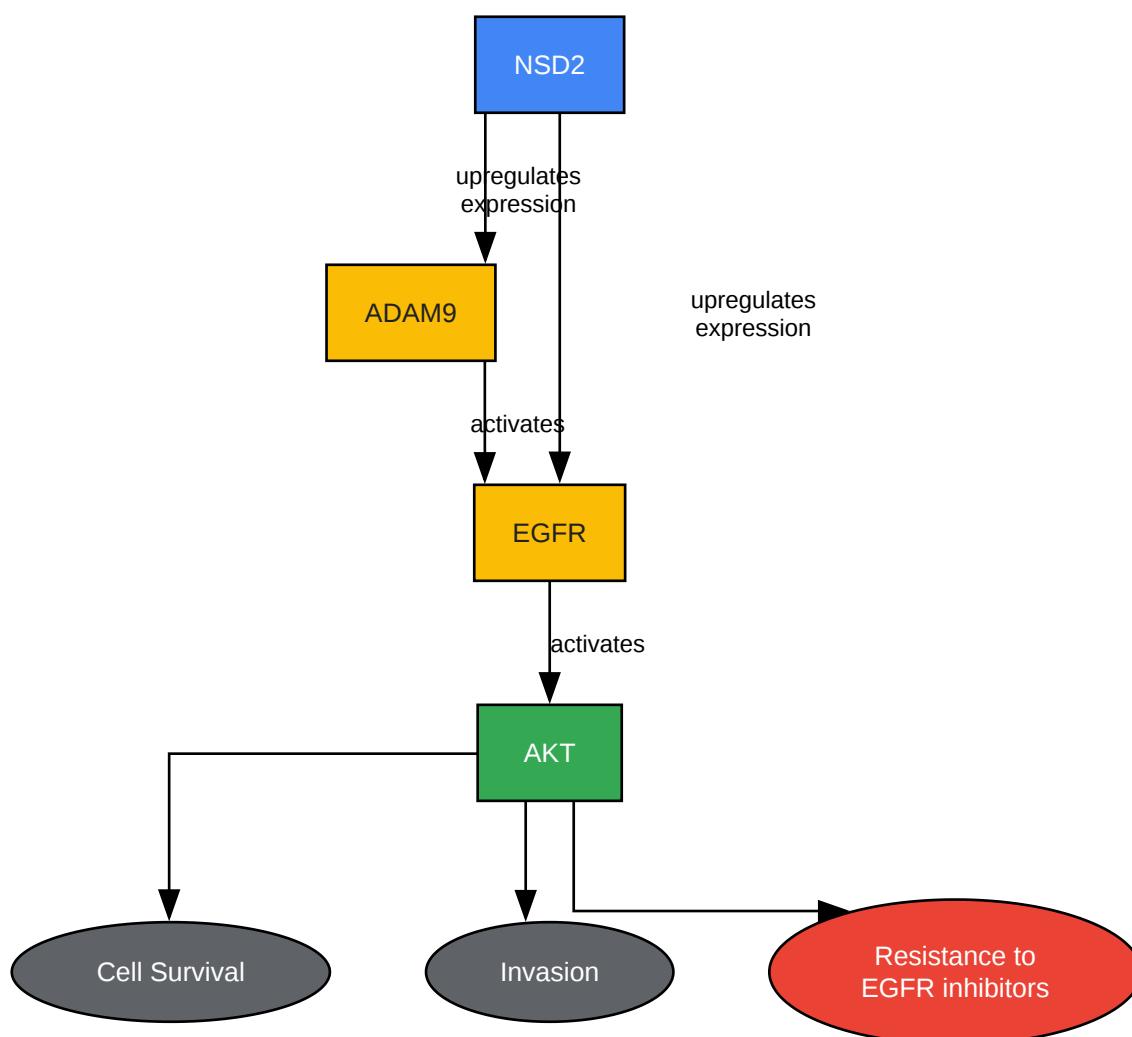

[Click to download full resolution via product page](#)

NSD2-Mediated Activation of the EGFR-AKT Pathway.

In triple-negative breast cancer, NSD2 has been shown to upregulate the expression of both ADAM9 and the epidermal growth factor receptor (EGFR).[10] ADAM9 can proteolytically cleave and release EGFR ligands, leading to the activation of EGFR and its downstream

effector, AKT.[10] This signaling cascade promotes cell survival, invasion, and resistance to EGFR inhibitors.[8][9][10]

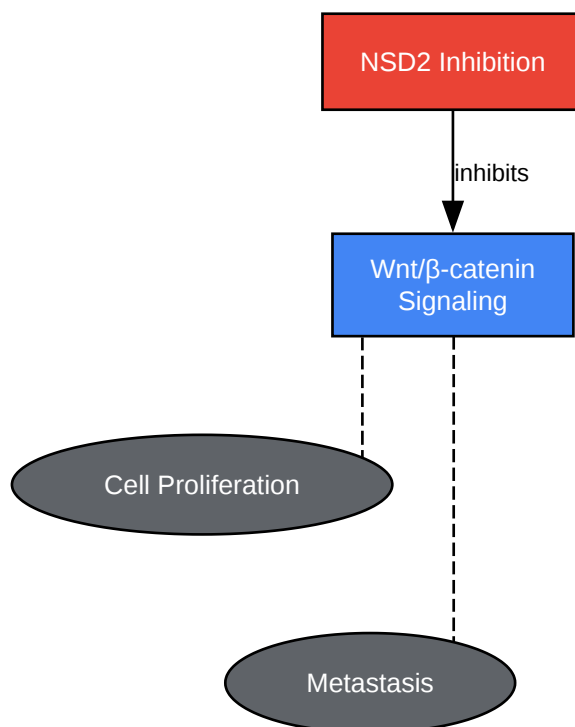

[Click to download full resolution via product page](#)

Inhibition of Wnt/β-catenin Pathway by NSD2 Silencing.

The silencing of NSD2 has been demonstrated to inhibit the Wnt/β-catenin signaling pathway. [8][9] This inhibition leads to a marked decrease in cell proliferation and metastasis in certain cancer models, highlighting another important oncogenic pathway influenced by NSD2.[8][9]

Conclusion

The development of small molecule inhibitors and degraders targeting NSD2 represents a promising frontier in precision oncology. The compounds highlighted in this guide, from the clinically advancing KTX-1001 to potent preclinical degraders like LLC0424, showcase the diverse strategies being employed to drug this critical epigenetic regulator. The provided experimental protocols and pathway diagrams offer a foundational resource for researchers aiming to contribute to this exciting field. As our understanding of NSD2's role in cancer deepens, these and future targeted therapies hold the potential to significantly improve outcomes for patients with NSD2-driven malignancies.

Need Custom Synthesis?

BenchChem offers custom synthesis for rare earth carbides and specific isotopic labeling.

Email: info@benchchem.com or [Request Quote Online](#).

References

- [1. medchemexpress.com \[medchemexpress.com\]](https://www.medchemexpress.com)
- [2. Gintemetostat | NSD2 Inhibitor | TargetMol \[targetmol.com\]](https://www.targetmol.com)
- [3. researchgate.net \[researchgate.net\]](https://www.researchgate.net)
- [4. pubs.acs.org \[pubs.acs.org\]](https://pubs.acs.org)
- [5. Drug Discovery Targeting Nuclear Receptor Binding SET Domain Protein 2 \(NSD2\) - PMC \[pmc.ncbi.nlm.nih.gov\]](https://pubmed.ncbi.nlm.nih.gov)
- [6. LLC0424 | NSD2 degrader | Probechem Biochemicals \[probechem.com\]](https://www.probechem.com)
- [7. The role of NSD1, NSD2, and NSD3 histone methyltransferases in solid tumors - PMC \[pmc.ncbi.nlm.nih.gov\]](https://pubmed.ncbi.nlm.nih.gov)
- [8. dovepress.com \[dovepress.com\]](https://www.dovepress.com)
- [9. The Role of Methyltransferase NSD2 as a Potential Oncogene in Human Solid Tumors - PMC \[pmc.ncbi.nlm.nih.gov\]](https://pubmed.ncbi.nlm.nih.gov)
- [10. Histone methyltransferase NSD2 mediates the survival and invasion of triple-negative breast cancer cells via stimulating ADAM9-EGFR-AKT signaling - PMC \[pmc.ncbi.nlm.nih.gov\]](https://pubmed.ncbi.nlm.nih.gov)
- [11. ashpublications.org \[ashpublications.org\]](https://www.ashpublications.org)
- [12. researchgate.net \[researchgate.net\]](https://www.researchgate.net)
- [13. gintemetostat \(KTX-1001\) / K36 Therap, Novartis \[delta.larvol.com\]](https://www.delta.larvol.com)
- [14. urologytimes.com \[urologytimes.com\]](https://www.urologytimes.com)
- [15. k36tx.com \[k36tx.com\]](https://www.k36tx.com)
- [16. firstwordpharma.com \[firstwordpharma.com\]](https://www.firstwordpharma.com)
- [17. caymanchem.com \[caymanchem.com\]](https://www.caymanchem.com)
- [18. medchemexpress.com \[medchemexpress.com\]](https://www.medchemexpress.com)
- [19. ashpublications.org \[ashpublications.org\]](https://www.ashpublications.org)

- 20. [PDF] Histone methyltransferase NSD2 mediates the survival and invasion of triple-negative breast cancer cells via stimulating ADAM9-EGFR-AKT signaling | Semantic Scholar [semanticscholar.org]
- 21. file.medchemexpress.com [file.medchemexpress.com]
- 22. Discovery of a Potent and Selective Targeted NSD2 Degrader for the Reduction of H3K36me2 - PMC [pmc.ncbi.nlm.nih.gov]
- 23. UNC8153 | NSD2 PROTAC | Probechem Biochemicals [probechem.com]
- 24. medchemexpress.com [medchemexpress.com]
- 25. Discovery of LLC0424 as a Potent and Selective in Vivo NSD2 PROTAC Degrader - PubMed [pubmed.ncbi.nlm.nih.gov]
- 26. medchemexpress.com [medchemexpress.com]
- 27. Discovery of LLC0424 as a Potent and Selective in Vivo NSD2 PROTAC Degrader - PMC [pmc.ncbi.nlm.nih.gov]
- 28. resources.revivity.com [resources.revivity.com]
- 29. revivity.com [revivity.com]
- 30. Development of Multiple Cell-Based Assays for the Detection of Histone H3 Lys27 Trimethylation (H3K27me3) - PMC [pmc.ncbi.nlm.nih.gov]
- To cite this document: BenchChem. [A Comparative Guide to Current Small Molecule Inhibitors of NSD2]. BenchChem, [2026]. [Online PDF]. Available at: [https://www.benchchem.com/product/b15585039/docs#a-comparative-guide-to-current-small-molecule-inhibitors-of-nsd2]

Disclaimer & Data Validity:

The information provided in this document is for Research Use Only (RUO) and is strictly not intended for diagnostic or therapeutic procedures. While BenchChem strives to provide accurate protocols, we make no warranties, express or implied, regarding the fitness of this product for every specific experimental setup.

Technical Support: The protocols provided are for reference purposes. Unsure if this reagent suits your experiment?

Need Industrial/Bulk Grade? [Request Custom Synthesis Quote](#)

BenchChem

Our mission is to be the trusted global source of essential and advanced chemicals, empowering scientists and researchers to drive progress in science and industry.

Contact

Address: 3281 E Guasti Rd

Ontario, CA 91761, United States

Phone: (601) 213-4426

Email: info@benchchem.com

[Contact our Ph.D. Support Team for a compatibility check](#)