

# The Pharmacological Profile of Ebio3: A Technical Guide

**Author:** BenchChem Technical Support Team. **Date:** December 2025

## Compound of Interest

Compound Name: *Ebio3*

Cat. No.: *B15584473*

[Get Quote](#)

For Researchers, Scientists, and Drug Development Professionals

This technical guide provides an in-depth overview of the pharmacological profile of **Ebio3**, a novel small-molecule modulator of the voltage-gated potassium channel KCNQ2. This document details its mechanism of action, quantitative pharmacological data, and the experimental protocols used for its characterization.

## Introduction to Ebio3

**Ebio3** is a potent and selective inhibitor of the KCNQ2 (Kv7.2) potassium channel.<sup>[1][2]</sup> It shares a chemical scaffold with Ebio2, which, in contrast, acts as an activator of the same channel. The unique inhibitory action of **Ebio3** on KCNQ2 channels, which are crucial for regulating neuronal excitability, makes it a valuable research tool and a potential therapeutic agent for neurological disorders associated with KCNQ2 gain-of-function mutations.

## Mechanism of Action: Non-Blocking Inhibition

**Ebio3** exhibits a novel, non-blocking mechanism of inhibition. Unlike traditional pore blockers, **Ebio3** binds to a site on the outside of the inner gate of the KCNQ2 channel. This binding event induces a conformational change that directly squeezes the S6 pore helix, leading to the inactivation of the channel. This allosteric modulation provides a distinct approach to ion channel inhibition.

## Signaling and Interaction Pathway

The following diagram illustrates the inhibitory mechanism of **Ebio3** on the KCNQ2 channel.

Ebio3 Mechanism of Action on KCNQ2 Channel

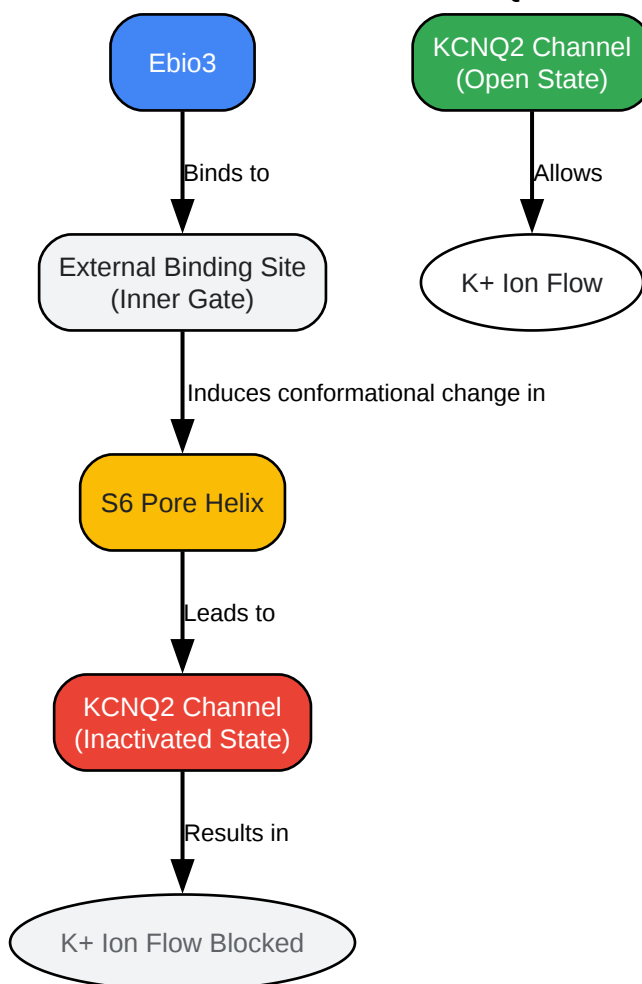

[Click to download full resolution via product page](#)

Caption: **Ebio3**'s non-blocking inhibitory pathway on the KCNQ2 channel.

## Quantitative Pharmacological Data

The inhibitory activity and selectivity of **Ebio3** have been quantified through electrophysiological studies. The following tables summarize the available data.

Table 1: Inhibitory Potency of **Ebio3** on KCNQ Channels

Channel Subtype	IC50 (nM)
KCNQ2 (Kv7.2)	1.2[1][2]
KCNQ3 (Kv7.3)	15 - 196[1][2]
KCNQ4 (Kv7.4)	15 - 196[1][2]
KCNQ5 (Kv7.5)	15 - 196[1][2]
KCNQ1 (Kv7.1)	No effect

Table 2: Selectivity Profile of **Ebio3** against Other Ion Channels

Channel	Effect at 100 nM
hERG	Negligible
Kv4.2	Negligible
TREK1	Negligible
TREK2	Negligible
TASK3	Negligible
NaV1.1	Negligible
CaV3.2	Negligible
Hv1	Negligible

Data sourced from electrophysiological recordings.[1][2]

## Experimental Protocols

The pharmacological profile of **Ebio3** was elucidated using a combination of electrophysiology, structural biology, and computational modeling.

## Whole-Cell Patch-Clamp Electrophysiology

This technique was employed to measure the effect of **Ebio3** on the ion currents flowing through KCNQ2 channels expressed in a heterologous system.

Objective: To determine the inhibitory concentration (IC<sub>50</sub>) and selectivity of **Ebio3**.

Methodology:

- Cell Culture and Transfection: Human Embryonic Kidney (HEK293) cells are cultured and transiently transfected with the cDNA encoding the human KCNQ2 channel.
- Electrophysiological Recording:
  - Pipette Solution (Intracellular): Contains (in mM): 140 K-gluconate, 4 KCl, 0.5 EGTA, 10 HEPES, 4 MgATP, 0.4 NaGTP. The pH is adjusted to 7.3 with KOH.
  - Bath Solution (Extracellular): Contains (in mM): 126 NaCl, 3 KCl, 2.5 CaCl<sub>2</sub>, 1.3 MgCl<sub>2</sub>, 26 NaHCO<sub>3</sub>, 1.25 NaH<sub>2</sub>PO<sub>4</sub>, 20 glucose. The solution is bubbled with 95% O<sub>2</sub> / 5% CO<sub>2</sub>.
  - Recording: Whole-cell patch-clamp recordings are performed at room temperature. The membrane potential is held at -80 mV.
  - Voltage Protocol: KCNQ2 currents are elicited by a series of voltage steps from -90 mV to +60 mV in 10-mV increments.
- Data Analysis: The current amplitude is measured before and after the application of varying concentrations of **Ebio3**. The concentration-response curves are fitted to determine the IC<sub>50</sub> values.

Whole-Cell Patch-Clamp Workflow for Ebio3

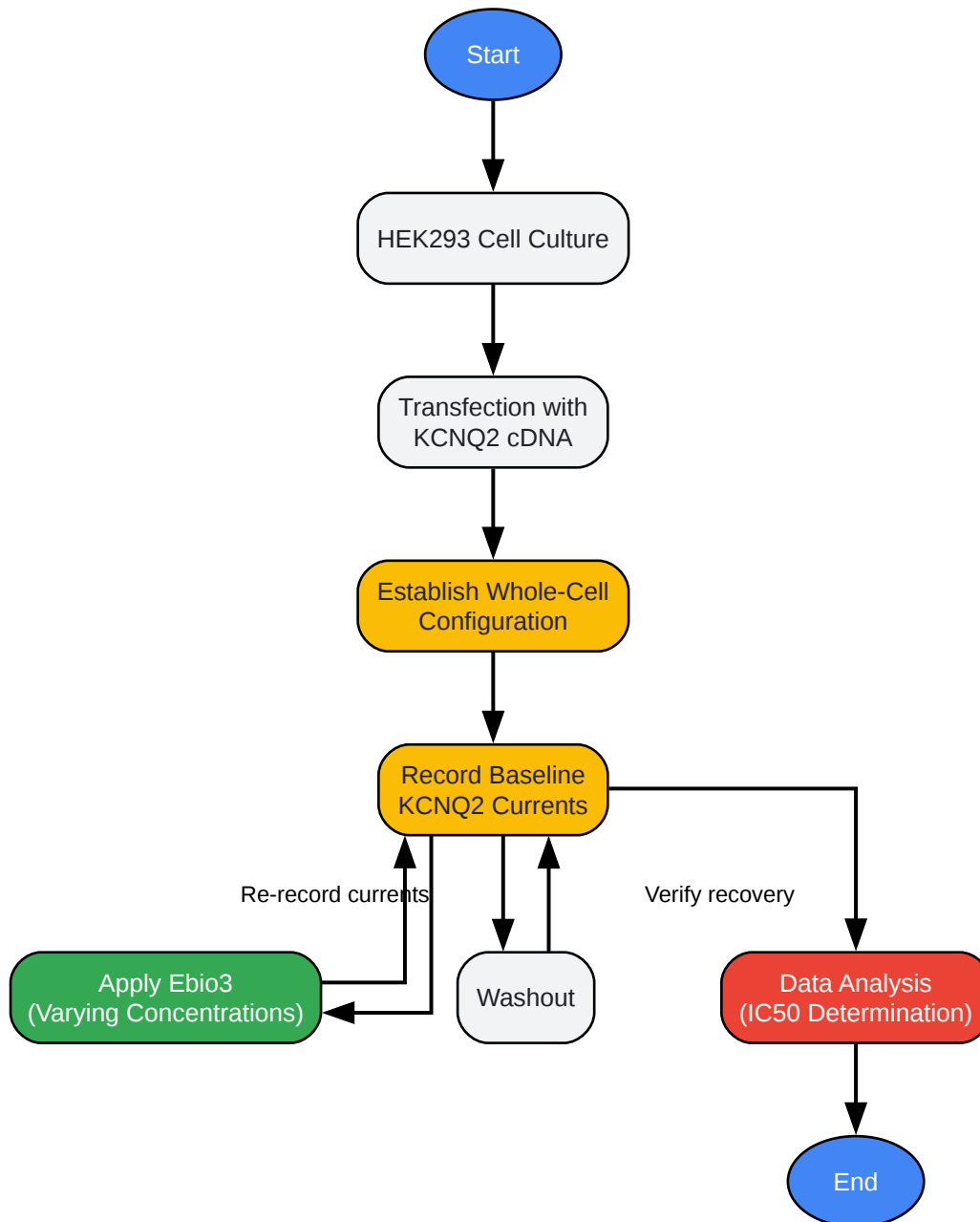

[Click to download full resolution via product page](#)

Caption: Workflow for characterizing **Ebio3** using whole-cell patch-clamp.

## Cryo-Electron Microscopy (Cryo-EM)

Cryo-EM was used to determine the high-resolution structure of the KCNQ2 channel in complex with **Ebio3**, providing insights into its binding site and mechanism of action.

Objective: To visualize the binding pose of **Ebio3** on the KCNQ2 channel.

Methodology:

- **Protein Expression and Purification:** The human KCNQ2 channel is expressed in a suitable system (e.g., HEK293 cells) and purified.
- **Complex Formation:** Purified KCNQ2 is incubated with a saturating concentration of **Ebio3**.
- **Sample Preparation:** The KCNQ2-**Ebio3** complex is applied to a cryo-EM grid, blotted, and plunge-frozen in liquid ethane to create a thin layer of vitreous ice.
- **Data Collection:** The frozen grids are imaged using a transmission electron microscope equipped with a direct electron detector. A large dataset of particle images is collected.
- **Image Processing and 3D Reconstruction:** The particle images are processed to generate a high-resolution 3D reconstruction of the KCNQ2-**Ebio3** complex.

## Molecular Dynamics (MD) Simulations

MD simulations were performed to investigate the dynamic interactions between **Ebio3** and the KCNQ2 channel and to understand the conformational changes that lead to channel inactivation.

Objective: To model the dynamic interactions and conformational changes of the KCNQ2-**Ebio3** complex.

Methodology:

- **System Setup:** The cryo-EM structure of the KCNQ2-**Ebio3** complex is used as the starting point. The complex is embedded in a model lipid bilayer and solvated with water and ions to mimic a physiological environment.

- Force Field Parametrization: A suitable force field (e.g., CHARMM36 for protein and lipids, CGenFF for the small molecule) is used to describe the atomic interactions.
- Equilibration: The system undergoes a series of energy minimization and equilibration steps to relax any steric clashes and to reach a stable temperature and pressure.
- Production Simulation: A long-timescale MD simulation (nanoseconds to microseconds) is run to sample the conformational landscape of the complex.
- Trajectory Analysis: The simulation trajectory is analyzed to study the stability of **Ebio3** binding, the nature of its interactions with KCNQ2 residues, and the resulting structural changes in the channel.

## Molecular Dynamics Simulation Workflow

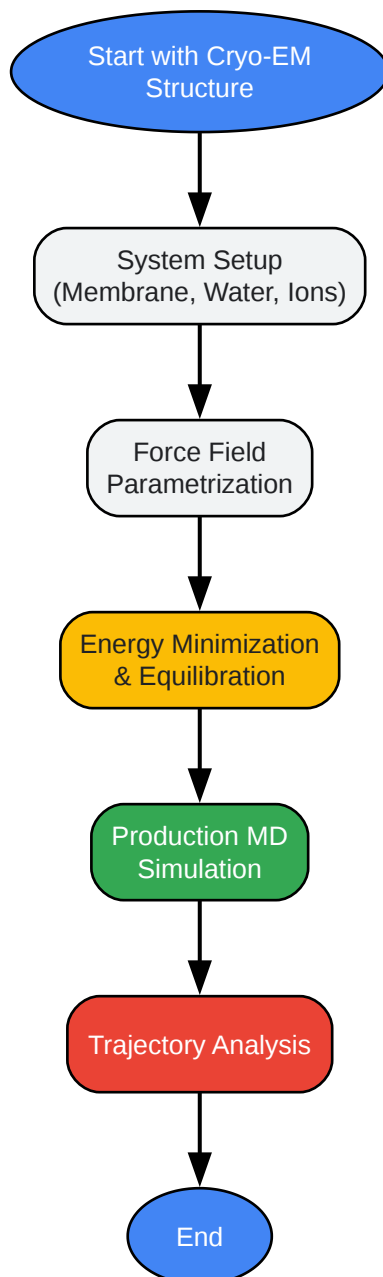

[Click to download full resolution via product page](#)



### Need Custom Synthesis?

BenchChem offers custom synthesis for rare earth carbides and specific isotopic labeling.

Email: [info@benchchem.com](mailto:info@benchchem.com) or [Request Quote Online](#).

## References

- 1. EMDB < EMD-30445 [ebi.ac.uk]
- 2. Whole Cell Patch Clamp Protocol | AXOL Bioscience [axolbio.com]
- To cite this document: BenchChem. [The Pharmacological Profile of Ebio3: A Technical Guide]. BenchChem, [2025]. [Online PDF]. Available at: [https://www.benchchem.com/product/b15584473#exploring-the-pharmacological-profile-of-ebio3]

### Disclaimer & Data Validity:

The information provided in this document is for Research Use Only (RUO) and is strictly not intended for diagnostic or therapeutic procedures. While BenchChem strives to provide accurate protocols, we make no warranties, express or implied, regarding the fitness of this product for every specific experimental setup.

**Technical Support:** The protocols provided are for reference purposes. Unsure if this reagent suits your experiment? [[Contact our Ph.D. Support Team for a compatibility check](#)]

**Need Industrial/Bulk Grade?** [Request Custom Synthesis Quote](#)

## BenchChem

Our mission is to be the trusted global source of essential and advanced chemicals, empowering scientists and researchers to drive progress in science and industry.

### Contact

Address: 3281 E Guasti Rd

Ontario, CA 91761, United States

Phone: (601) 213-4426

Email: [info@benchchem.com](mailto:info@benchchem.com)